

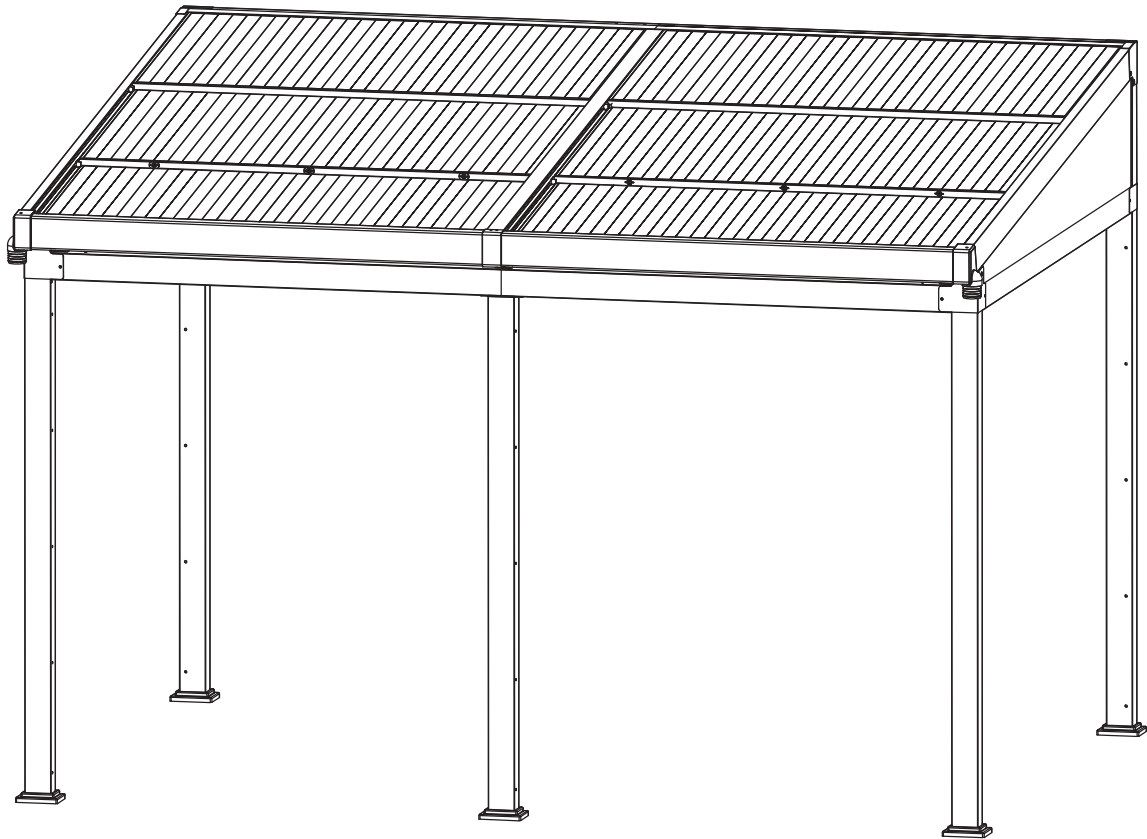

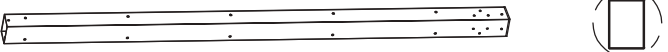







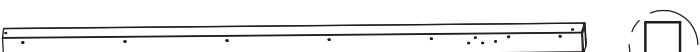
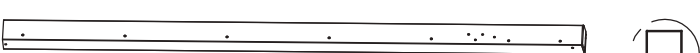

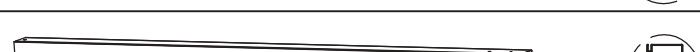
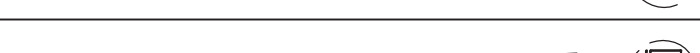
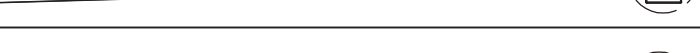
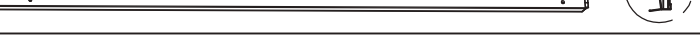
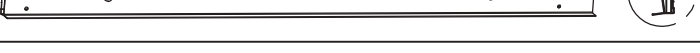



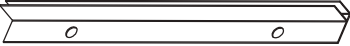
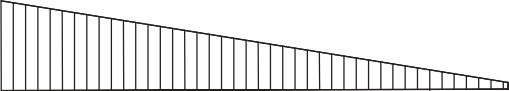

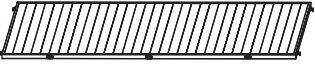

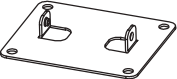



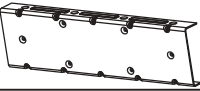

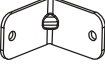



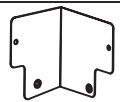







GFA30780A

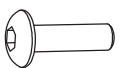
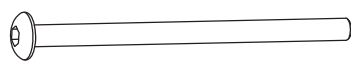
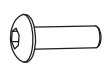

REF	PCE	PIECE	QTY	DIM
	A1		1	
	A2		1	
	A3		1	
	A4		1	
	A5		1	
	B1		1	
	B2		1	
	B3		2	
	B4		1	
	B5		1	
	C1		1	
	C2		1	
	C3		1	
	D1		1	
	D2		1	

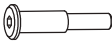
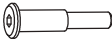
REF	PCE	PIECE	QTY	DIM
	E	 (F)	2	
	F1		1	
	F2		1	
	G1		2	
	G2		2	
	G3		2	
	K1		5	
	K2		5	
	L1		6	
	L2		1	
	L3		1	
	L4		1	
	M1		6	
	M3		1	
	N1		1	

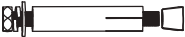
REF	PCE	PIECE	QTY	DIM
	N2		1	
	N3		2	
	N4		1	
	N5		1	
	O1		1	
	O2		1	
	O3		1	
	P		6	
	Q		8	
	R		1	
	U		1	
	V	 M8	18	
	W1	 M8*20	42	
	W2	 M8*150	2	
	W3	 M6*15	84	

REF	PCE		QTY	DIM
	W4		2	M6*10
	X1		4	Ø8.8*20*M6*12
	X3		2	Ø7.5*20*M6*12
	X4		2	Ø7.5*M6*40
	Y		10	
	Z1		2	
	Z2		2	

STEP 01

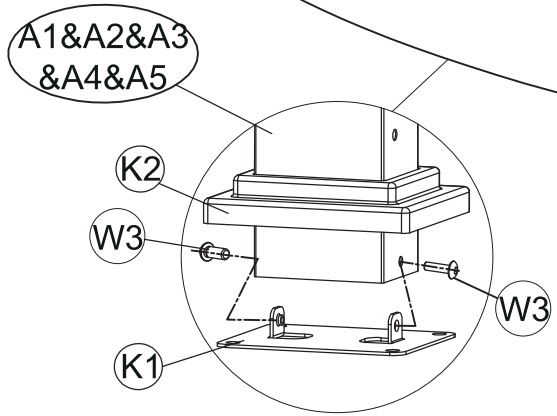
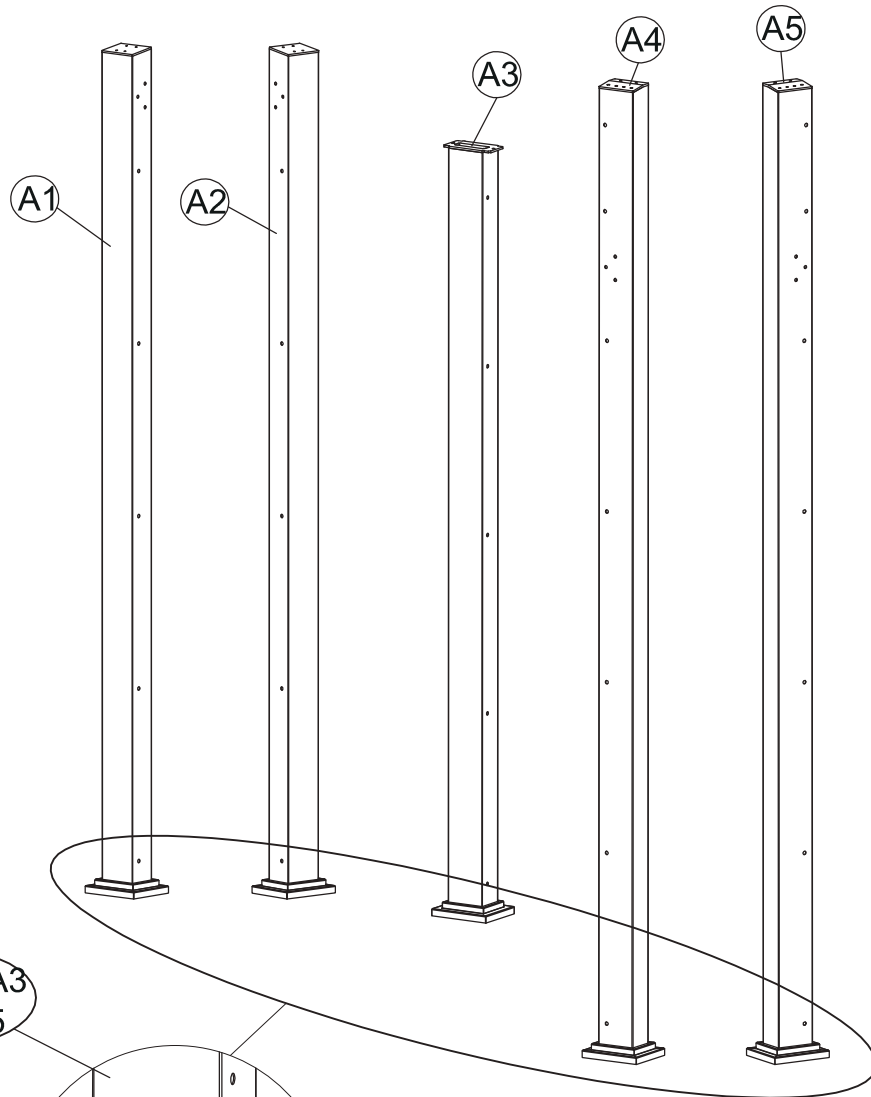

	A1(X1)		K1(X5)
	A2(X1)		K2(X5)
	A3(X1)		W3 (X10)
	A4(X1)		
	A5(X1)		

STEP 02

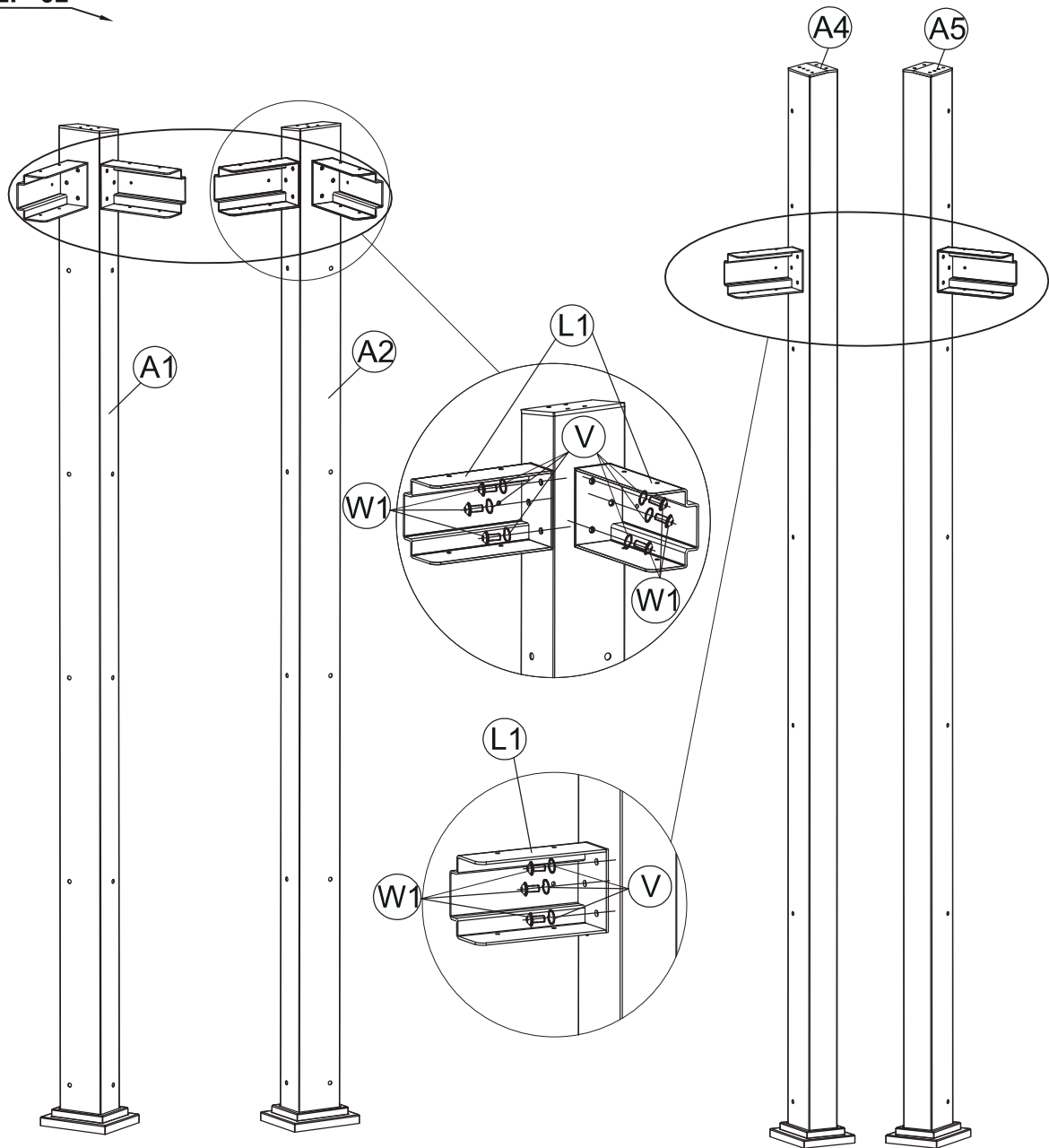

	L1 (X6)		M8*20 W1 (X18)
			M8 V (X18)

STEP 03

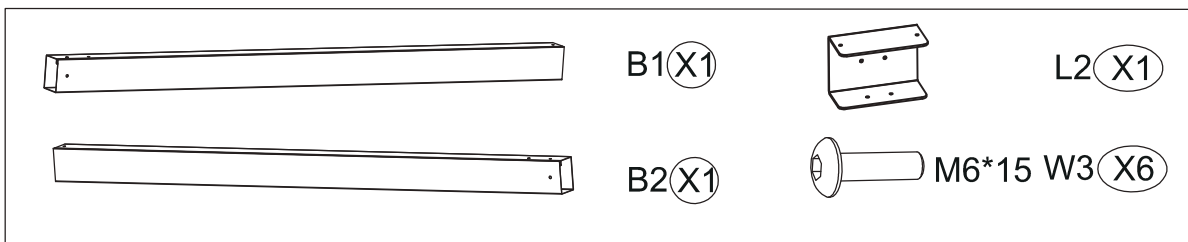
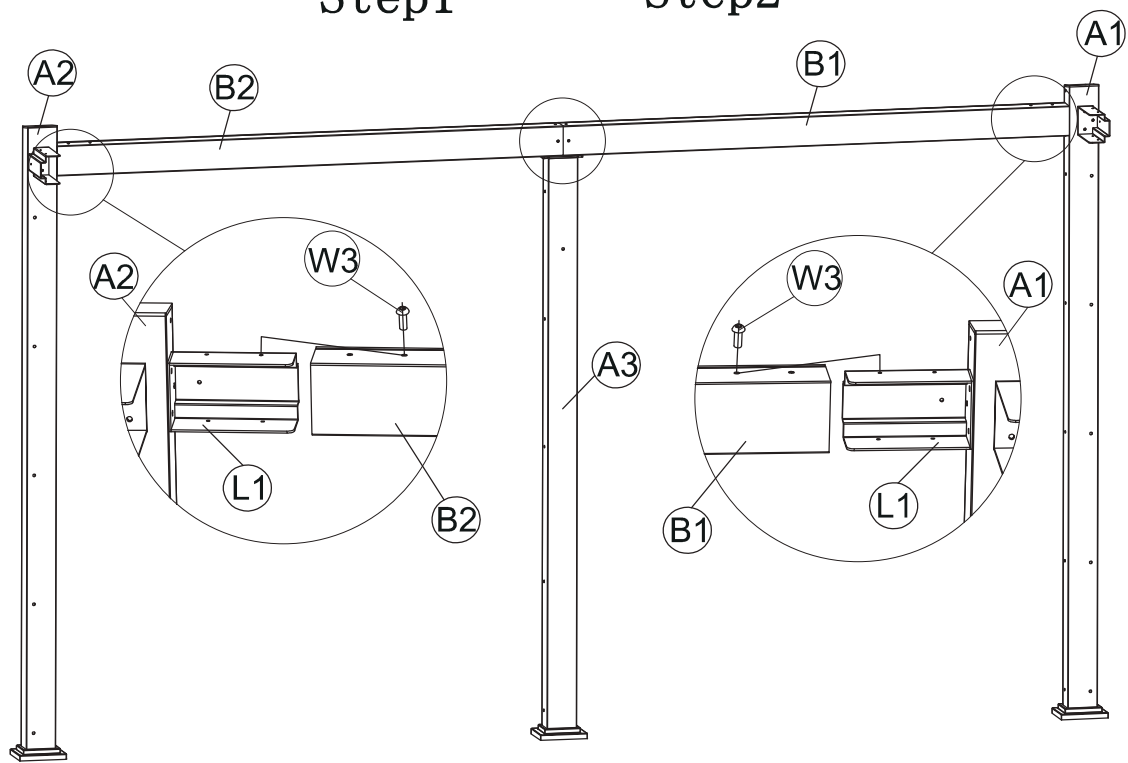
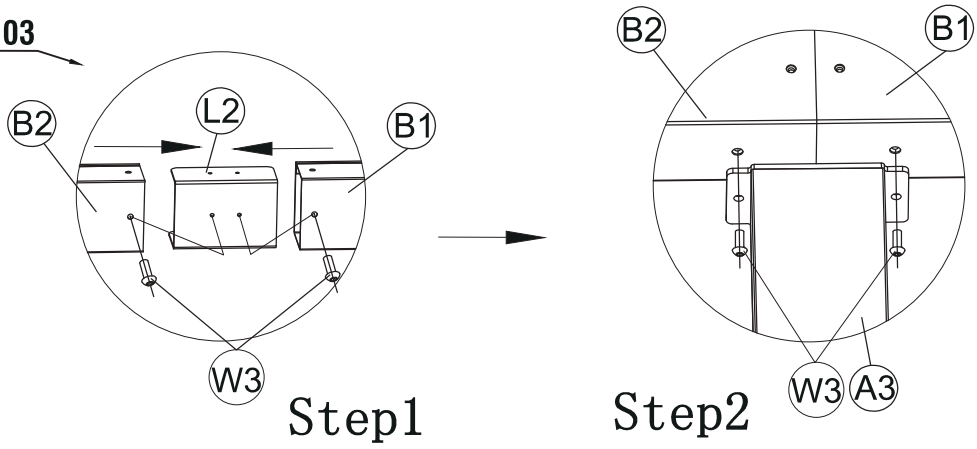

STEP 04

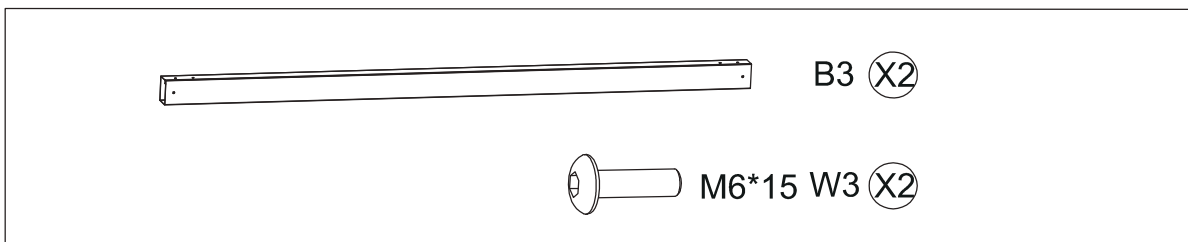
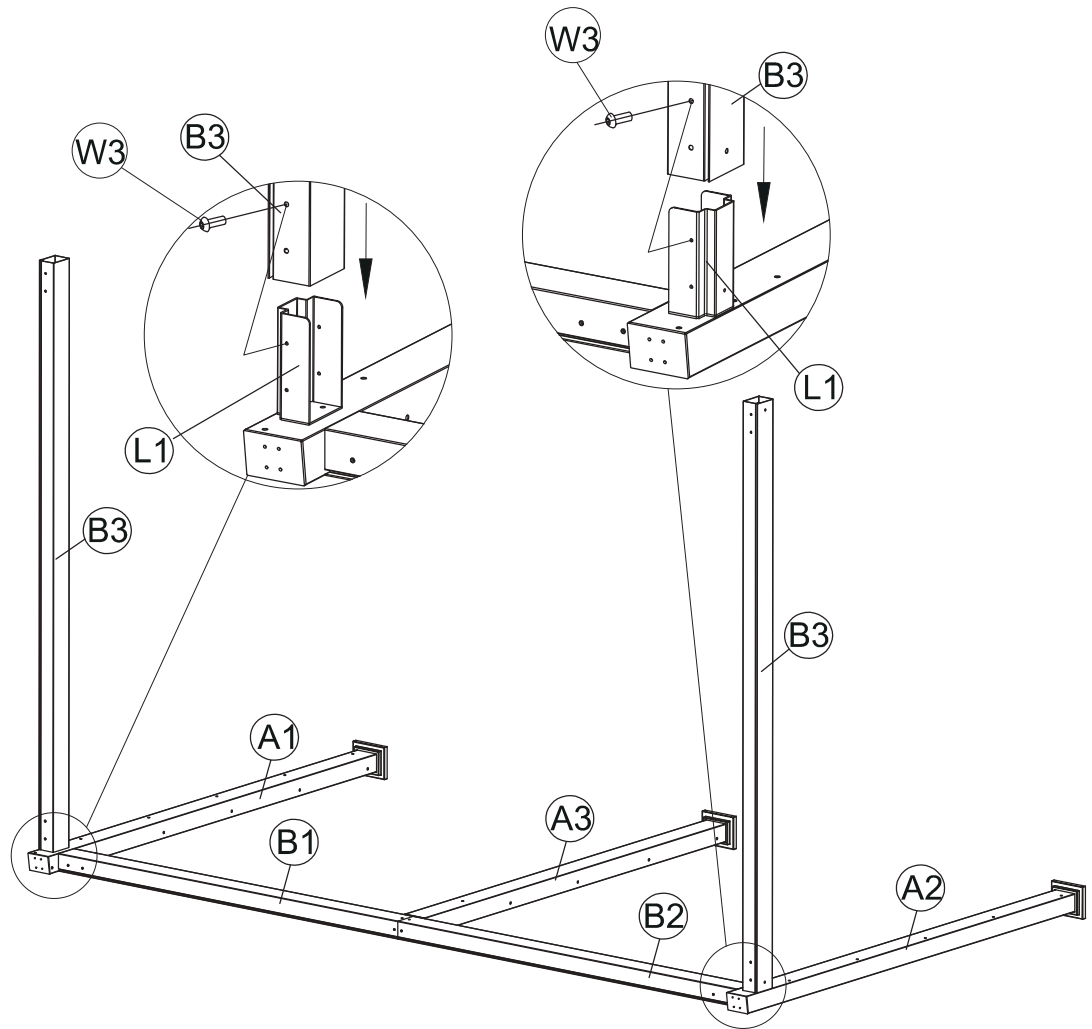

STEP 05

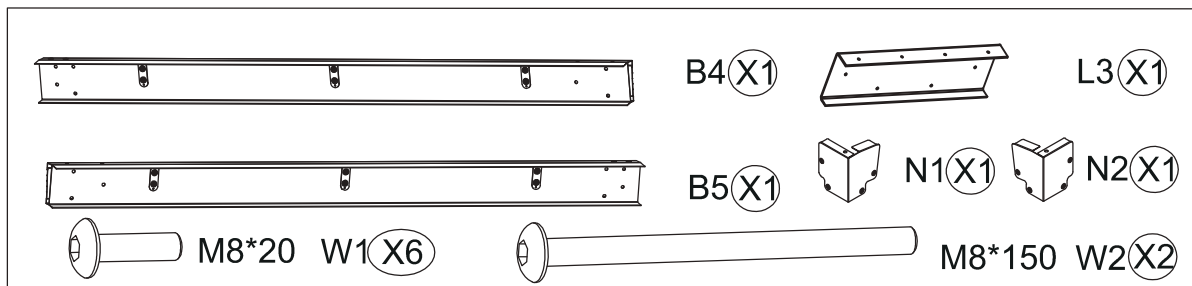
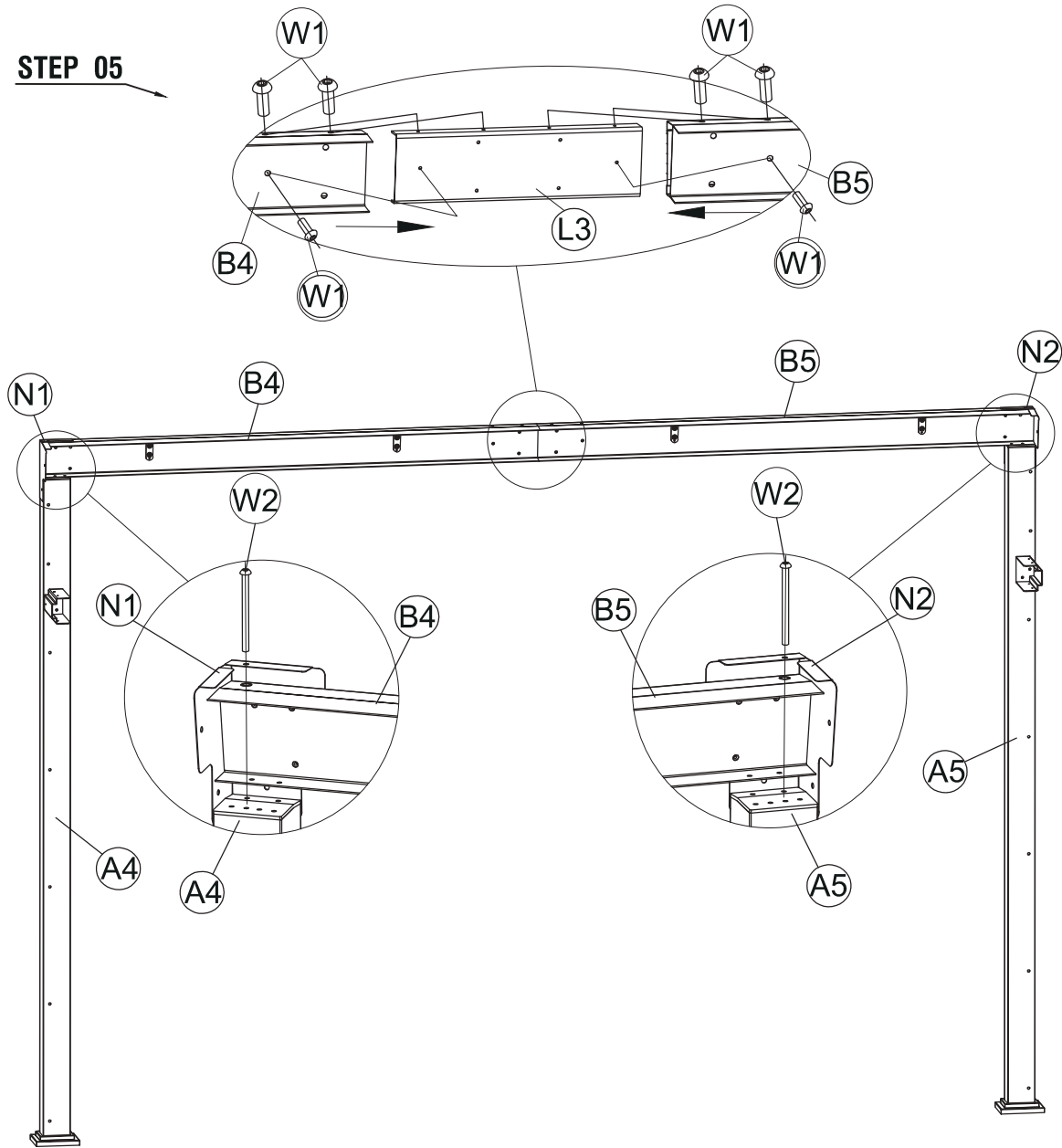

STEP 06

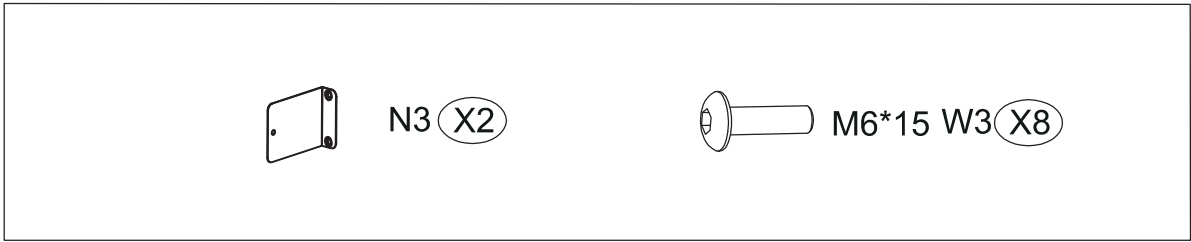
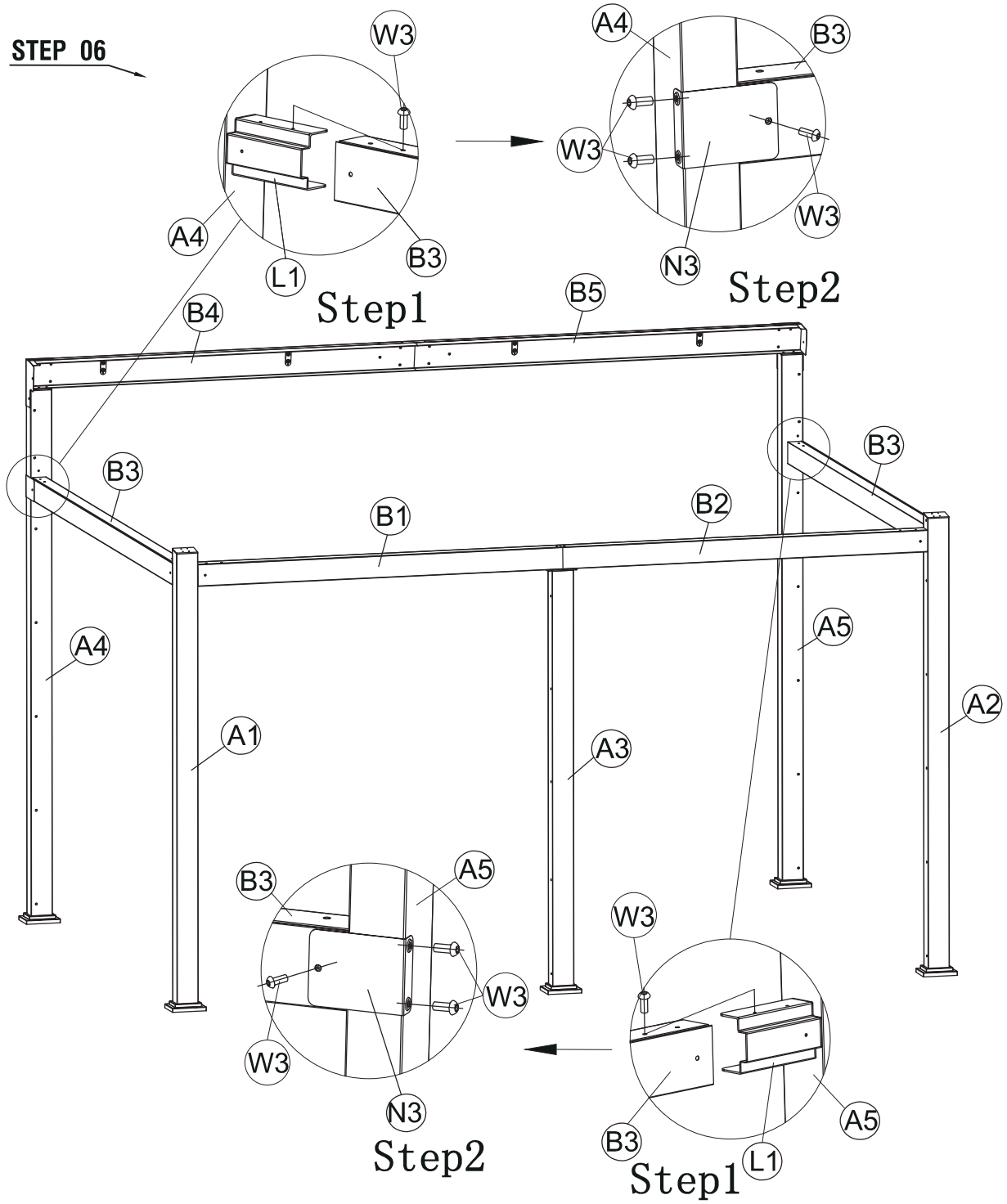

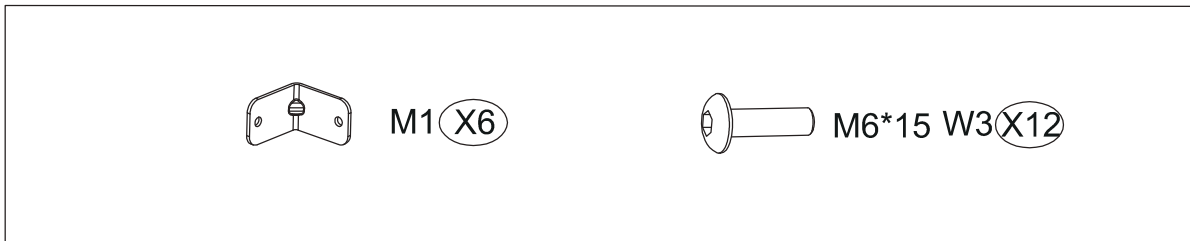
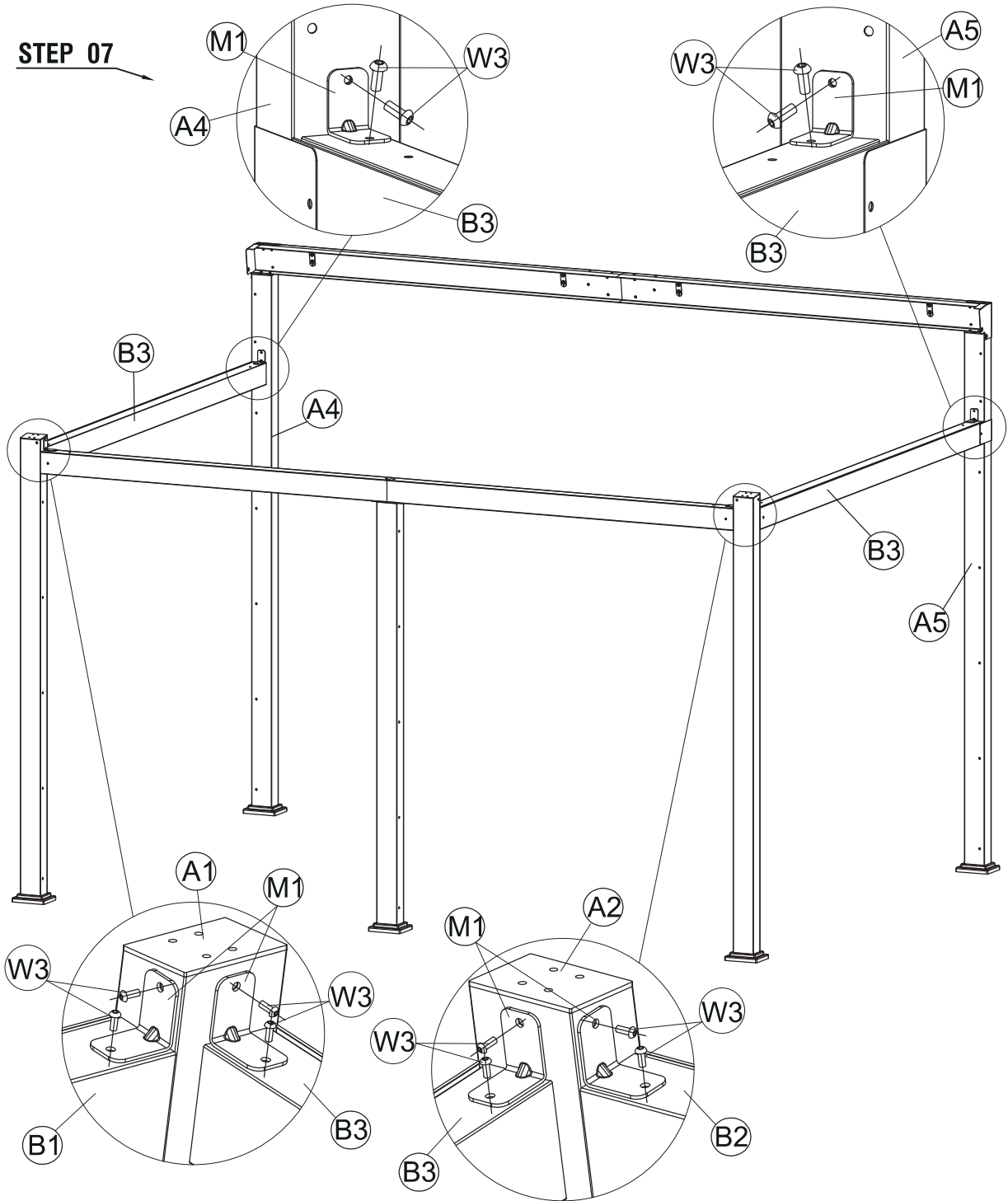

STEP 07

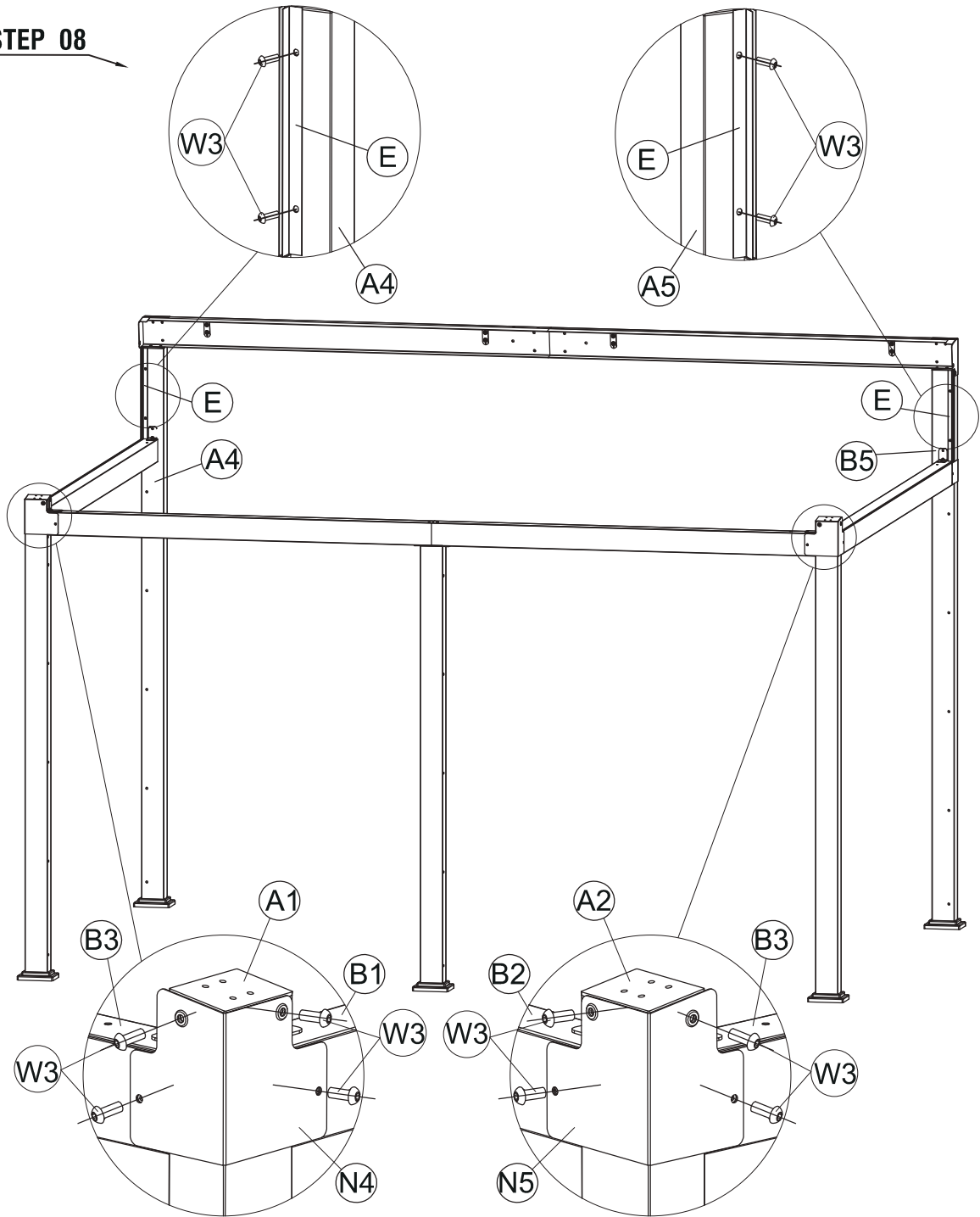

STEP 08

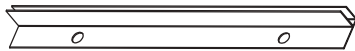
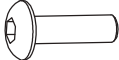

	E (X2)	 M6*15 W3 (X12)
 N4 (X1)	 N5 (X1)	

STEP 09

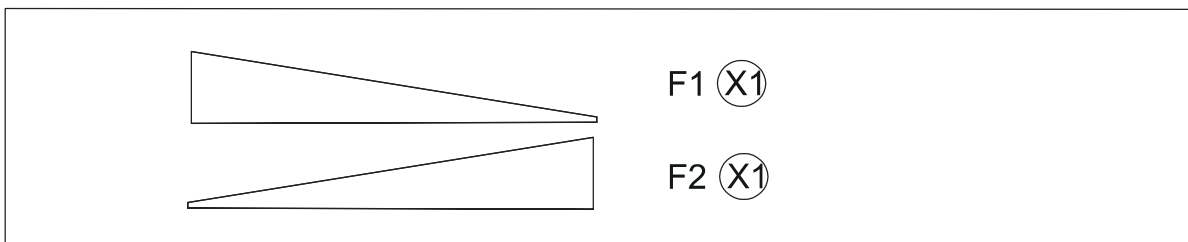
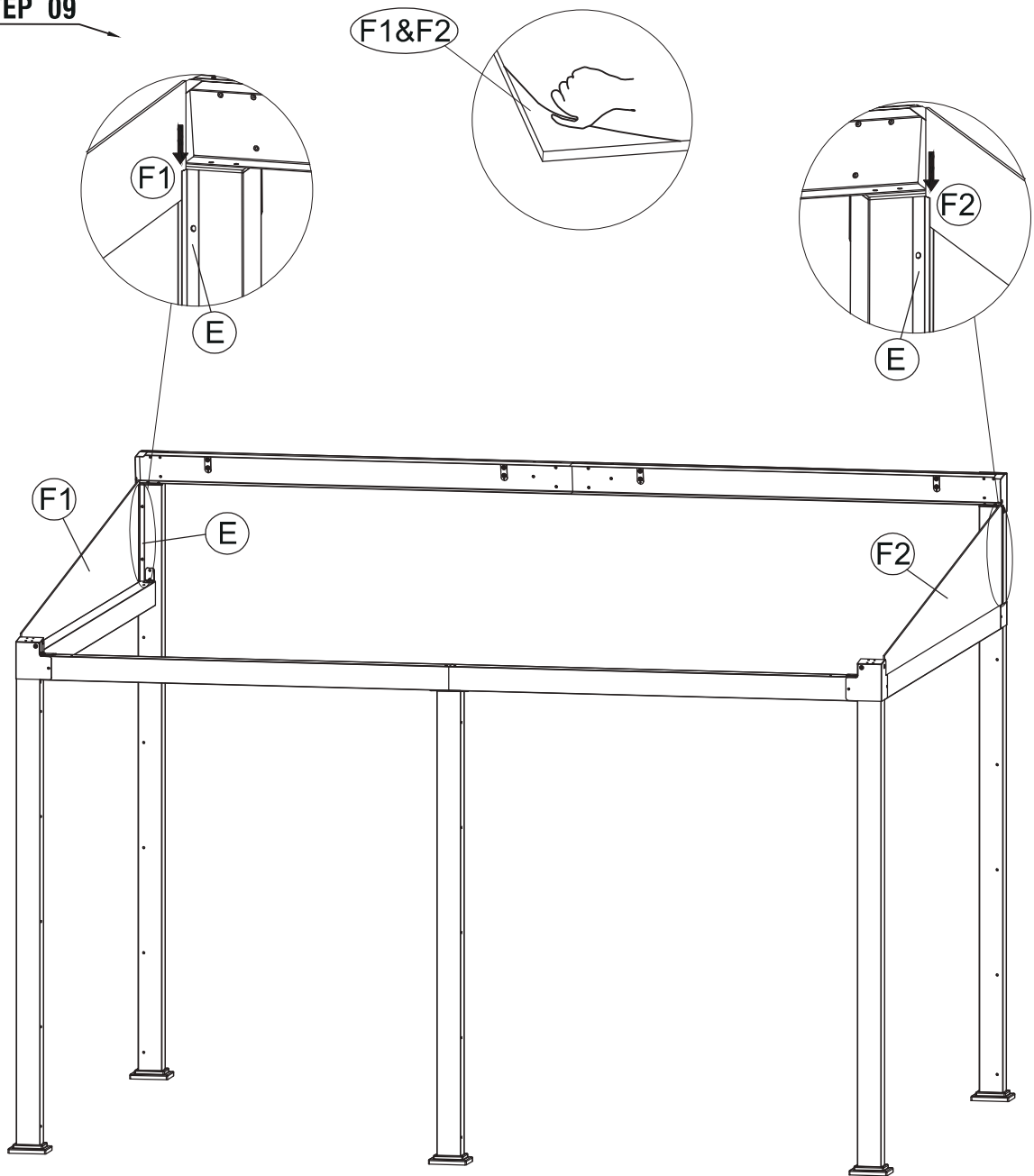

STEP 10

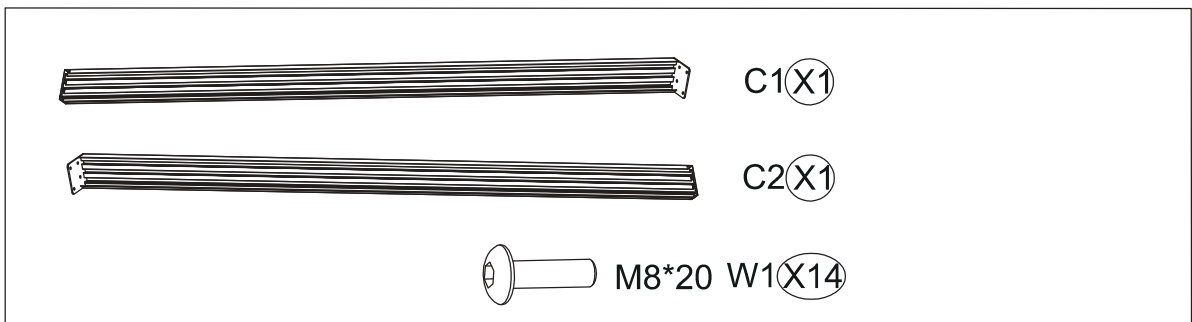
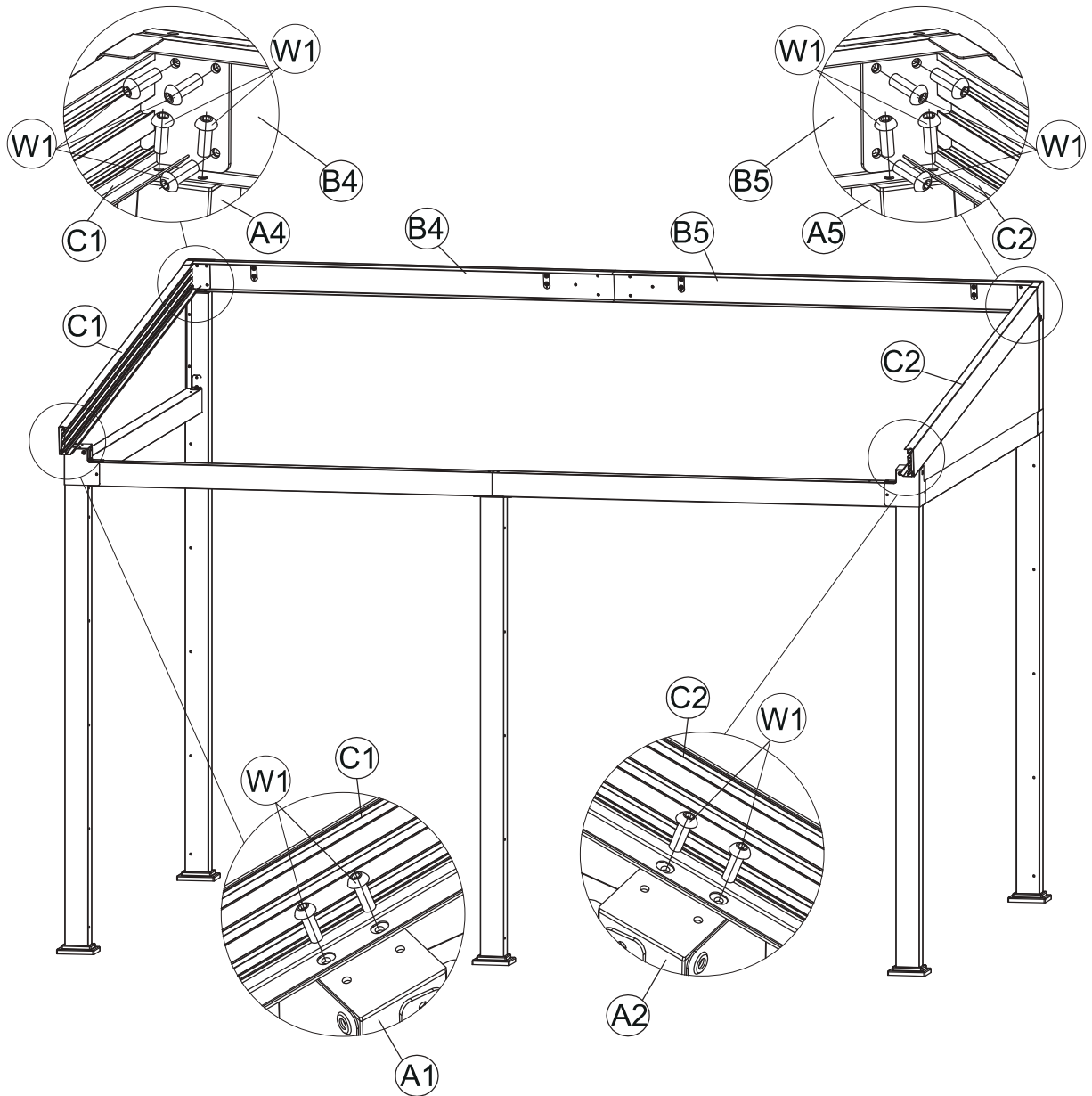

STEP 11

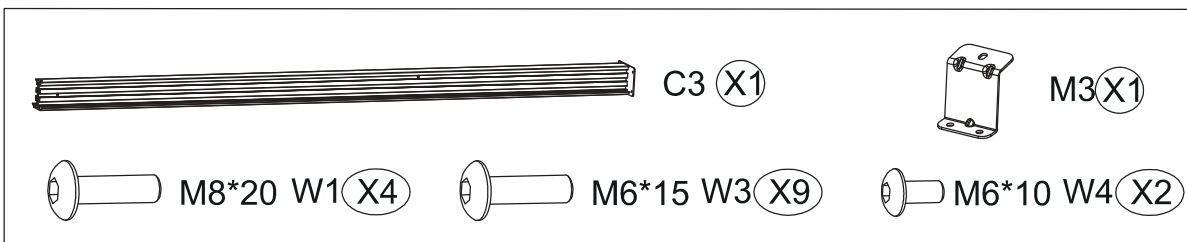
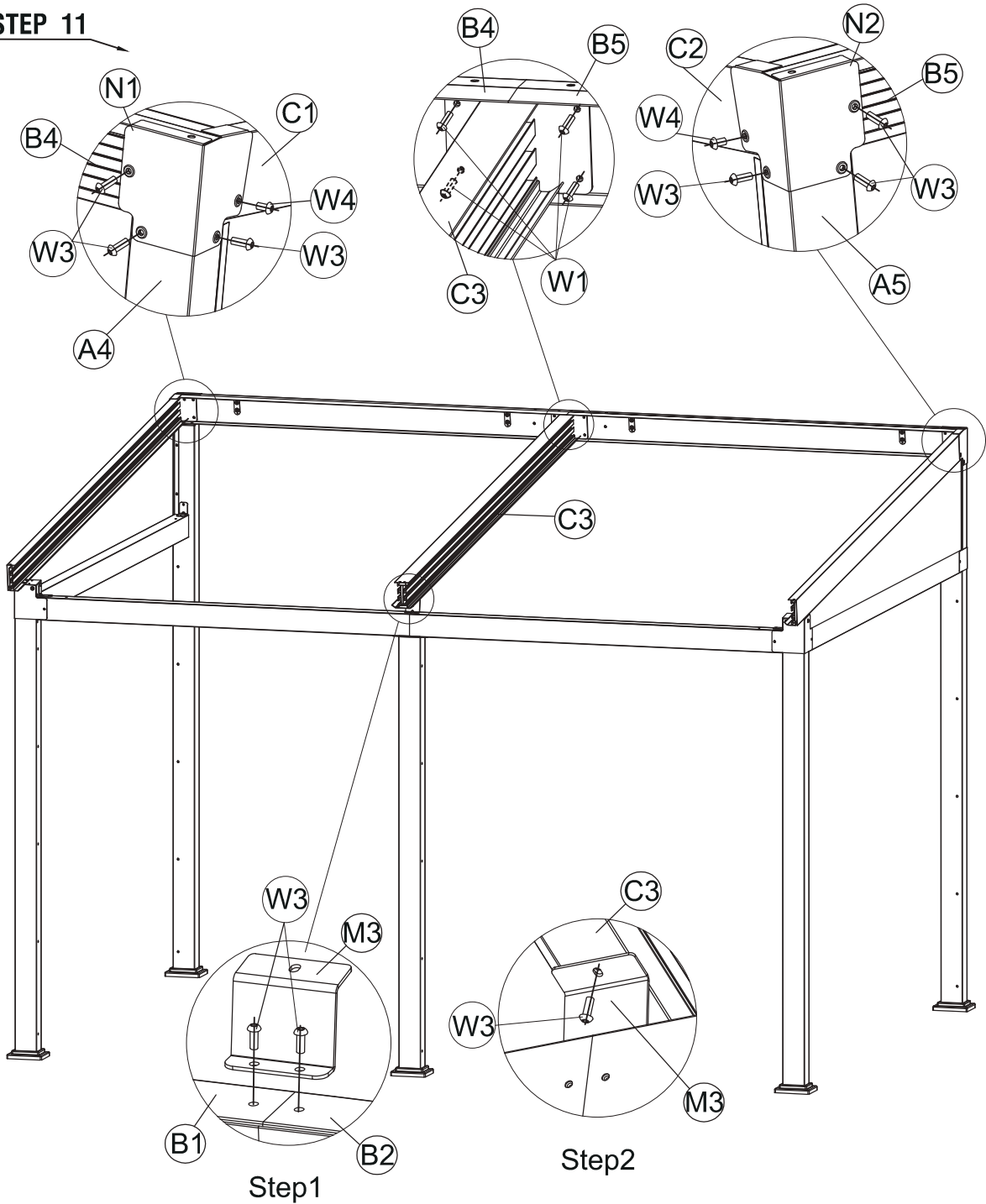

STEP 12

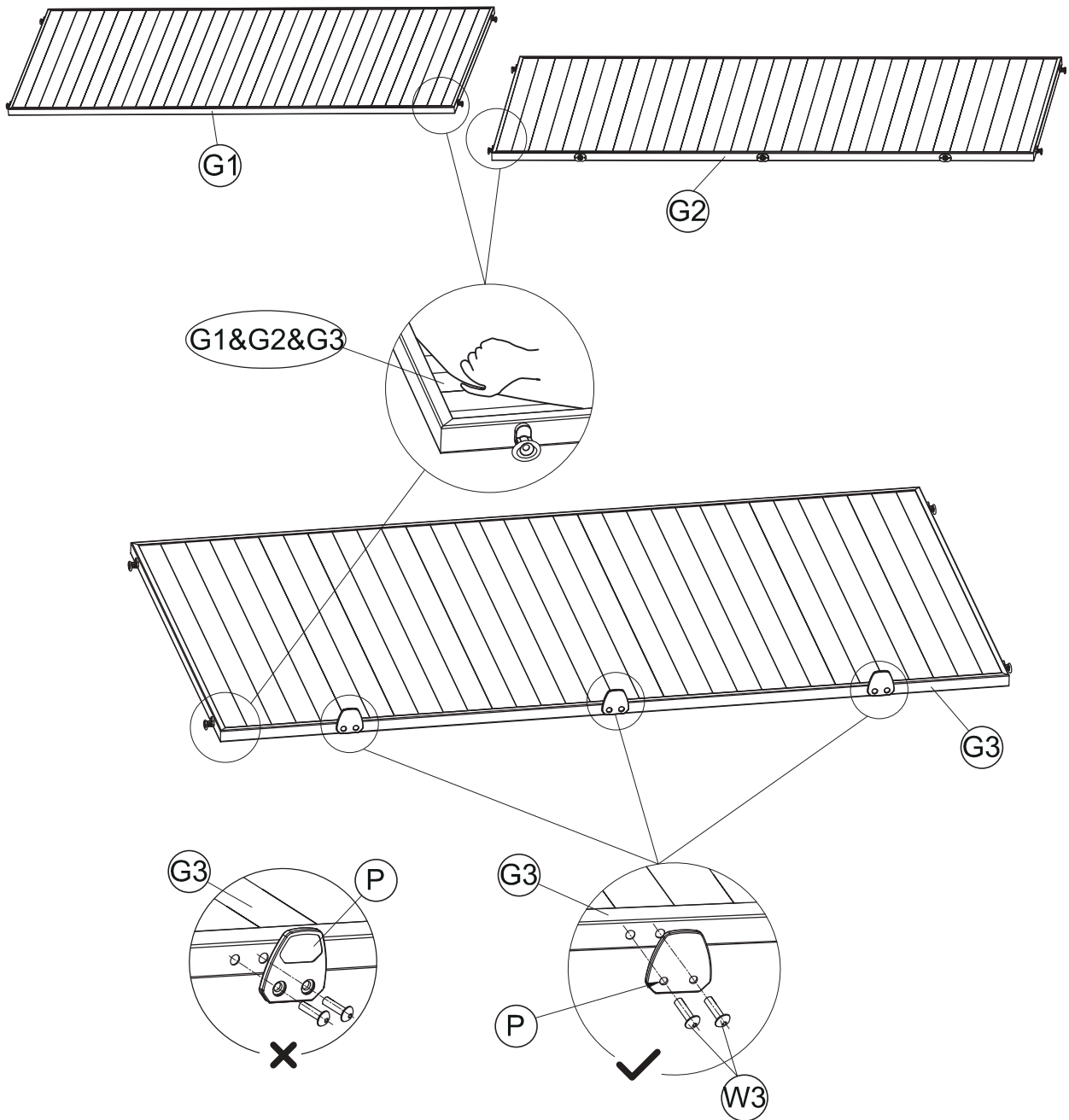

	G1 X2		G2 X2
	G3 X2		P X6
			M6*15 W3 X12

STEP 13

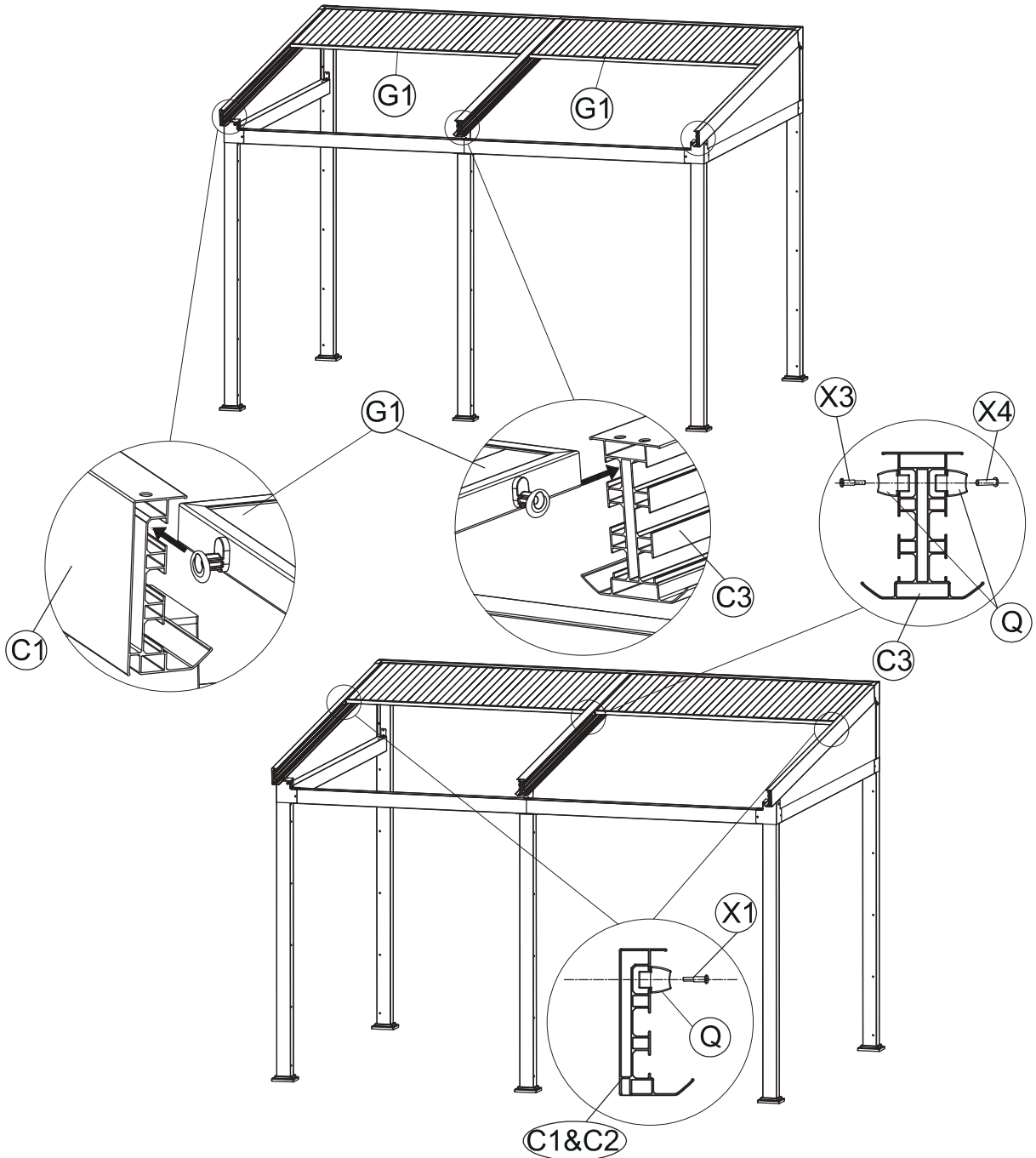

	Q X4		Ø8.8*20*M6*12 X1 X2
	Ø7.5*20*M6*12 X3 X1		Ø7.5*M6*40 X4 X1

STEP 14

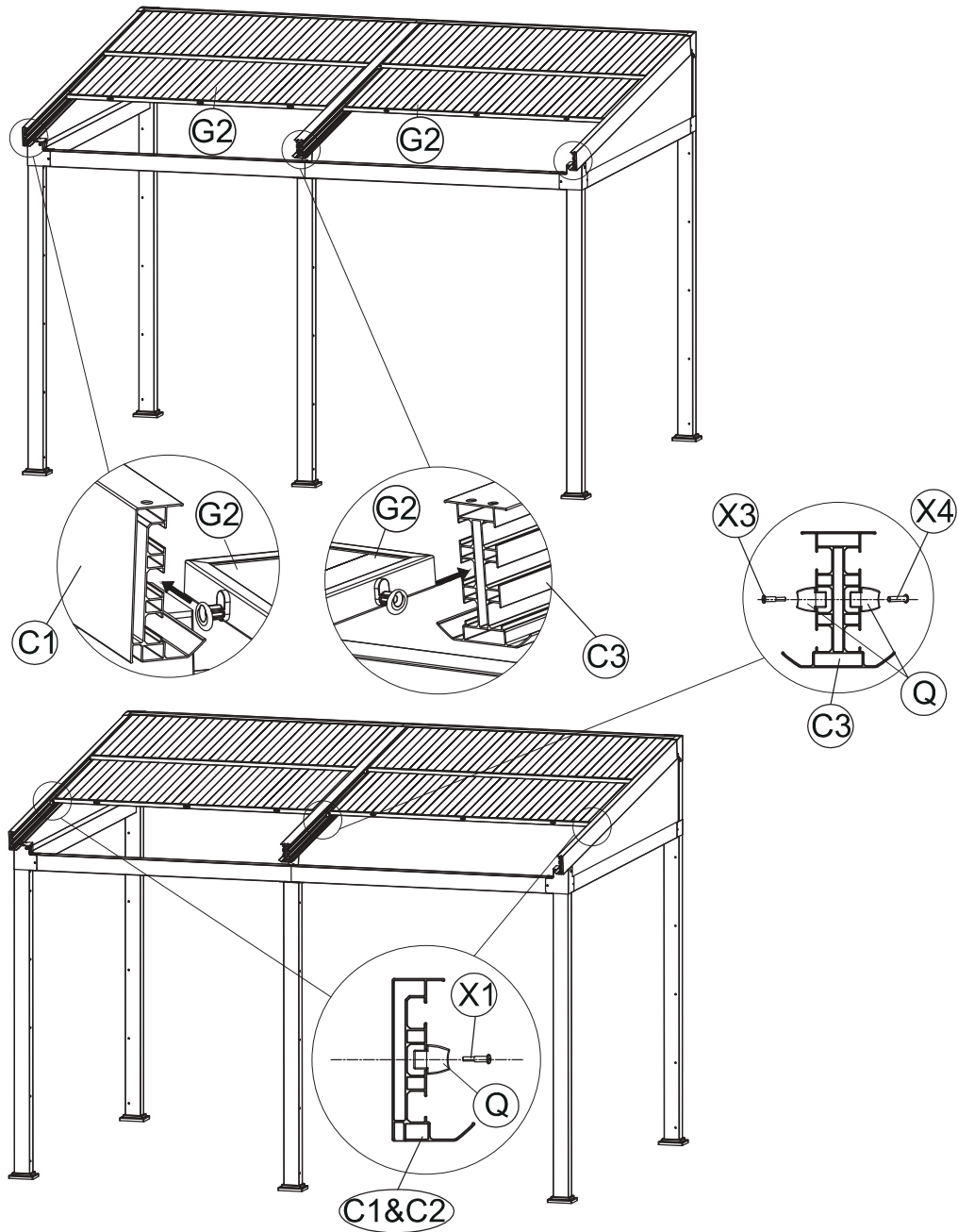

	Q (X4)		Ø8.8*20*M6*12	X1 (X2)	
	Ø7.5*20*M6*12	X3 (X1)		Ø7.5*M6*40	X4 (X1)

STEP 15

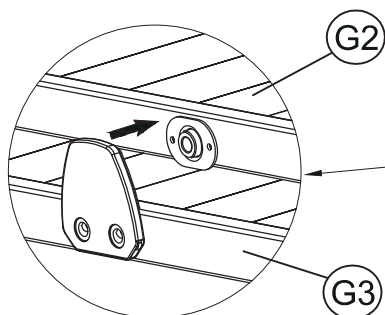
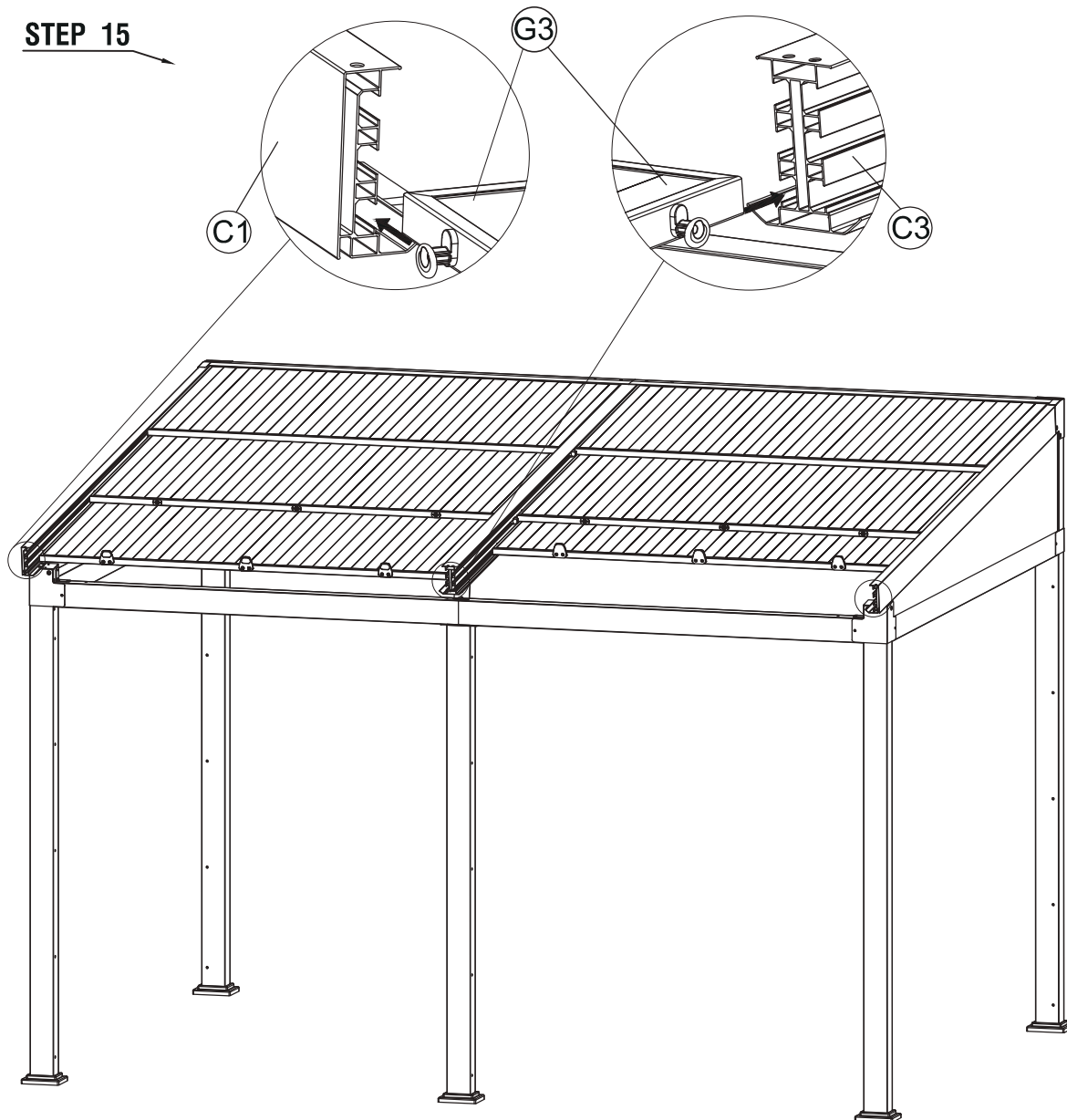

Um ein Verrutschen zu verhindern, muss das Dachelement G3 auf das Dachelement G2 geschoben werden, damit sich das ovale Eisenblech von Dachelement G3 (siehe Abbildung), mit dem Magneten von Dachelement G2 verbinden werden kann.

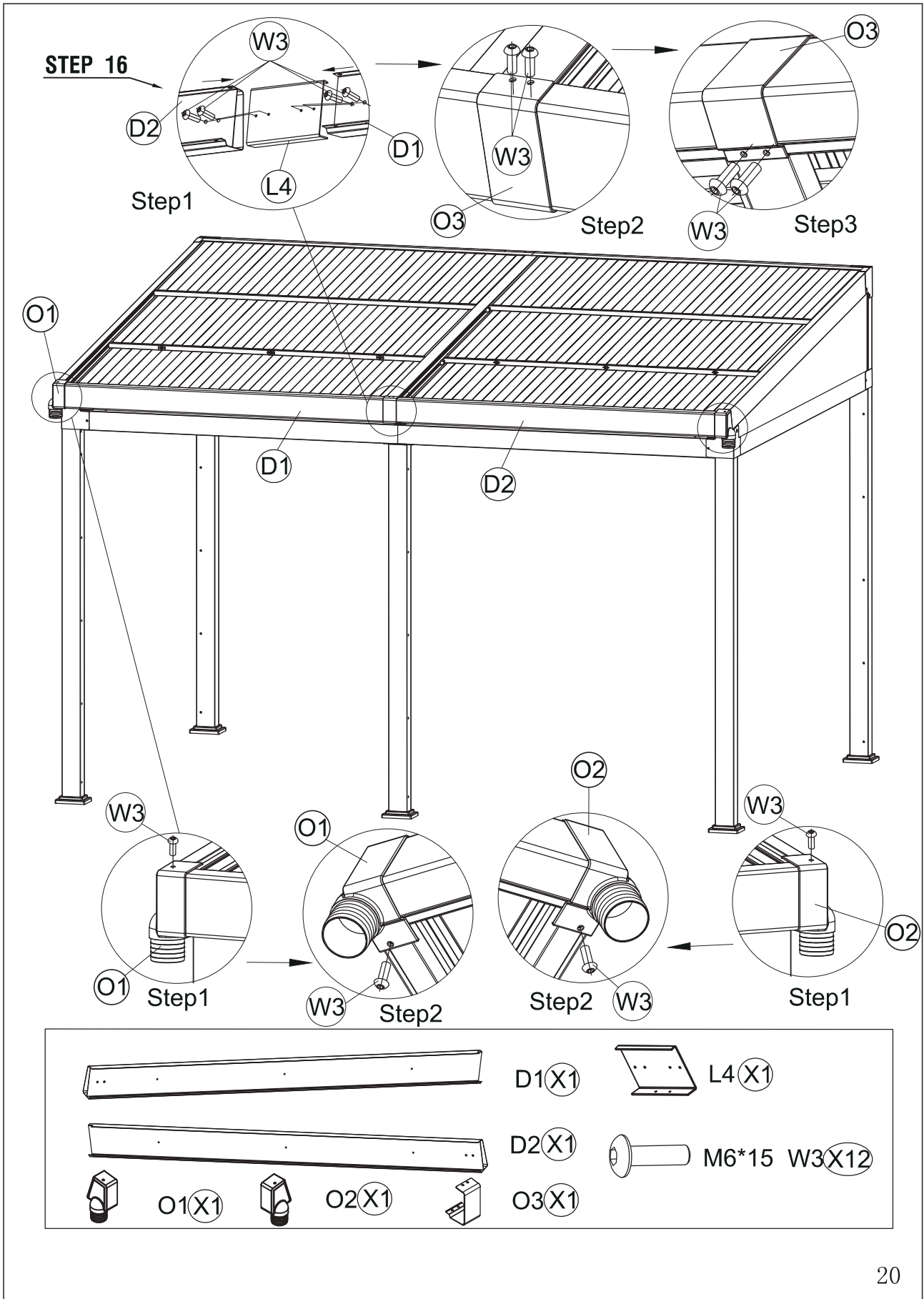

STEP 17

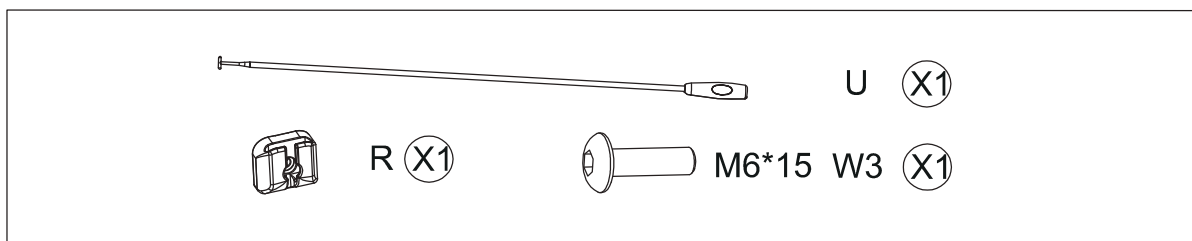
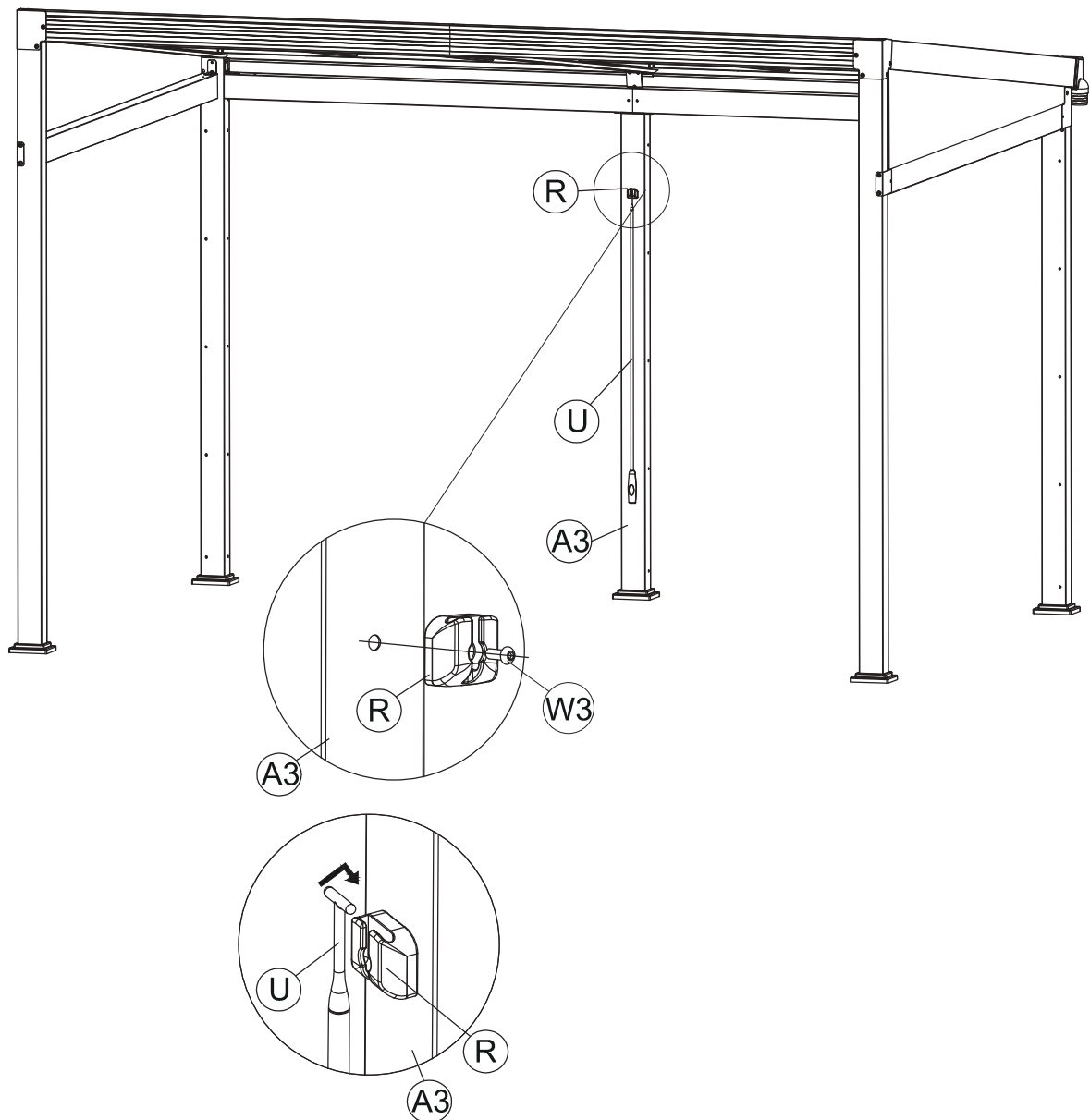

STEP 18

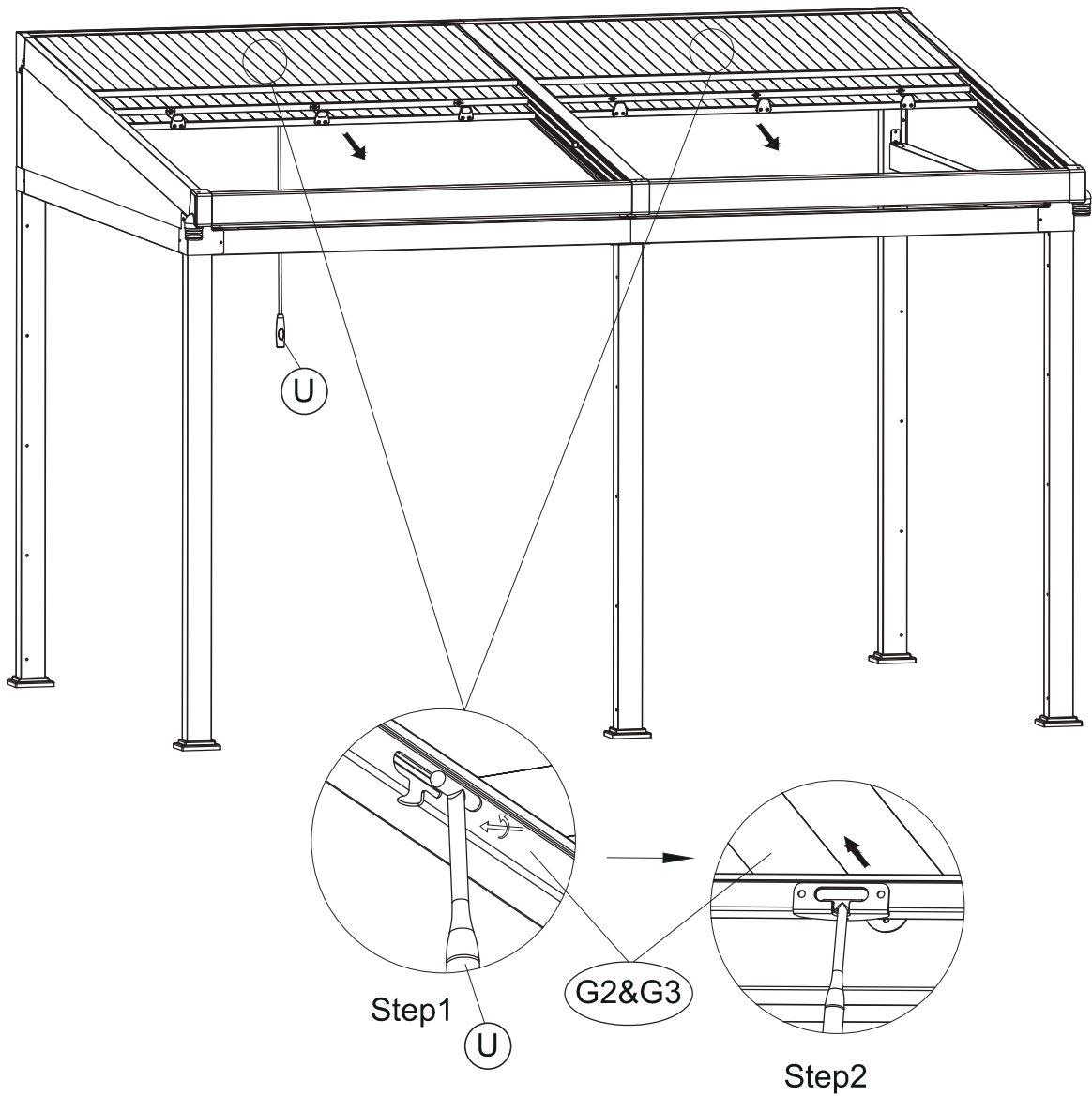

STEP 19

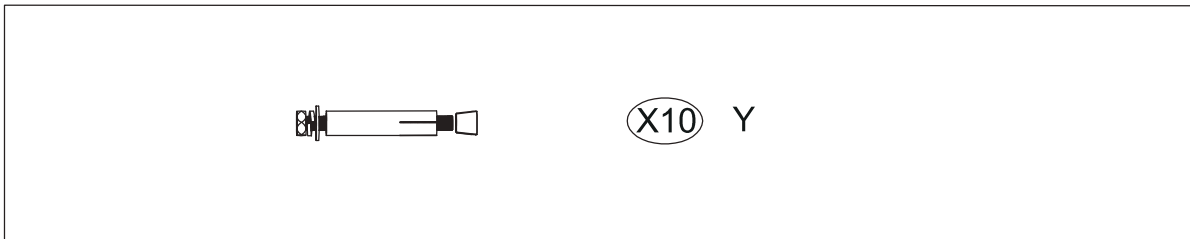
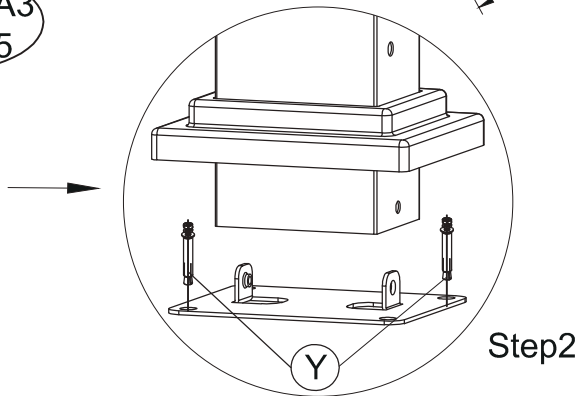
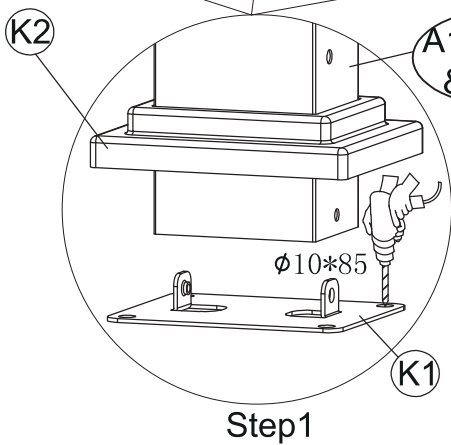
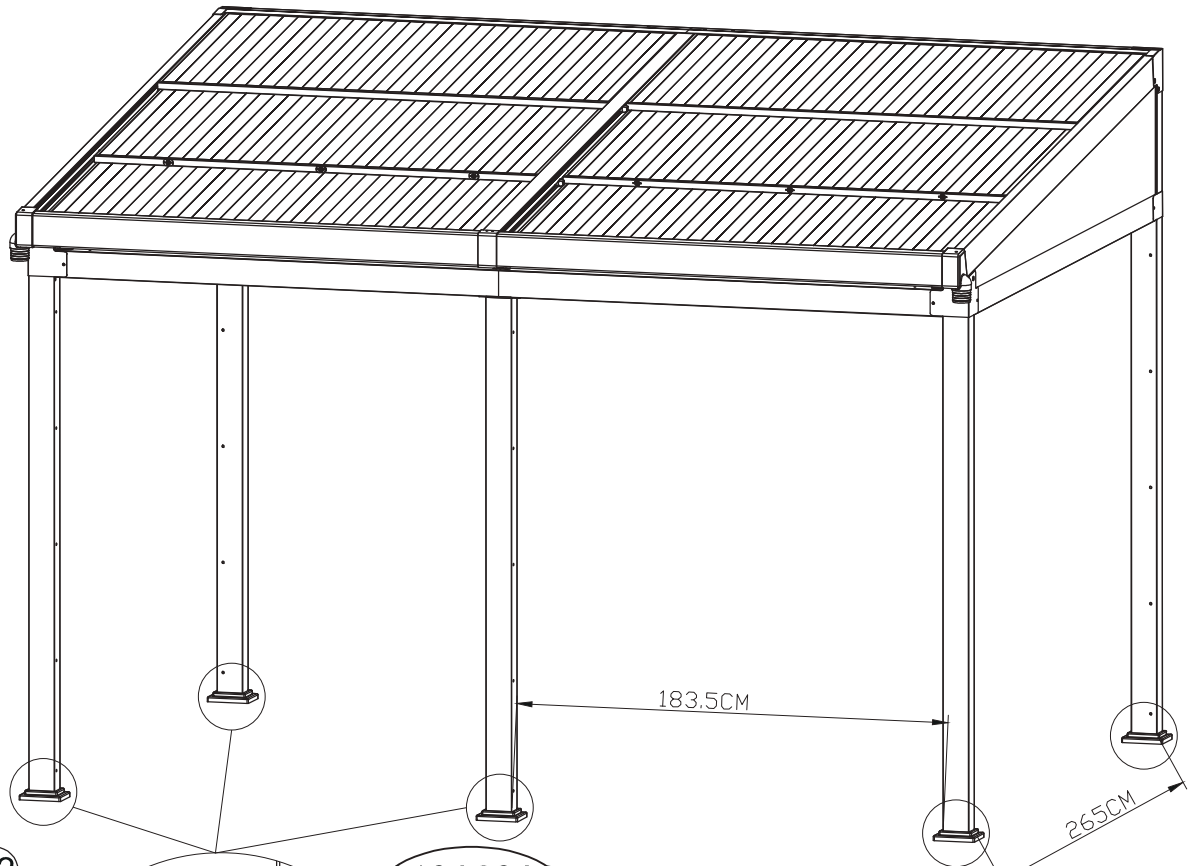

IBIZZA CABRIO PAVILLON 3X4M POLYDACH

General Safety Instructions

1. Please refer to the instruction manual and ensure all parts are within the box before you begin assembling.
2. Please keep children and animals away from the assembly site, also sources of possible ignition should be avoided when assembling.
3. Please comply with basic safety precaution requirements during assembling to reduce the risk of personal injury and damage to the product. (Recommended to use gloves, goggles, non-slip shoes, etc.)
4. Please allow sufficient time to assemble the product, to avoid having semi-assembled parts of the product. (Assembling requires at least 4 persons and minimum two hours)
5. Please assemble the product on the flat ground, ensure all screws are tightened before using. We suggest to use protection against scratching from the ground during assembling (cover the ground with cardboard or cloth)
6. Please do not lean ladders at the product when assembling or when you want to clean the roof. Climbing and standing at the top of the product (roof) is prohibited.

Assembly instruction

1. The roof board with thin foam on the surface must face to the sun. Before assembling, do not tear off it.
2. Do not place any thermal conductor in or under the product.
(Oven or heater)
3. The product can be used all year round. Maximum load of the whole gazebo is 300kg. When it snows for a long time, you need to clean the snow from time to time. If there is extreme weather conditions (such as heavy snowfall and/or hail), please remove the roof board and store it inside

Care instructions

1. Regular cleaning of the drains is recommended. Remove leaves and other dirt to keep the drainage pipes clean.
2. Timely clean the dirt on the frame, Please soak a soft cloth or foam in neutral detergent , then wash them with water.
3. If necessary, pull roof board out and clean the dirt outside and inside the roof port.
4. Please check the screws and making sure they are tight after using the product for some time. It is recommended once every quarter).

Allgemeine Sicherheitshinweise

1. Bitte lesen Sie die Aufbau- und Bedienungsanleitung aufmerksam durch und heben diese sorgfältig auf um später nachlesen zu können.

Stellen Sie bitte sicher das alle aufgeführten Teile vorhanden sind bevor Sie mit dem Aufbau beginnenn.

2. Kinder und Haustiere sollten während des Aufbaus ferngehalten werden.

3. Bitte benützen Sie einfache Sicherheitsstandards um mögliche Verletzungen zu vermeiden (Arbeitshandschuhe, rutschfeste Schuhe) und um Beschädigungen am Produkt selber vorzubeugen.

4. Planen Sie bitte genügend Zeit für den Aufbau des Pavillion ein.

Wir schlagen vor, den Pavillion mit 4 Personen aufzubauen und mindestens 2 Stunden zu veranschlagen..

5. Sie sollten den Aufbau auf einem ebenen und flachen Untergrund/Boden vornehmen. Der Boden sollte mit Kartons oder Planen abgedeckt werden um Kratzer an dem Produkt während des Aufbaus zu vermeiden.

Während des Aufbaus sollten alle Schrauben nur leicht angezogen werden. Sobald alle Teile montiert sind müssen alle Schrauben fest angezogen werden.

6. Bitte lehnen Sie keine Leiter an den Pavillion an – nicht während des Aufbaus und auch nicht später bei eventuellen Reinigungen des Daches.

Das klettern auf oder an dem Pavillion und das betreten des Daches ist verboten.

Aufbau Anleitung

1. Die Dachplatten müssen, mit der Seite geschützt von einer dünnen Schutzfolie, zur Sonne/nach oben hin montiert werden.

Diese Schutzfolie sollte erst nach der Montage entfernt werden.

2. Es dürfen keine Wärmequellen oder ein offenes Feuer in oder unter dem Pavillion plaziert werden.

3. Sie können Ihren Pavillion das ganze Jahr über benutzen und stehenlassen. Die maximale Gesamtbelastung für das Dach des Pavillion ist 240 kg. Falls es für eine längere Zeit schneien sollte empfehlen wir das Dach regelmässig von den Schneelasten zu befreien.

Bei extremen Wetterbedingungen wie Hagel oder heftigen Schneefall sollten Sie die Dachplatten sicherheitshalber entfernen und sicher aufbewahren.

Gebrauchshinweise

1. Die Abflussrohre sollten regelmässig von Dreck, Staub und Laub befreit werden um Verstopfung der Rohre zu vermeiden.

2. Von Zeit zu Zeit sollten Sie den Rahmen mit lauwarmen Wasser und mit einem milden Haushaltsreiniger oder Seife reinigen.

3. Die Dachplatten können Sie mit lauwarmen Wasser und mit einem milden Haushaltsreiniger oder Seife reinigen.

Reiniger mit Alkohol, oder sandhaltige Reiniger dürfen nicht verwendet werden.

4. Bevor der ersten Benutzung überprüfen Sie bitte das alle Schrauben fest angezogen sind. Wir schlagen vor die Schrauben in einem 3 monatigen Zeitintervall zu kontrollieren.