

Assembly Instruction

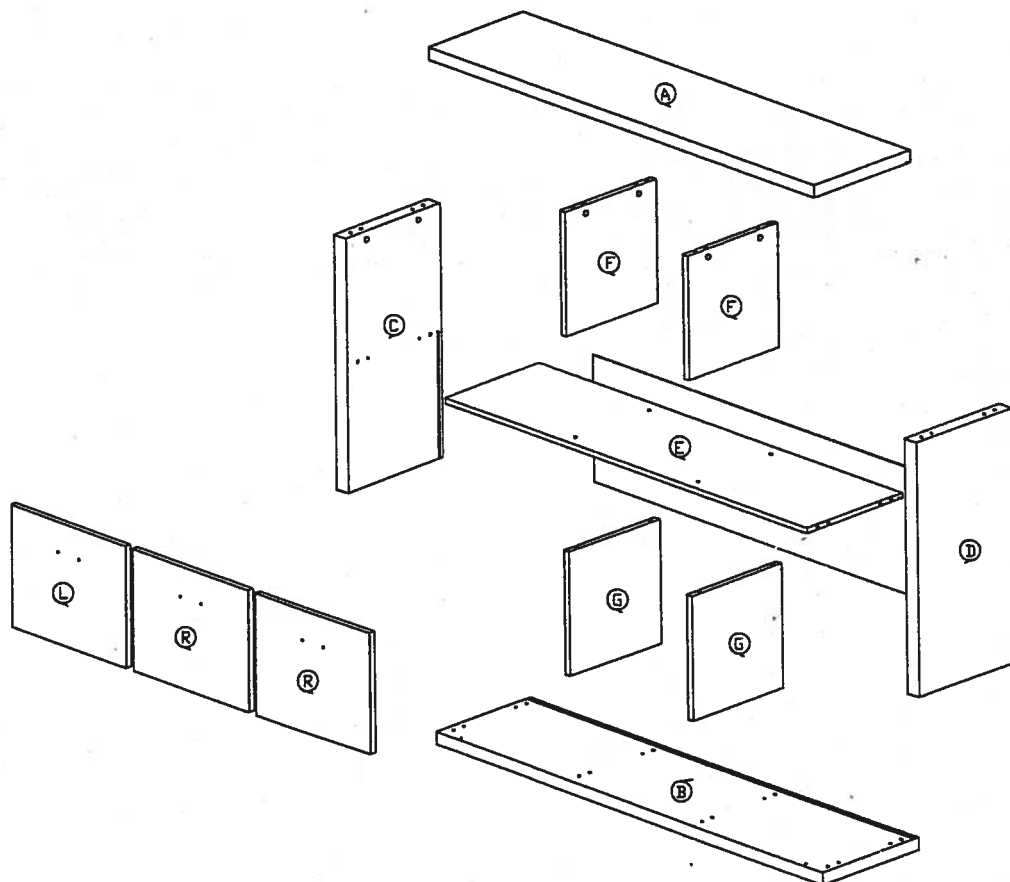







Model : V - 23 H





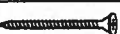

Part List



Assembly Instruction

Hardware List			
1		8x25mm Dowel	20Pcs
2		8x50mm Dowel	4Pcs
3		15MM Myfix Mini Fix	12Sets
4		M3.5x15mm Screw	28Pcs
5		M4x65mm Screw	8Pcs
6		Nail	8Pcs
7		Handle-84 M3.6x24mm Screw	3Sets
8		MT Stopper	6Pcs

9		Brown Magnet 2 Pin Flat Head Tapping Screw M6x10mm ZB	3Sets
10		OS-140mm Long Tapper Stand	4Pcs
11		15MM Mini Fix Cap	4Pcs
12		15MM Mini Fix Cap	4Pcs

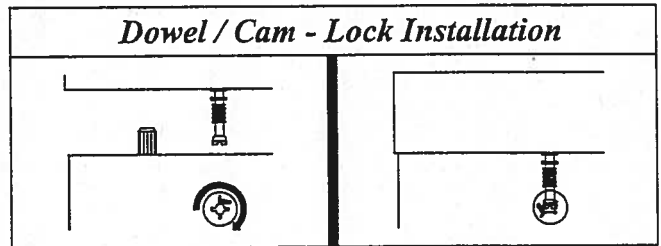

STEP 1

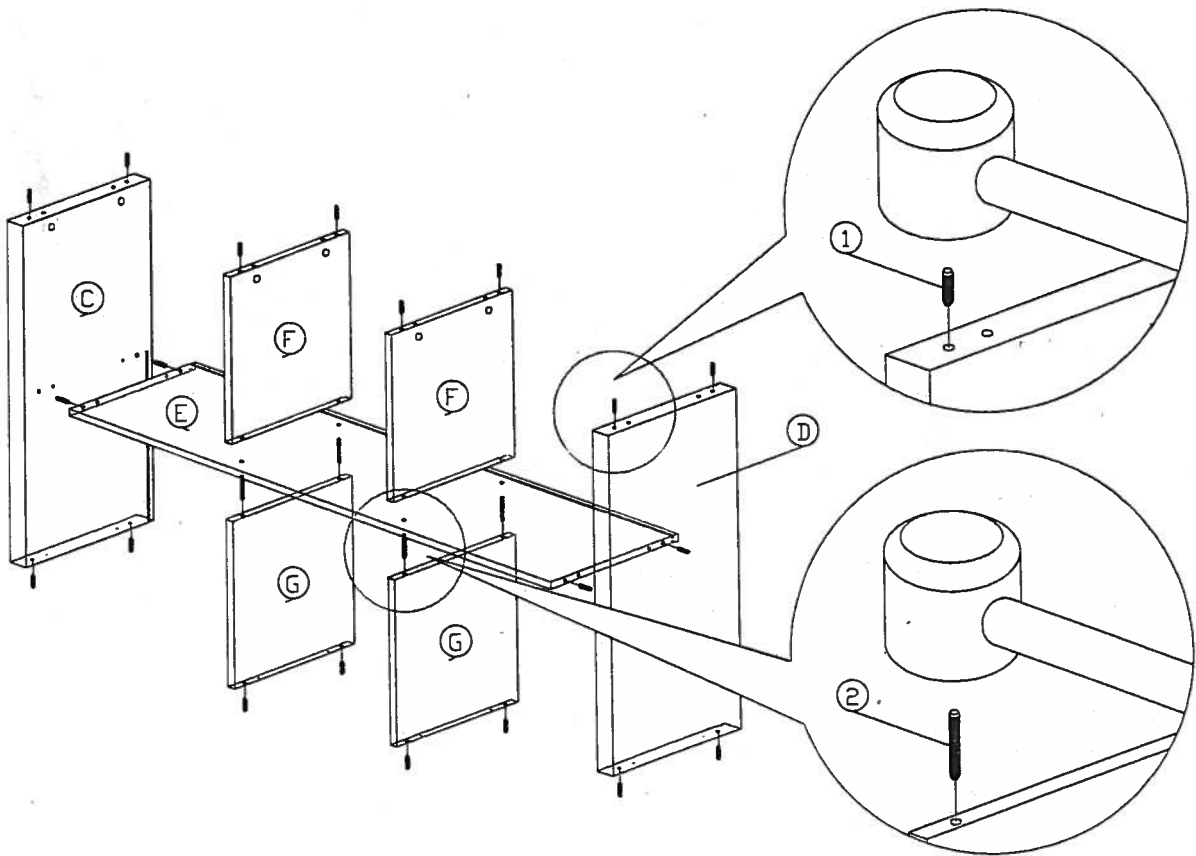

Assembly Instruction

STEP 2

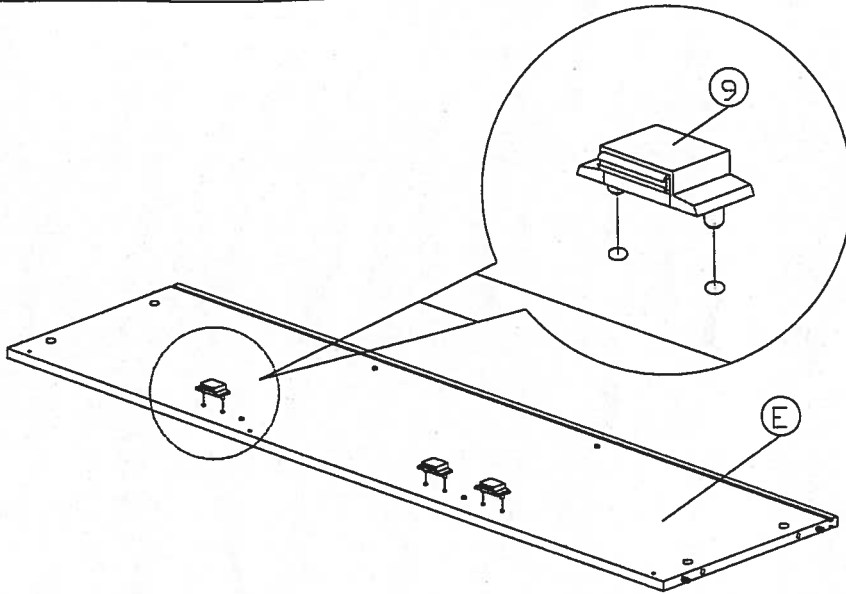

STEP 3

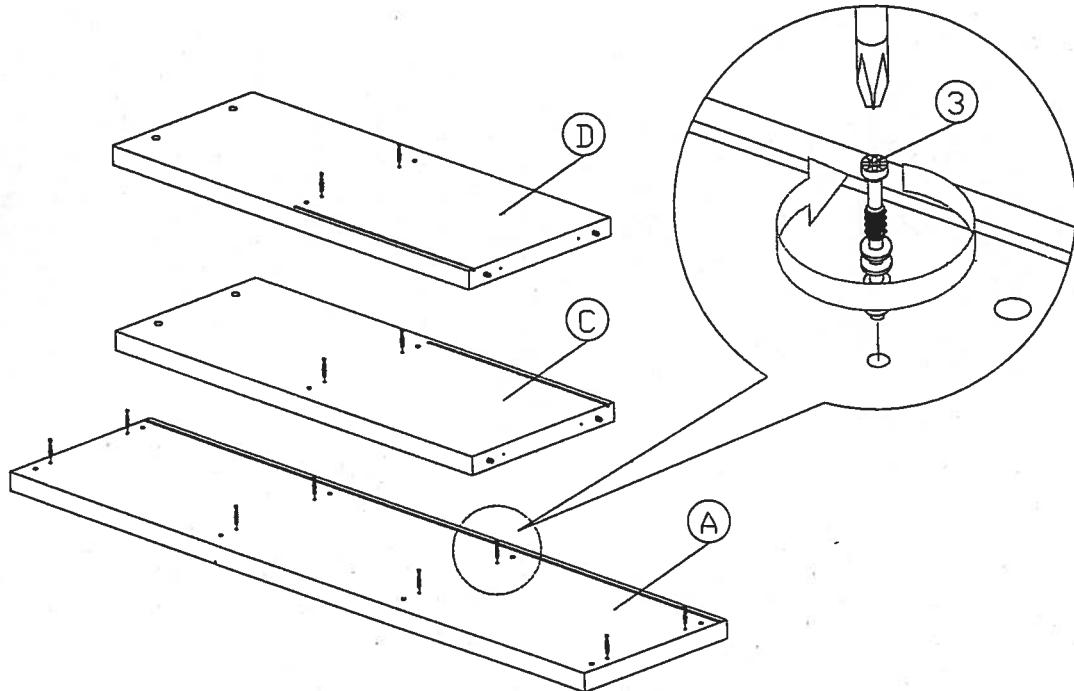

Assembly Instruction

STEP 4

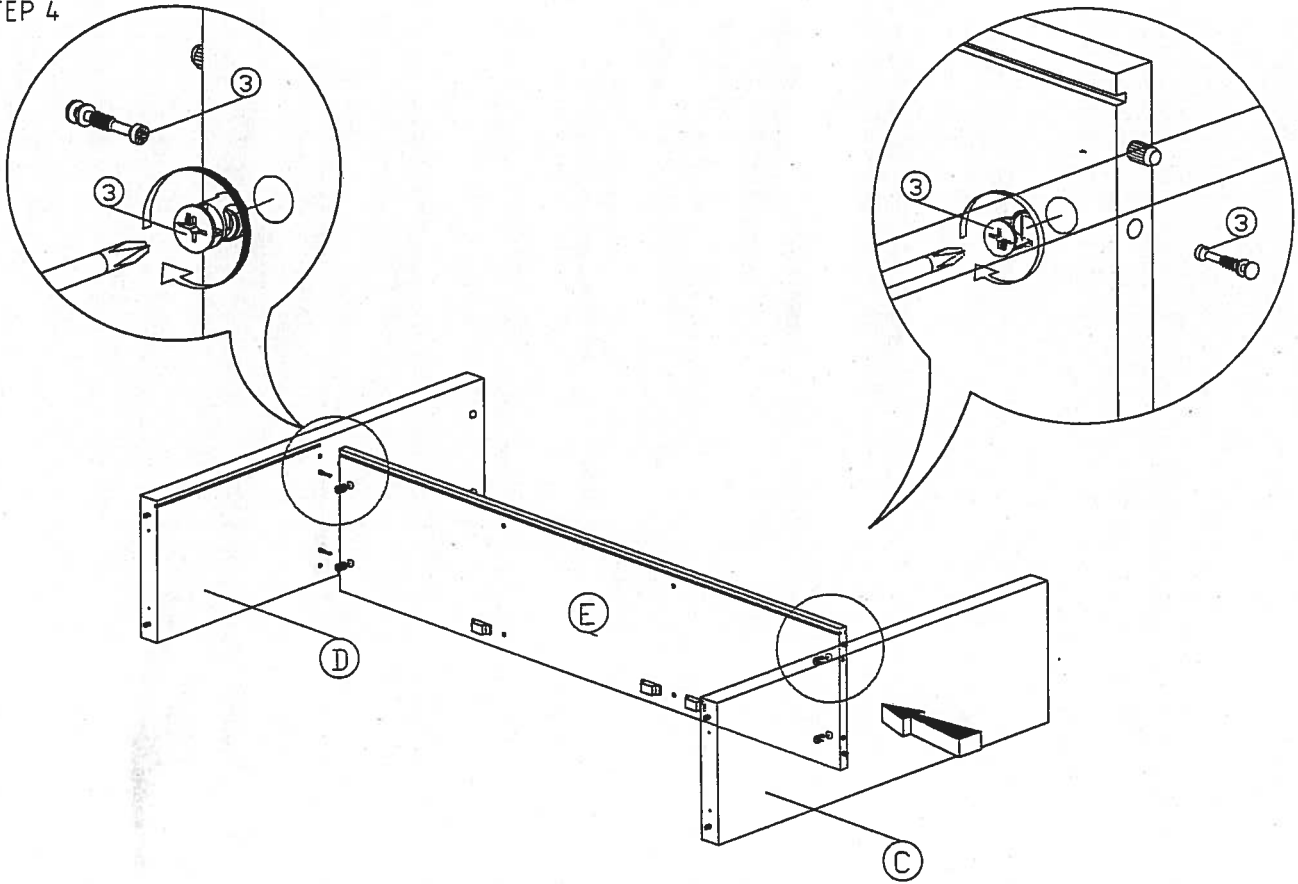

STEP 5

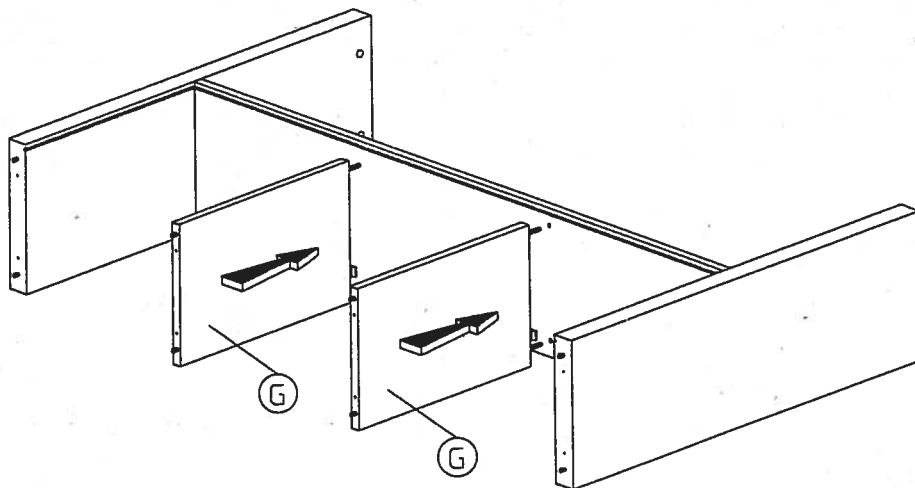

Assembly Instruction

STEP 6

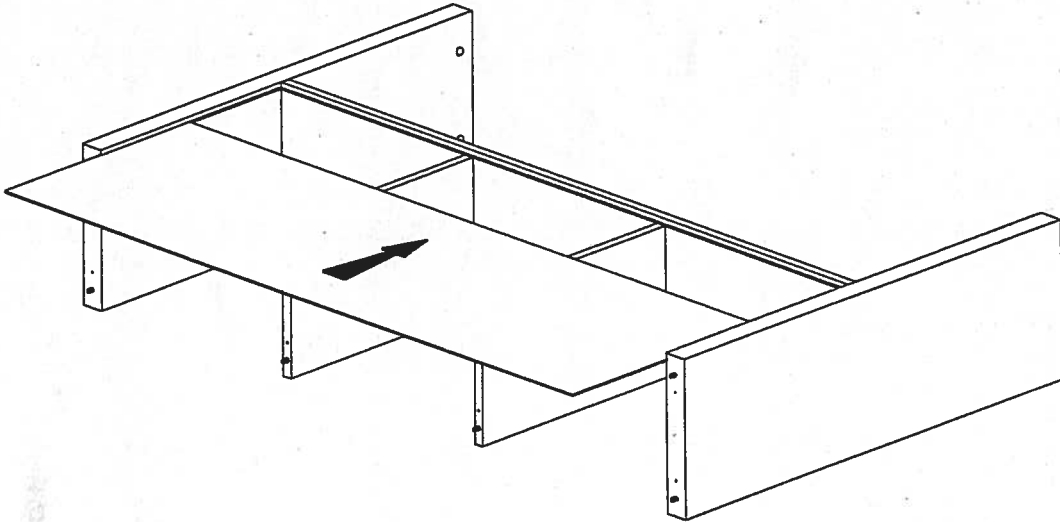

STEP 7

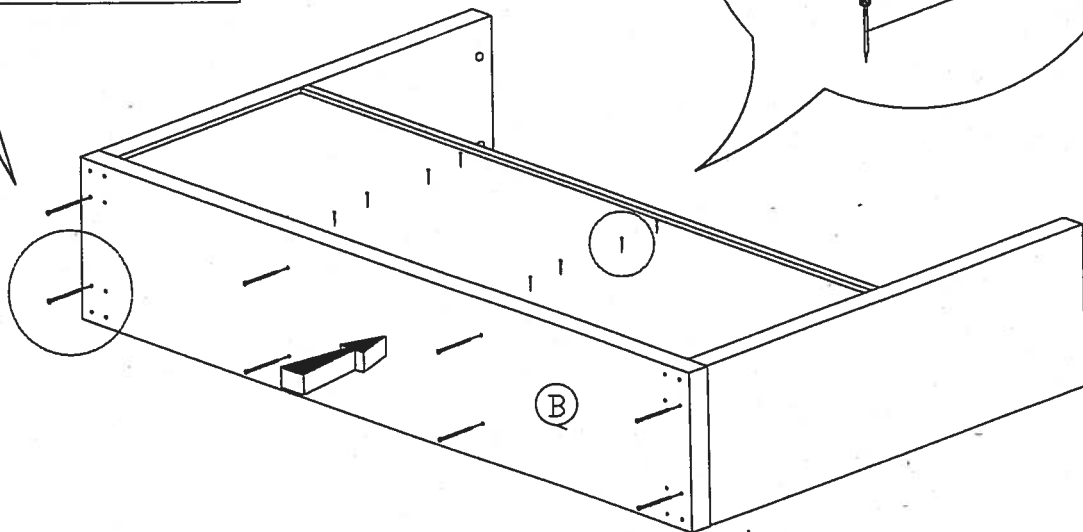
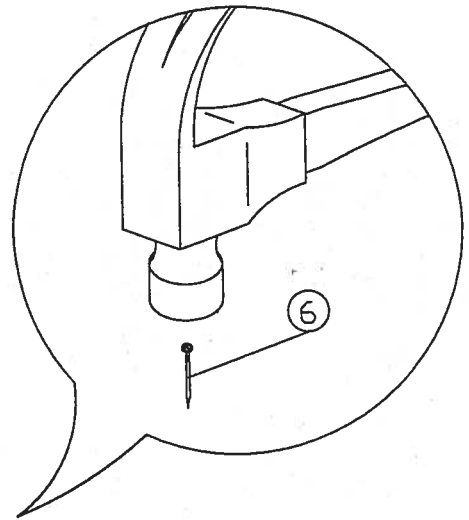
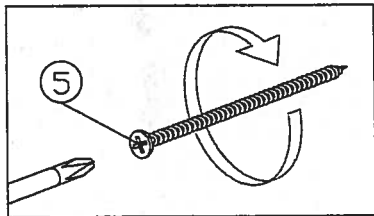

Assembly Instruction

STEP 8

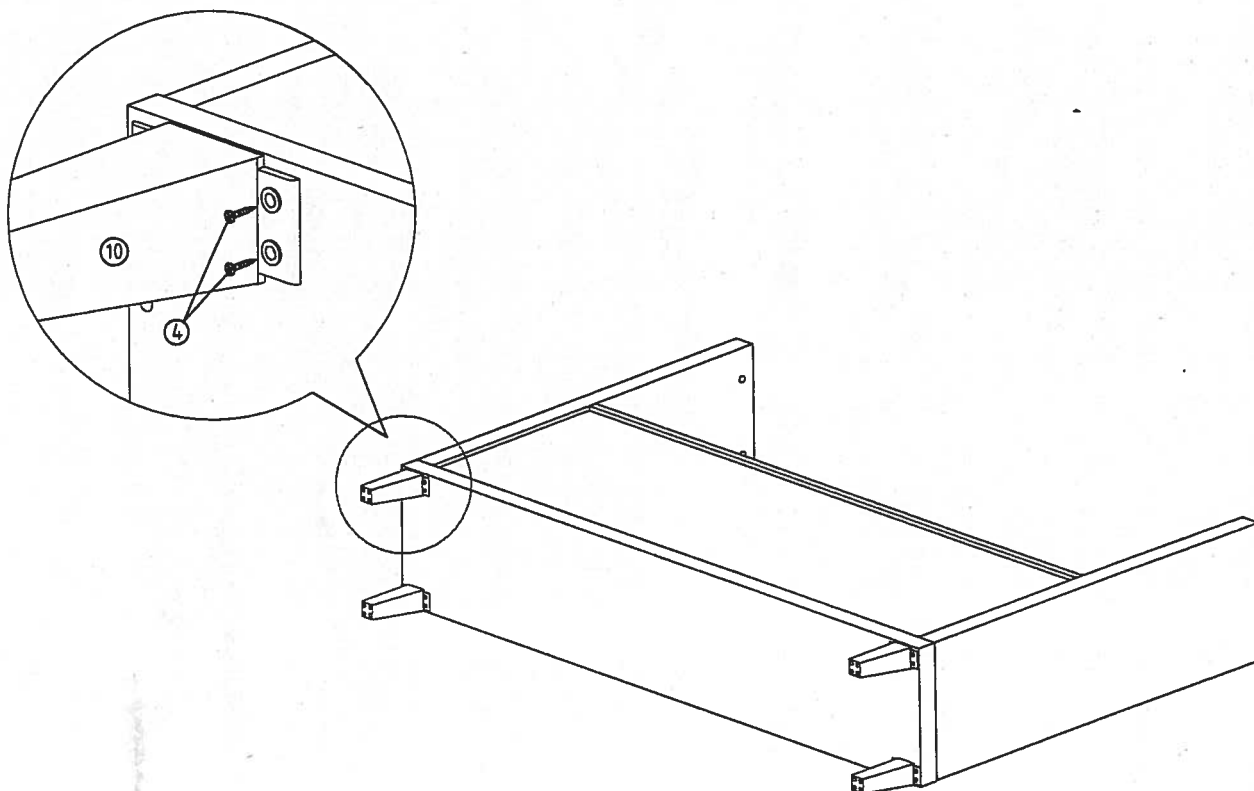

STEP 9

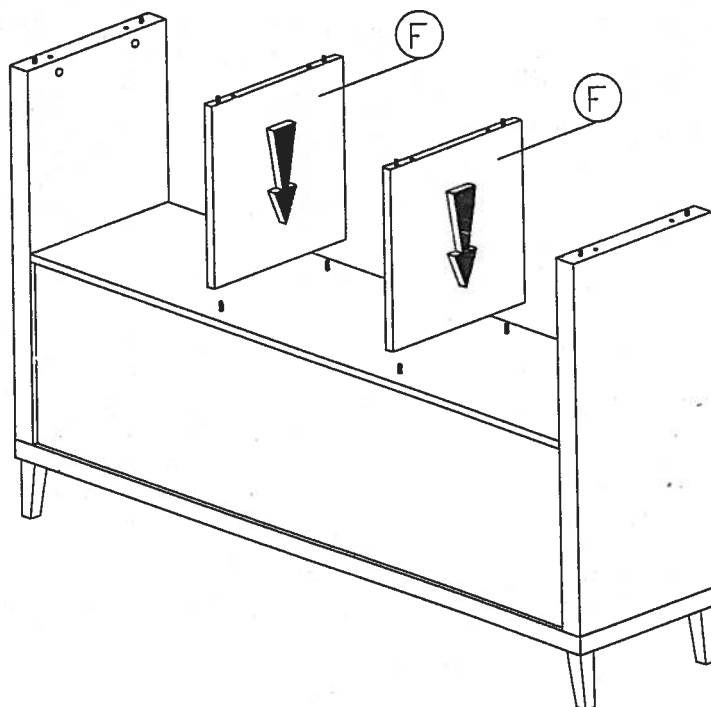

Assembly Instruction

STEP 10

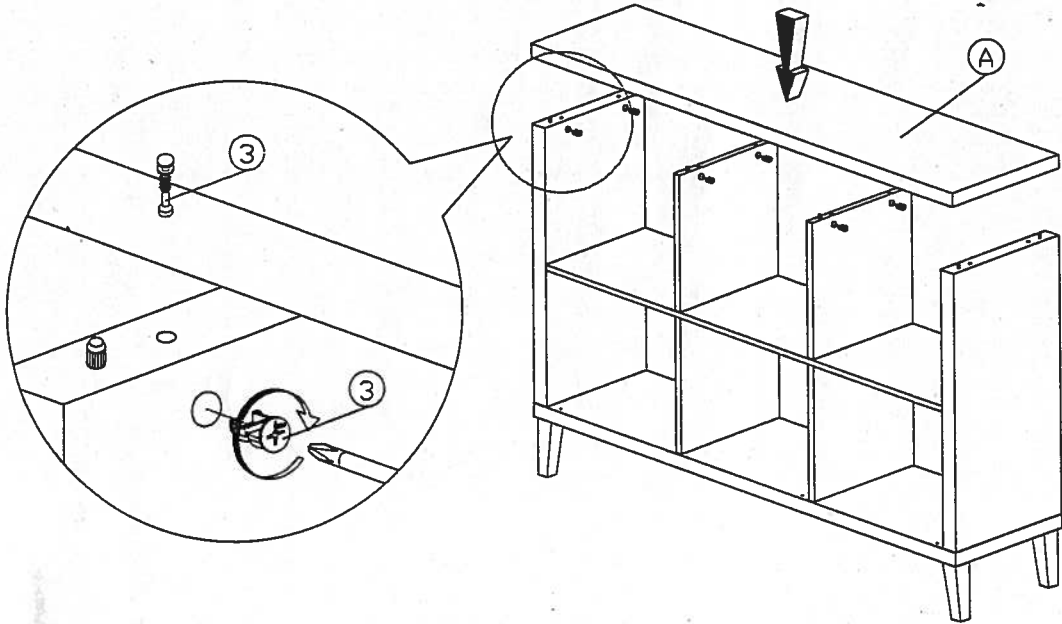

STEP 11

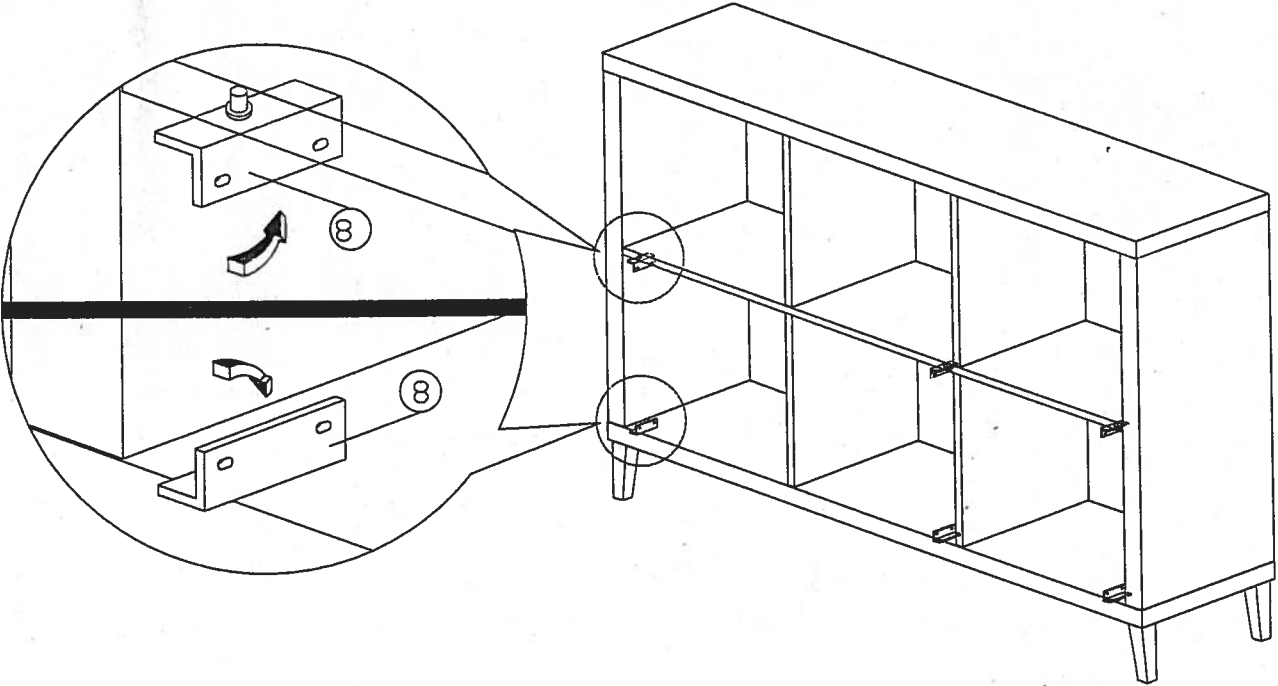

Assembly Instruction

STEP 12

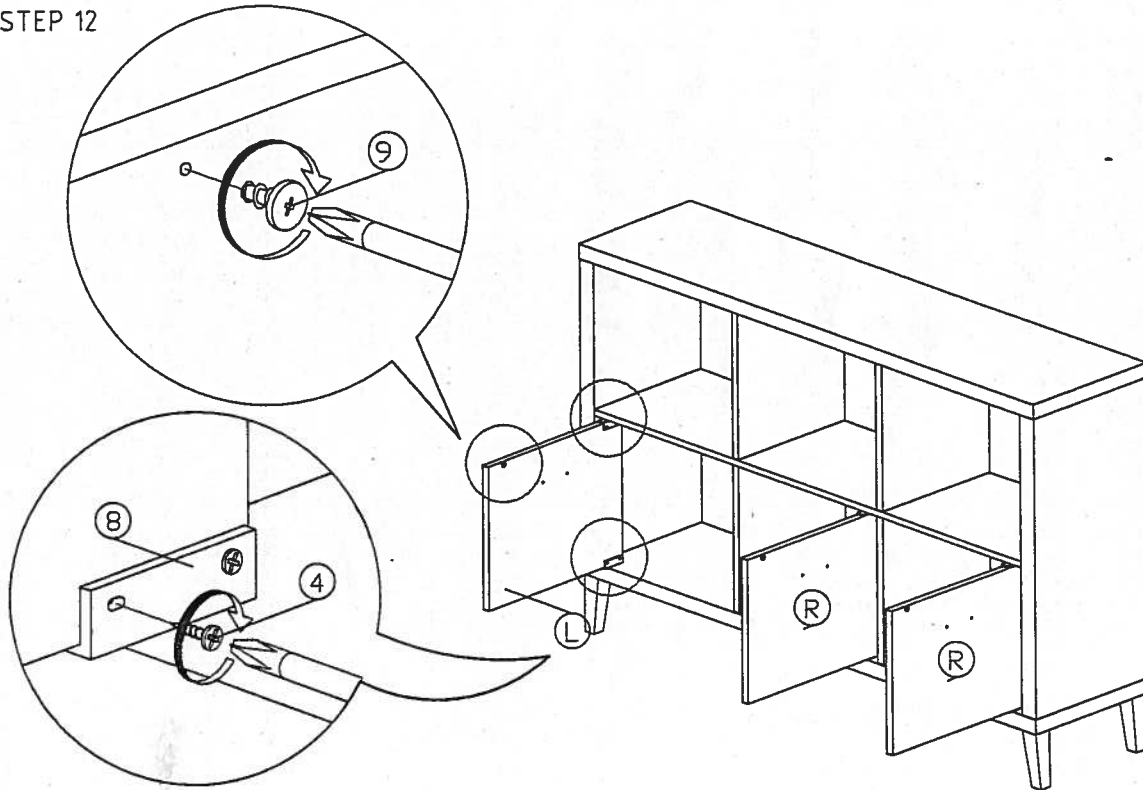

STEP 13

