

Schaukelsessel

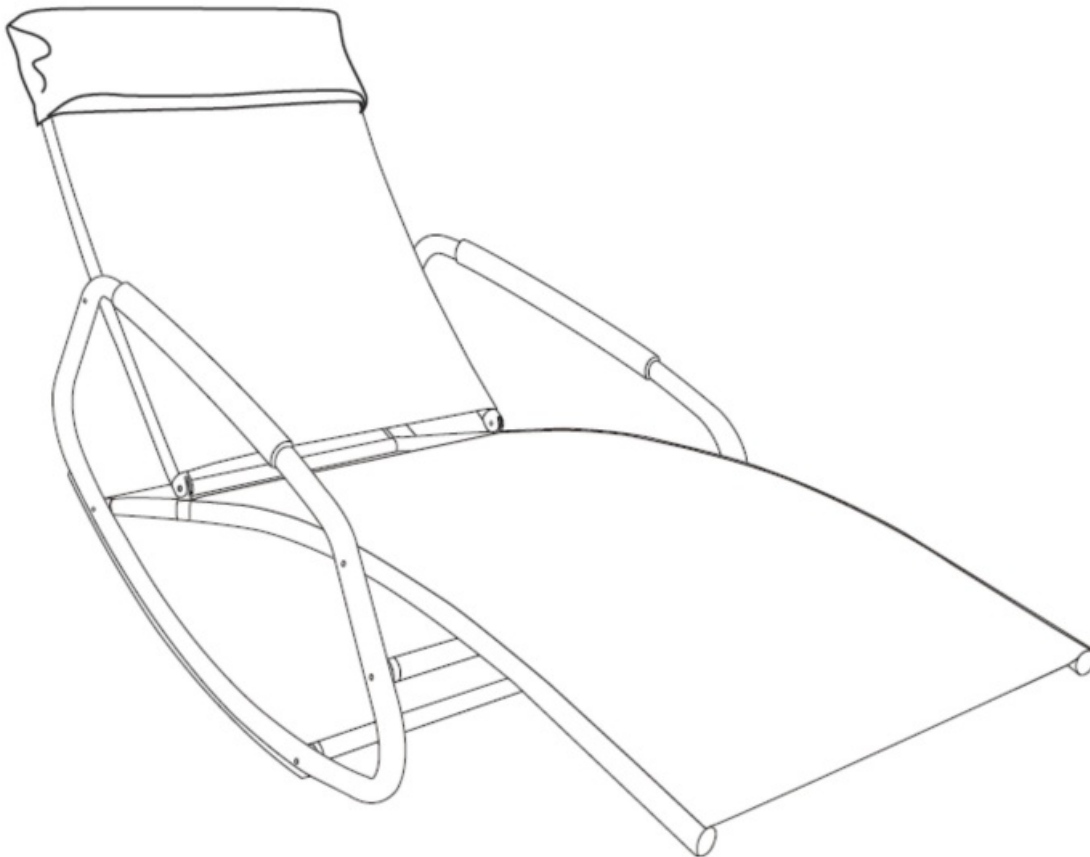

Swing Chair

Swing Stoel



Vor Montage und Benutzung unbedingt sorgfältig lesen und für spätere Zwecke aufbewahren.

Read these instructions carefully before use and assembly and keep for future reference!

Lees deze instructies zorgvuldig door en bewaar ze ter referentie in de toekomst!

Schaukelsessel



Swing Chair

Swing Stoel

Ersatzteilliste / Spare part list / Onderdelenlijst

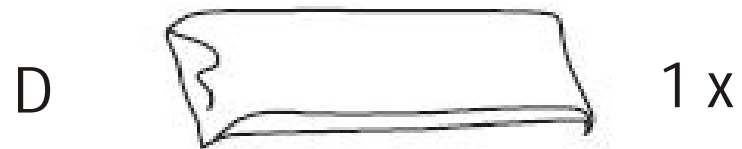
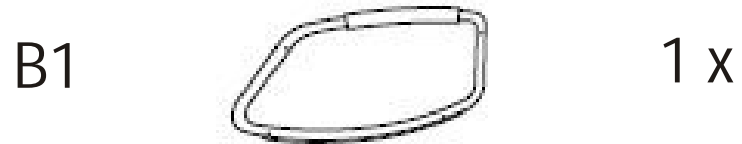
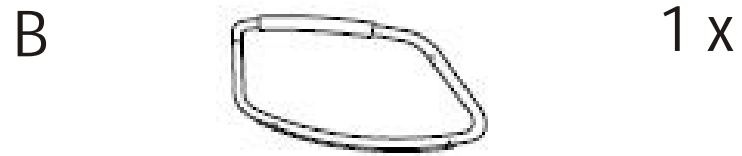

Hinweis / Information / Informatie:
VORSICHT SCHERSTELLEN MOEGLICH!
QUETSCHGEFAHR AN TEILEN MOEGLICH!
KLEINKINDER NIE UNBEAUFICHTIGT
LASSEN! AUSSER REICHWEITE VON KINDERN
AUFBEWAHREN!

CAUTION SCISSOR ACTION ! RISK OF INJURY
BY CRUSHING! NEVER LEAVE CHILDREN
UNATTENDED ! KEEP OUT OF REACH OF
CHILDREN !

VOORZICHTIG SCHAARPLAATSEN !
KNEUSGEVAAR ! KLEINE KINDEREN NOOIT
ZONDER TOEZICHT LATEN ! BUITEN HET
BEREIK VAN KINDEREN BEWAAREN !

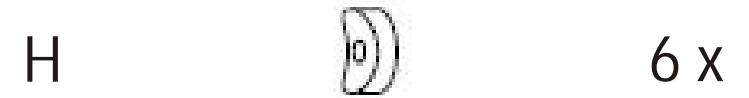
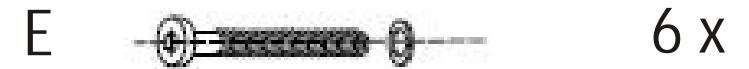

Schaukelsessel

Swing Chair

Swing Stoel

Aufbauanleitung / Assembly instruction / Opbouw instructie

①

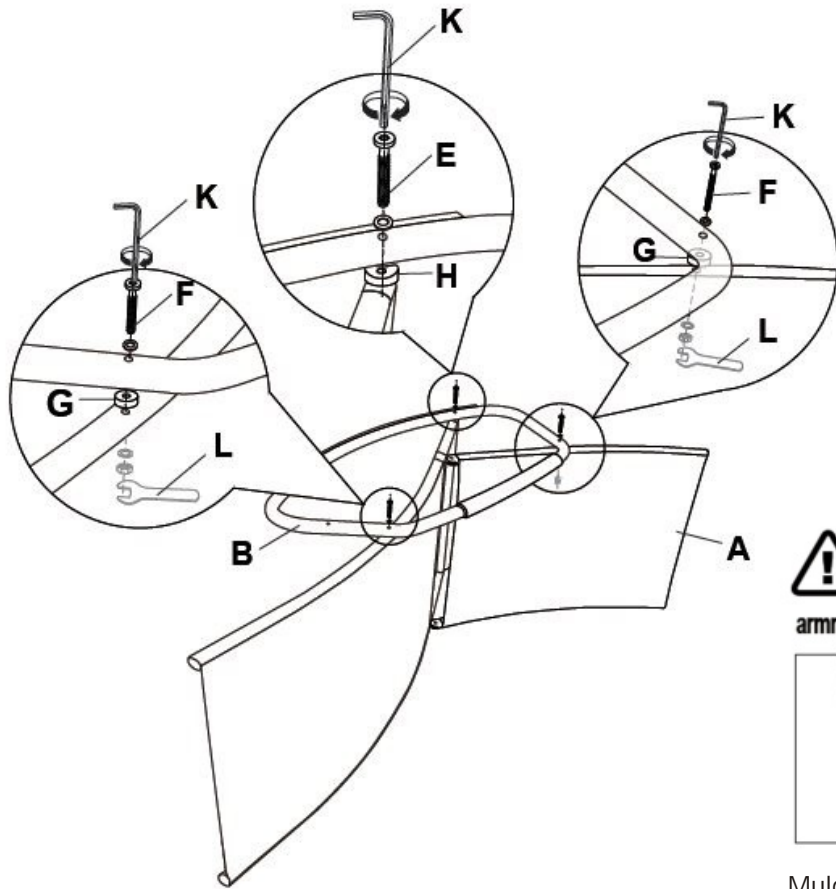

armrest notch towards outer side

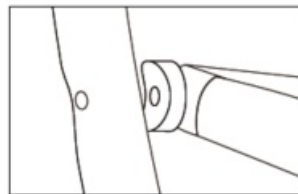

Mulde an der Armlehne zur Außenseite!!

②

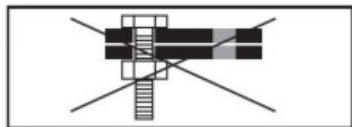
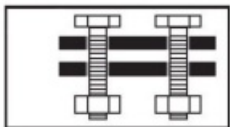
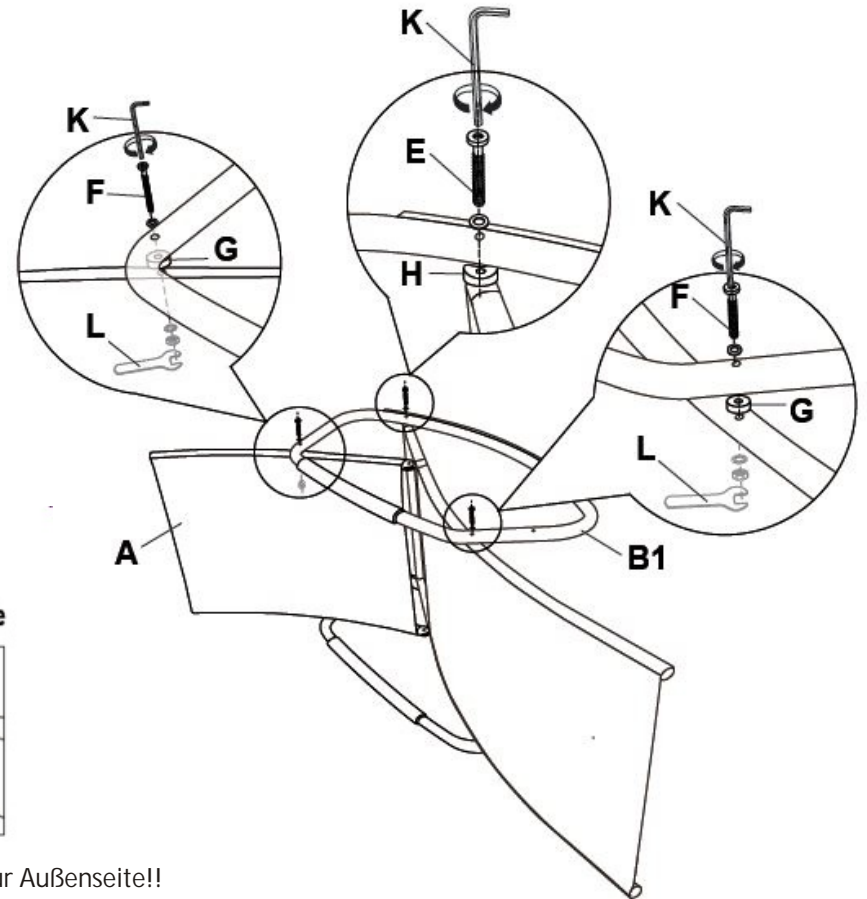

Alle Schrauben nur loose anziehen!
All screws just tighten loose!
Alle schroeven los aandraaien!

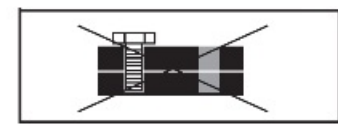
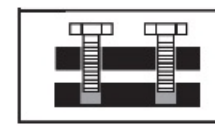

Schaukelsessel

Swing Chair

Swing Stoel

Aufbauanleitung / Assembly instruction / Opbouw instructie

③

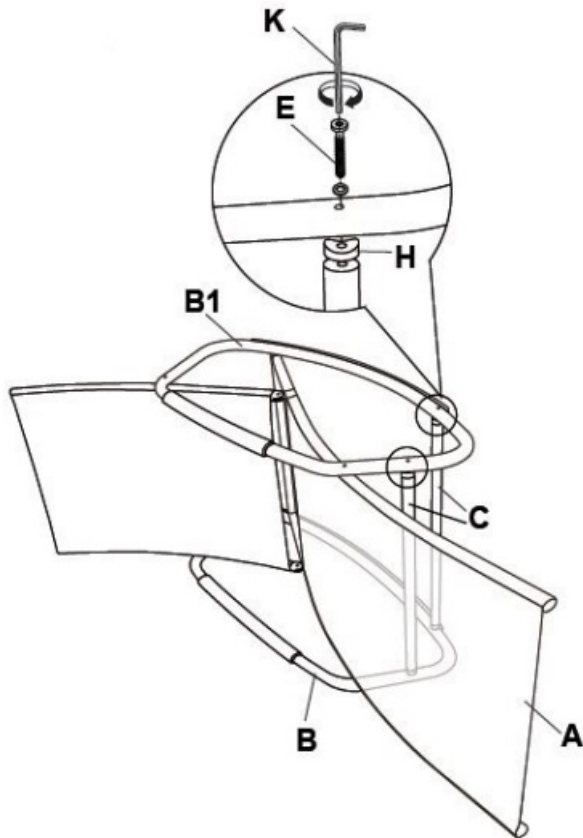

④

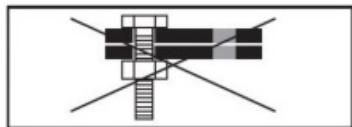
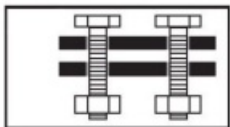
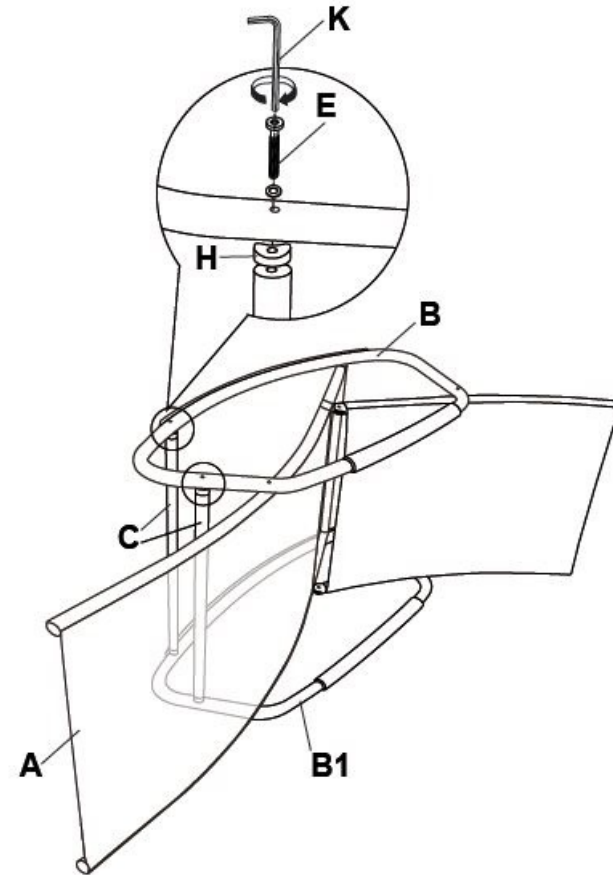

Alle Schrauben nur loose anziehen!
All screws just tighten loose!
Alle schroeven los aandraaien!

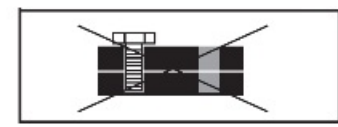
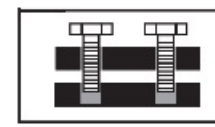

Schaukelsessel



Swing Chair

Swing Stoel

Aufbauanleitung / Assembly instruction / Opbouw instructie

⑤

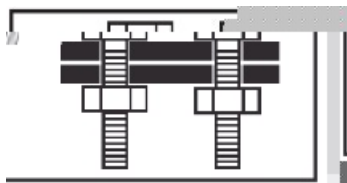
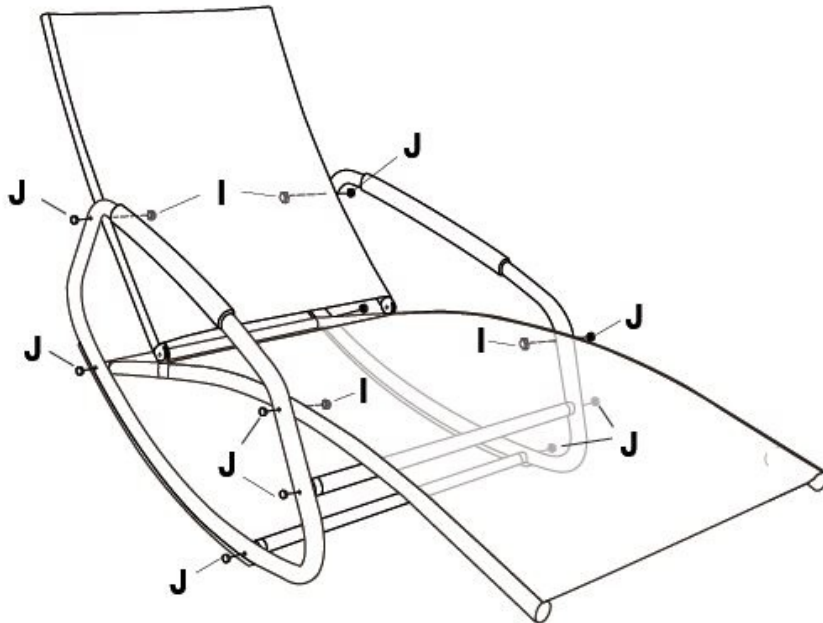

⑥

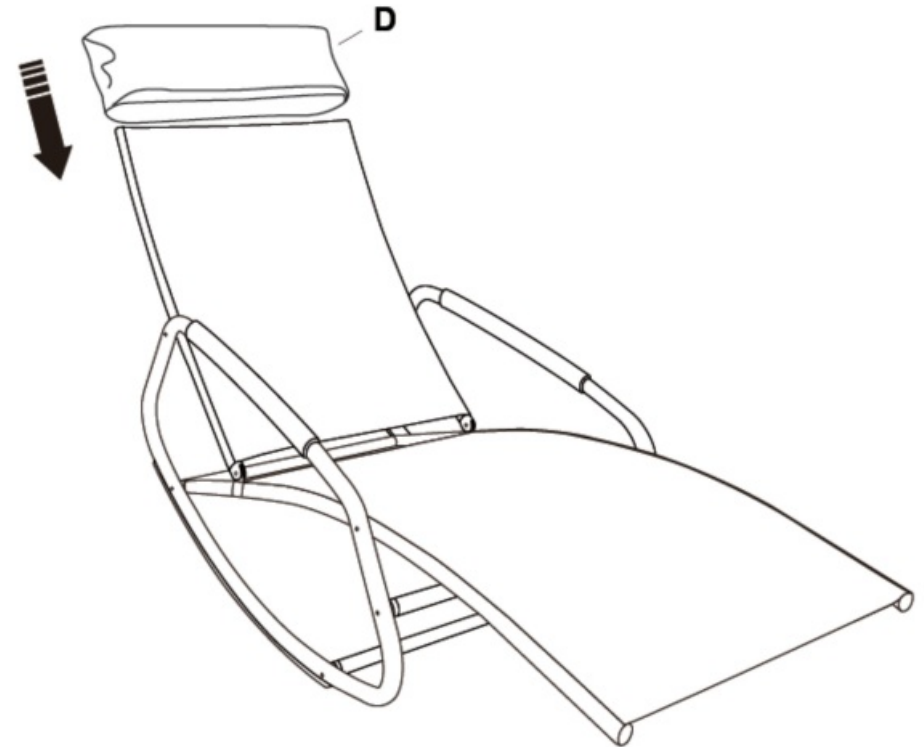

Nun alle Schrauben fest anziehen!
Now please tighten screws firmly!
Nu schroeven vast aandraaien!

Schaukelsessel



Swing Chair

Swing Stoel

Aufbauanleitung / Assembly instruction / Opbouw instructie

Max. Belastung (1 Person)
Max. Load Capacity (1 Person)
Max. Belasting (1 persoon)

110 KG

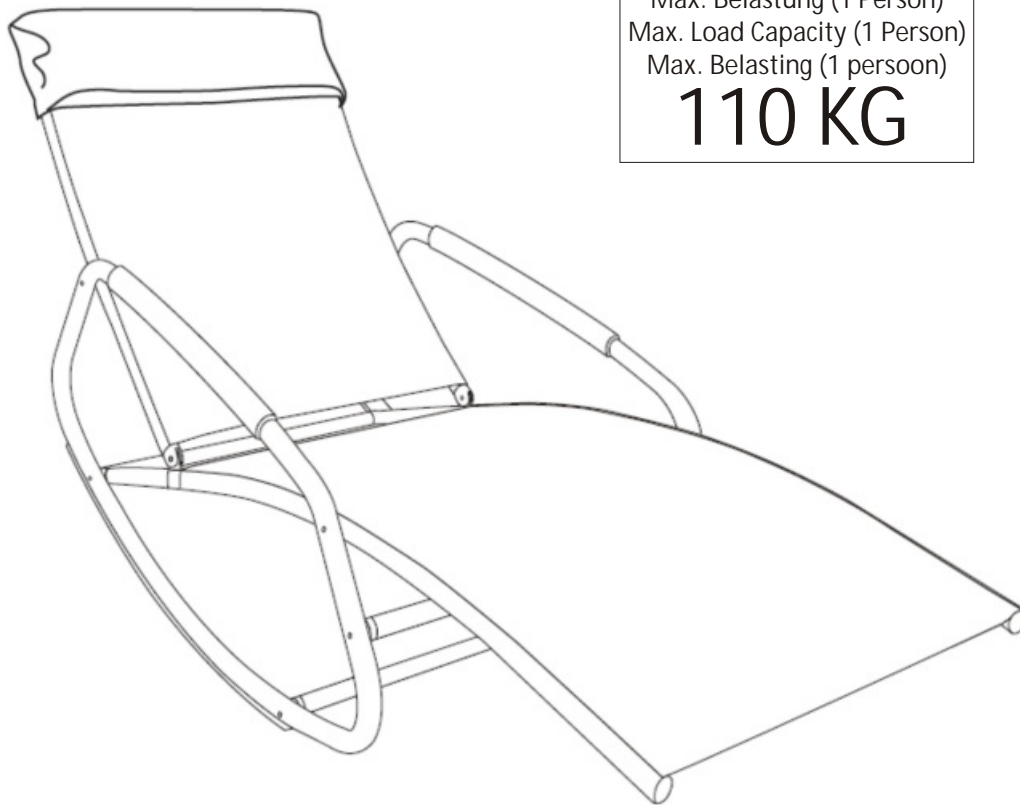

Regelmässig alle Schrauben kontrollieren!
Bitte vorsichtig einsteigen und benutzen!

Please control all screws regularly!
Please enter and use carefully!

Controleer alle schroeven regelmatig!
Wees voorzichtig bij het gaan zitten en het gebruik!

Nur fuer die Nutzung im Privatbereich. Die gewerbliche Nutzung ist untersagt! Keine Nutzung als Sport- oder Fitnessgerät!
Vorsicht bei der Nutzung auf weichen Rasenflächen. Nur für die Nutzung auf ebenem Untergrund.

This product is only for the private sector. Any commercial use is prohibited! No use as sports or fitness equipment!
Caution by use on soft lawns. Only use on even floors and grounds.

Dit product is alleen voor gebruik in de particuliere sector. Een commercieel gebruik is verboden! Geen gebruik als een sport of fitnessapparatuur!

Let op bij het gebruik op zachte gazons. Alleen voor het gebruik op een vlakke en gladde odergrond.