

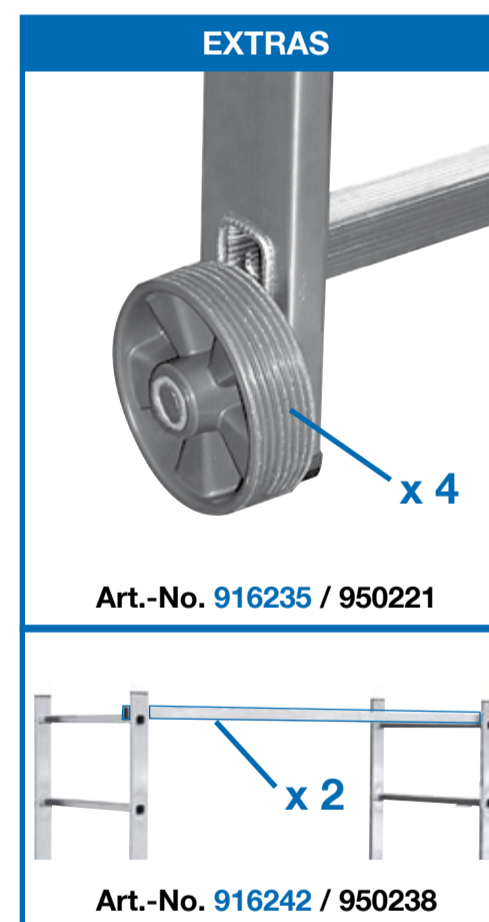

CORDA®

- | | | |
|----------------------------------|---------------------------|----------------------------|
| DE PlattformGerüst | DK Platformstillads | IT Ponteggio a piattaforma |
| GB Platform scaffold | EE Platvormtelling | NL Platformsteiger |
| PL Rusztowanie składane podwójne | ES Bastidor de plataforma | NO Plattformstativ |
| RU Вышка с платформой | FR Ossature de plateforme | RO Schelă cu platformă |
| HU Dobogós állvány | FI Rakennusteline | SE Plattformställning |
| BA Skela sa platformom | GR Ικρίωμα πλατφόρμας | SI Ogradje platforme |
| BG Скеле с платформа | HR Platforma skele | SK Lešenie s plošinou |
| CZ PlattformGerüst | | TR Platform iskelesi |

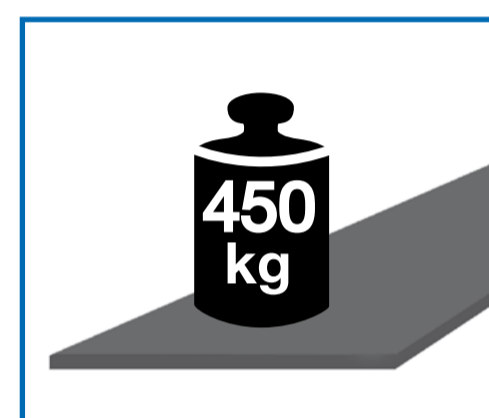
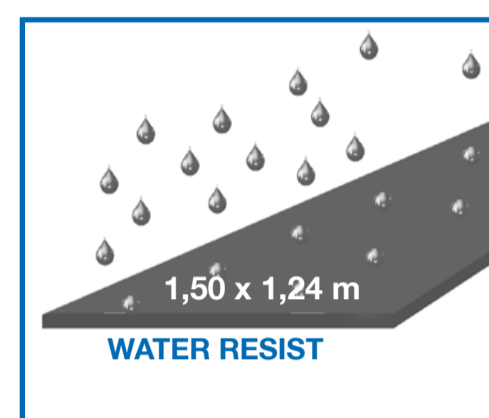
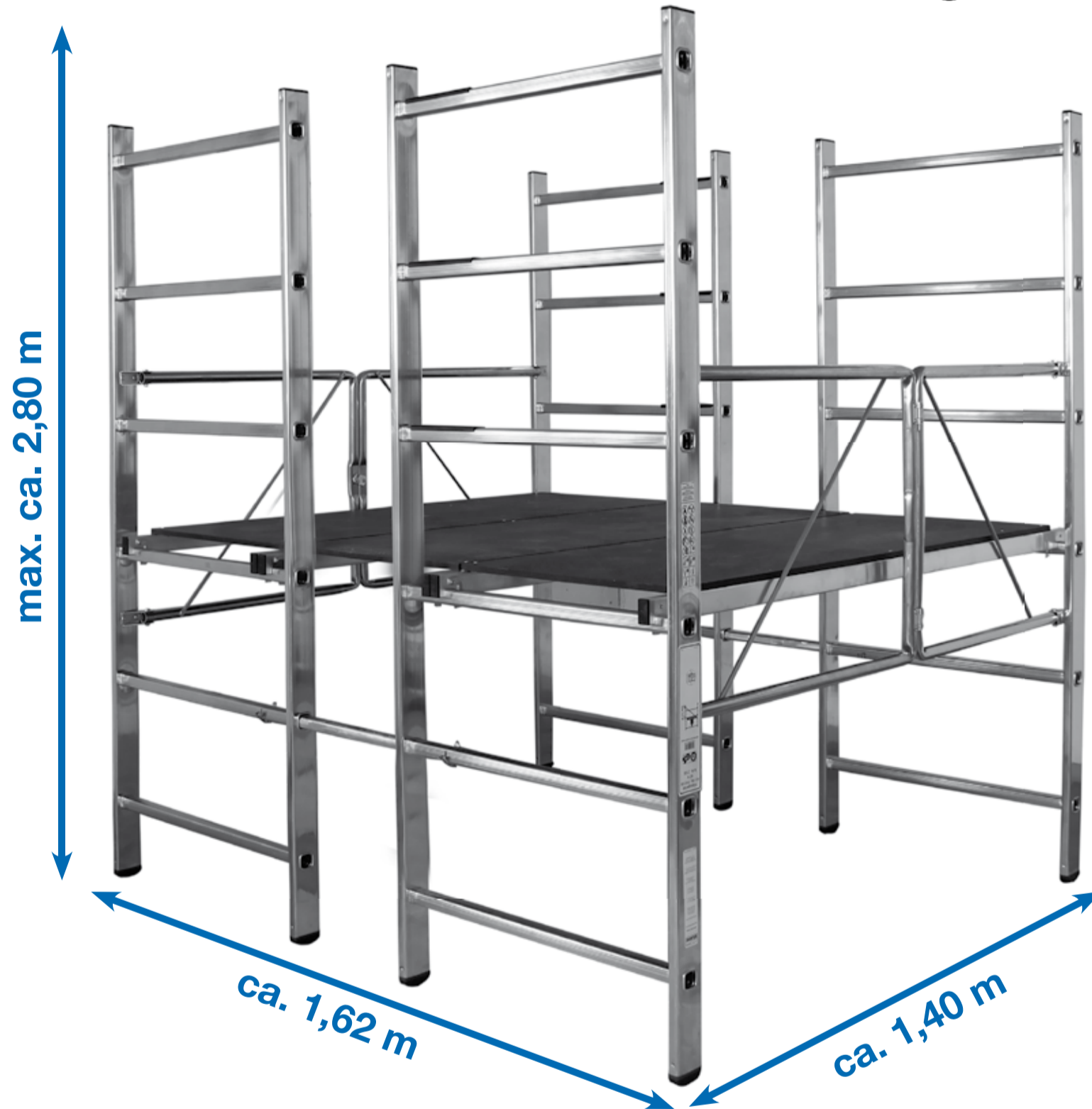

Art.-No. 916228 / 950214

← ca. 2,80 m
 ⬆ ca. 37 kg

(ca. m)

BGR 173

max. 450 kg



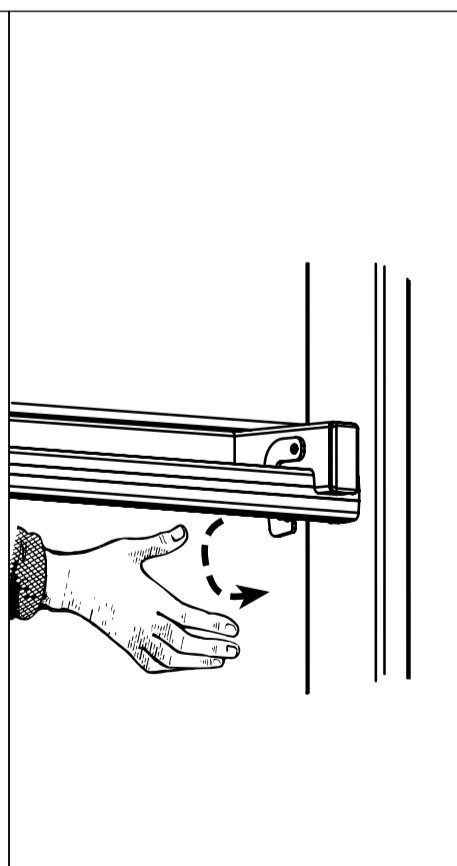
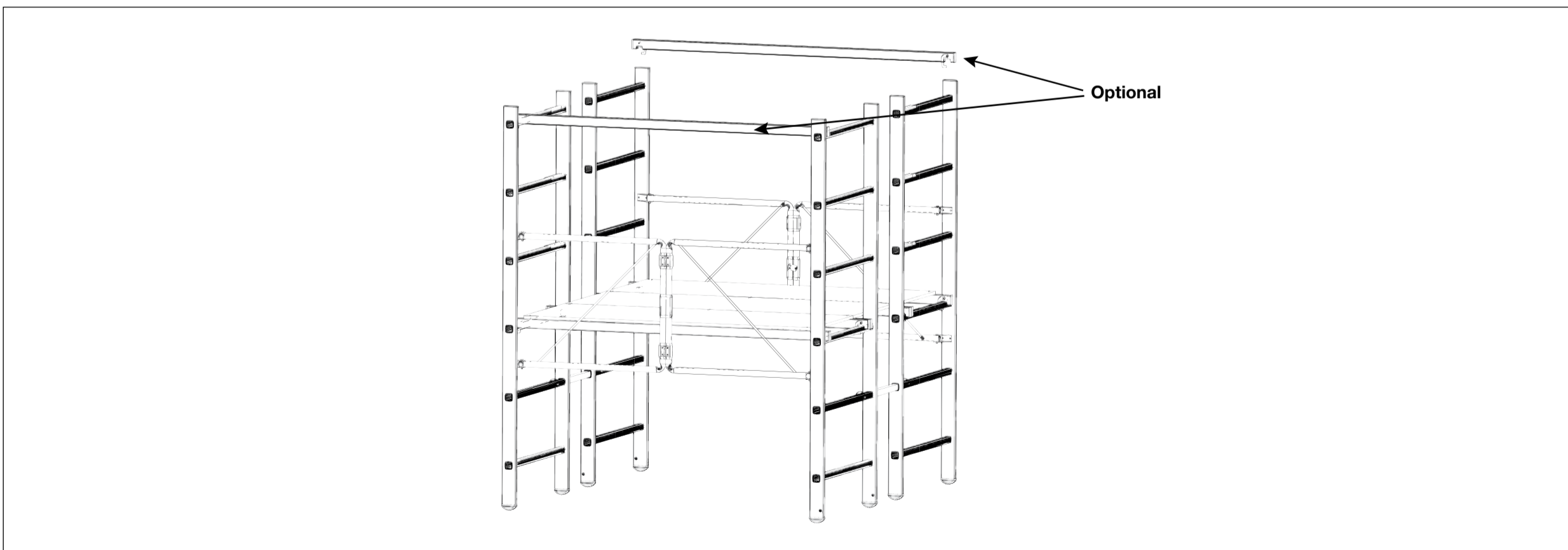
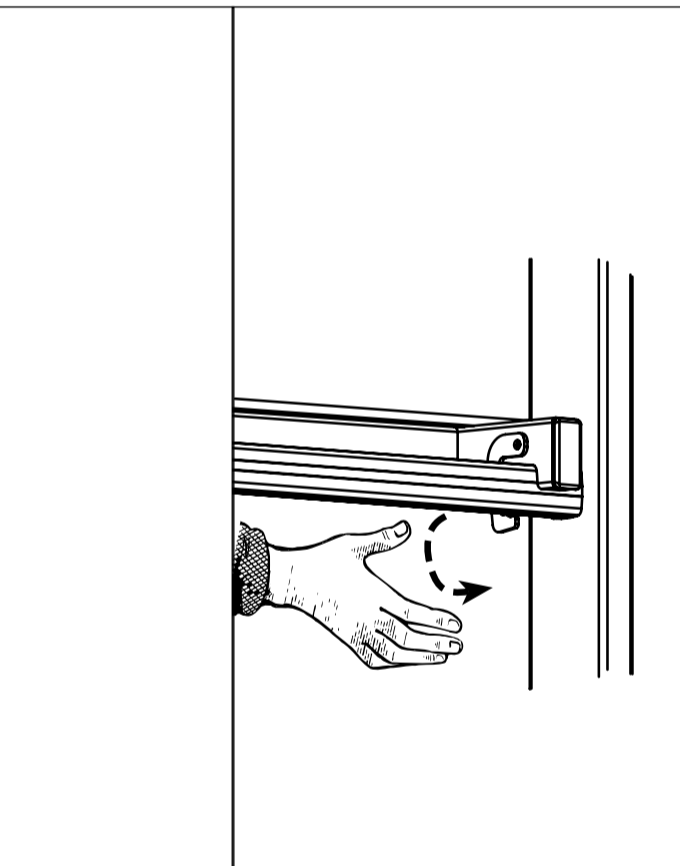
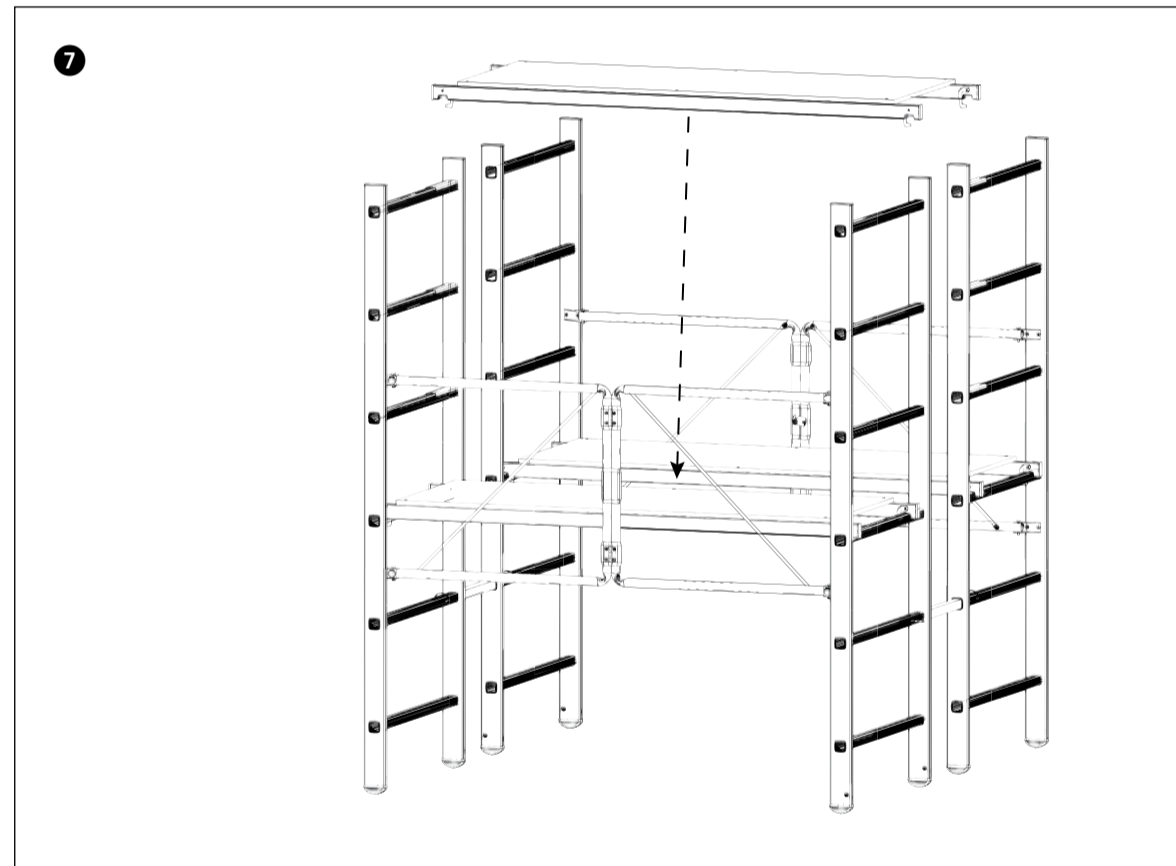
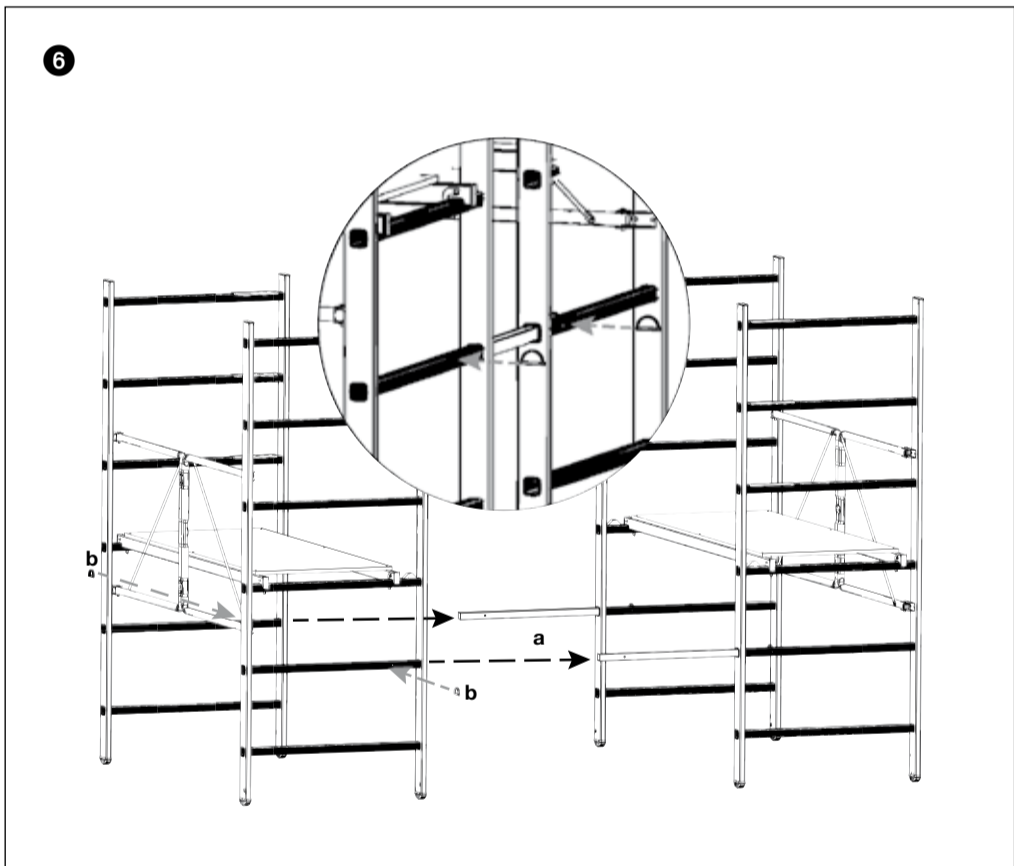
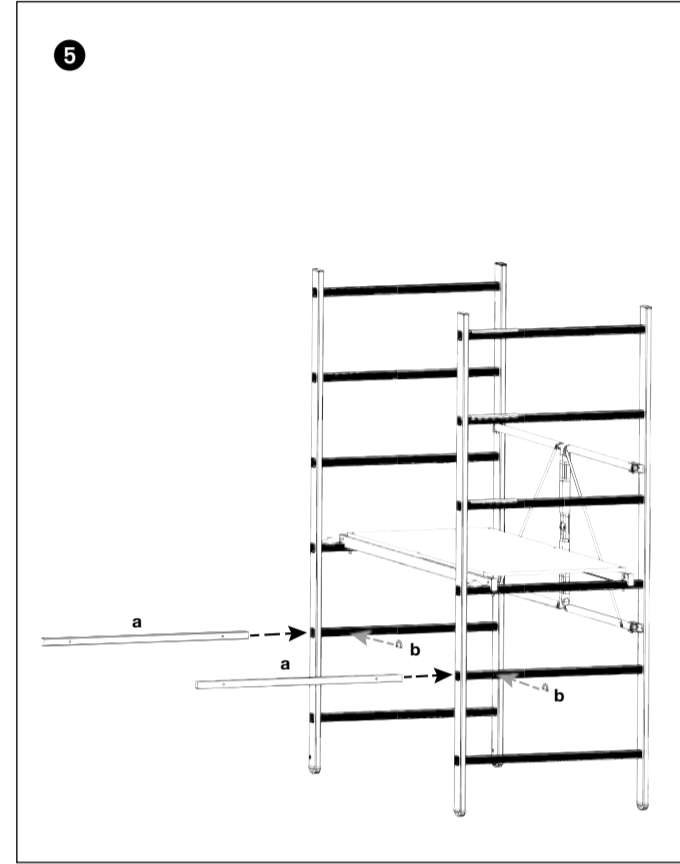
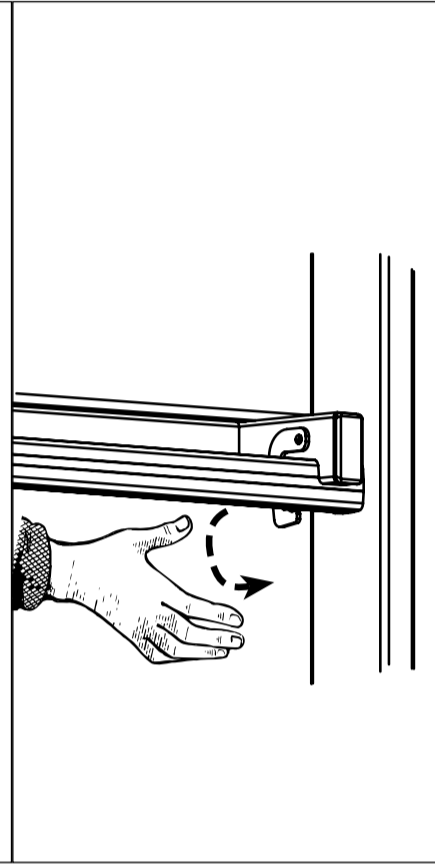
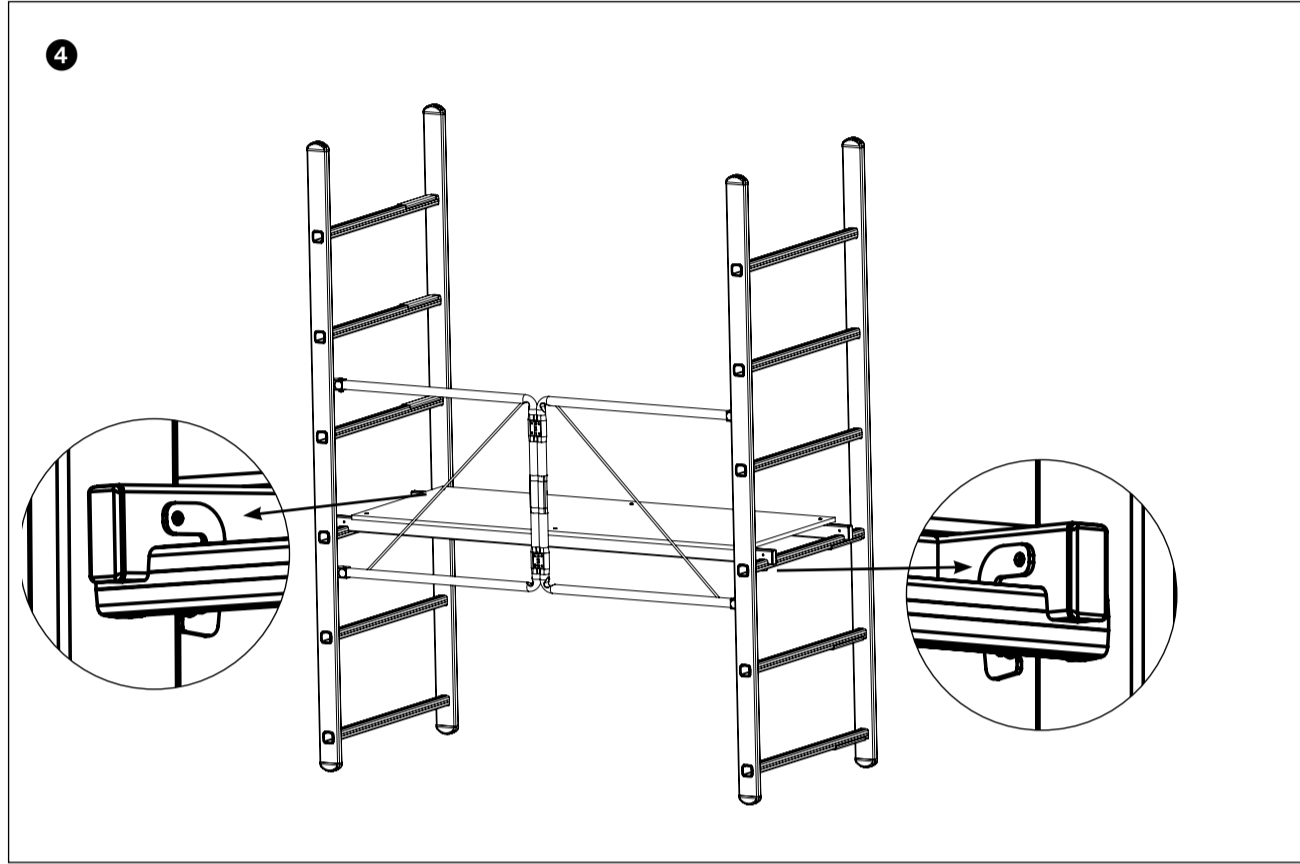
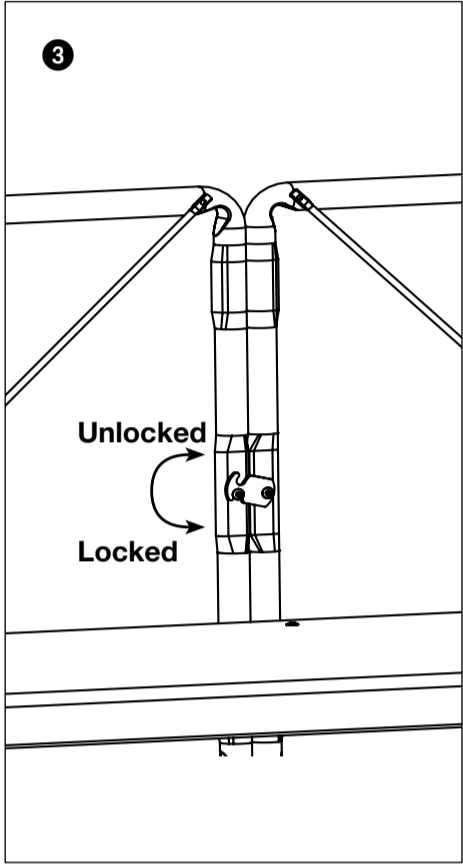
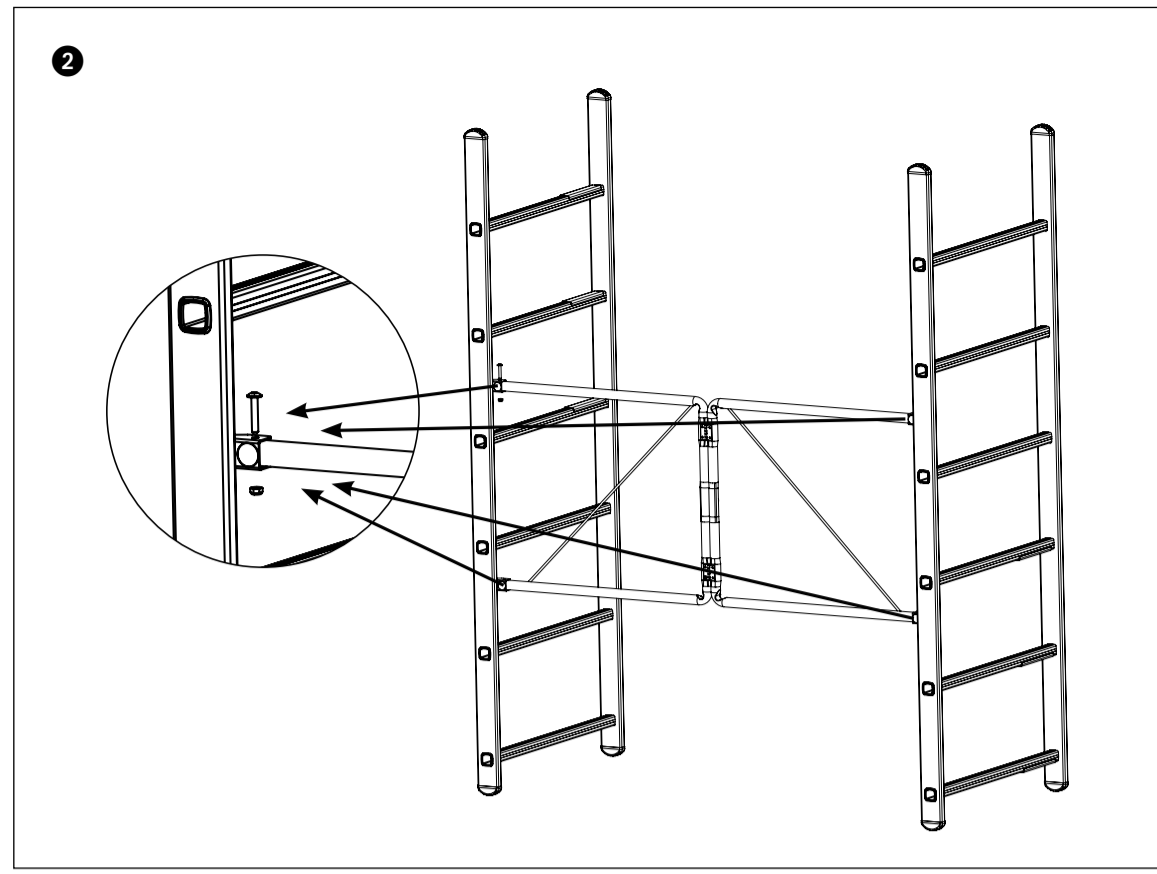
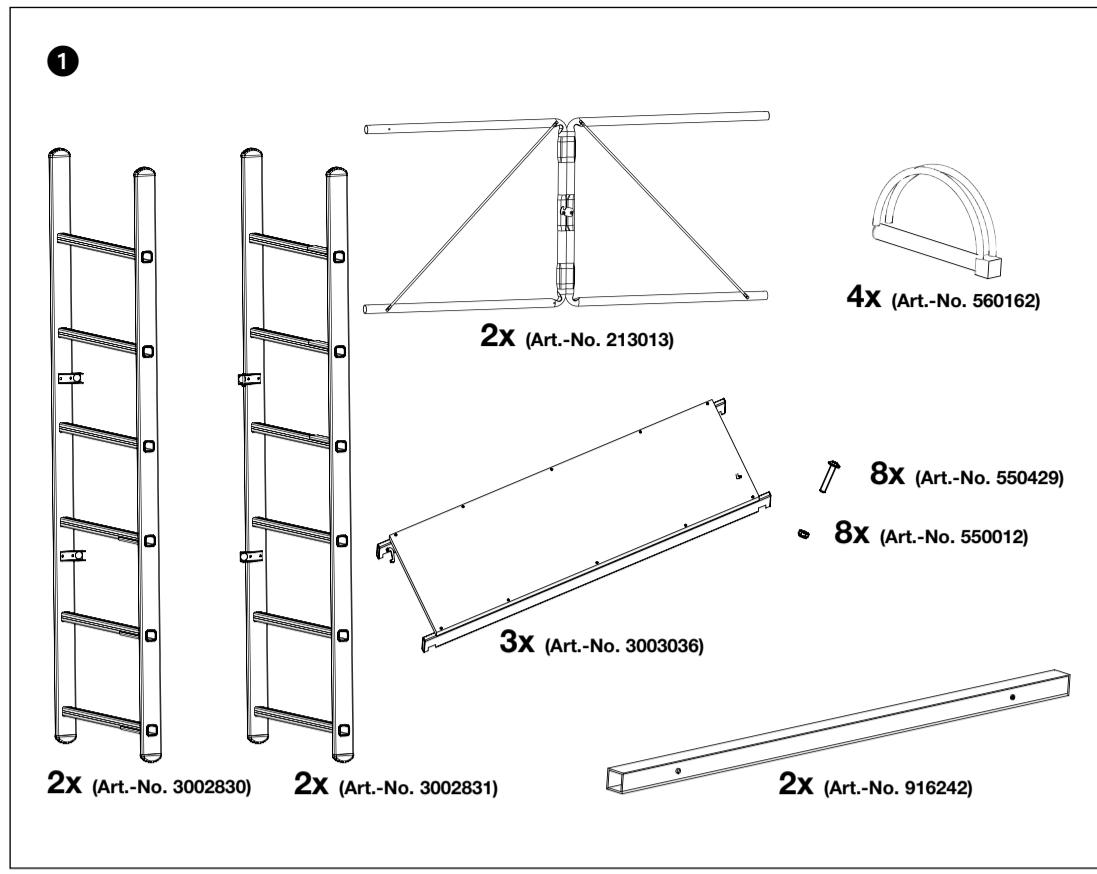
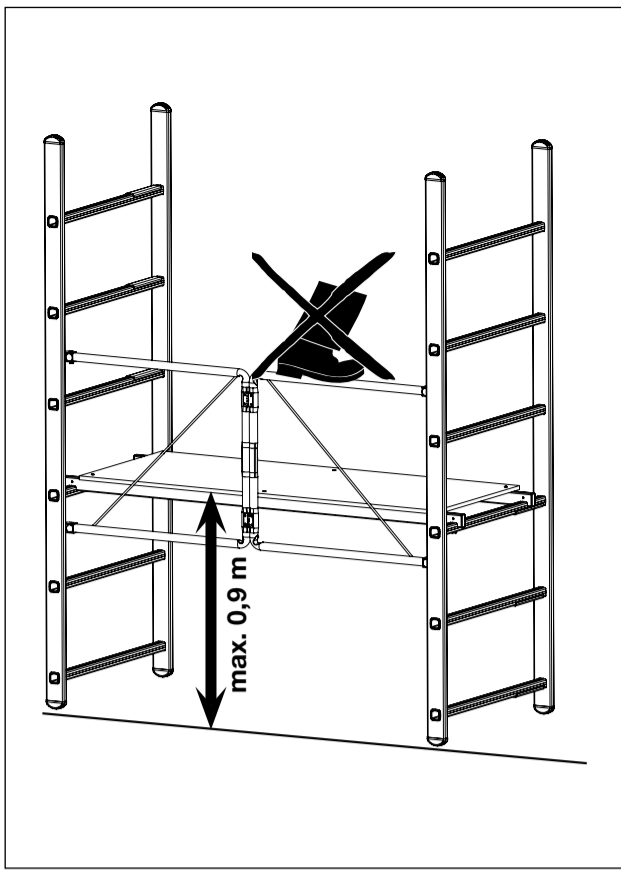

- | | | | | | | | | |
|---|---|--|---|--|--|--|---|---|
| 1. Schadhafte Gerüstteile sind unverzüglich auszutauschen. | 1. Damaged scaffold parts must be withdrawn from circulation immediately. | 1. Si votre article est endommagé, veuillez ne plus l'utiliser. | 1. Las piezas dañadas hay que intercambiarlas de inmediato. | 1. Defekte stiger und defekte dele til stiger skal udskiftes straks. | 1. Sérült állványelemeket azonnal ki kell cserélni. | 1. Uszkodzone elementy ruszowań należy natychmiast wymienić na nowe. | 1. По повреждённым элементам строительных лесов надлежит незамедлительно заменить на новые. | 1. Poškozené žebříky vyřadit z oběhu. |
| 2. Für unsachgemäße Behandlung wird keine Haftung übernommen. | 2. No liability for improper use. | 2. Toute utilisation non-conforme n'est effectuée sous garantie. | 2. En caso de un tratamiento inadecuado no nos haremos cargo. | 2. Intet erstatningsansvar ved forkert anvendelse. | 2. Szakszerűlen kezelésért nem vállalunk felelősséget. | 2. Za użytkowanie niezgodne z przeznaczeniem nie ponosimy odpowiedzialności. | 2. За использование несоответственно с назначением ответственности не несём. | 2. Neneseme odpovědnost za nesprávné použití. |
| 3. Nur original Ersatzteile verwenden. | 3. Only use original accessories. | 3. Seulement utilisation de pièces d'origine. | 3. Utilizar solo piezas de recambio originales. | 3. Kun original tilbehør må anvendes. | 3. Csak eredeti pótalkatrész használható fel. | 3. Używać tylko oryginalnych części zamiennych. | 3. Использовать только оригинальные запчасти. | 3. Používat pouze originální části Krause. |
4. Lešení je určeno do interiéru s vyloučenou prací v horizontálním směru (tj. vrtnání, bourací práce apod), viz ČSN 73 8102

