

SOJAG

produits saisonniers • seasonal products



Sojag code: 999-7160505

CUP/UPC code: 772830160505

Assembly Manual / Guide d'assemblage / Manual de ensamblaje / 조립 설명서 / Montageanleitung

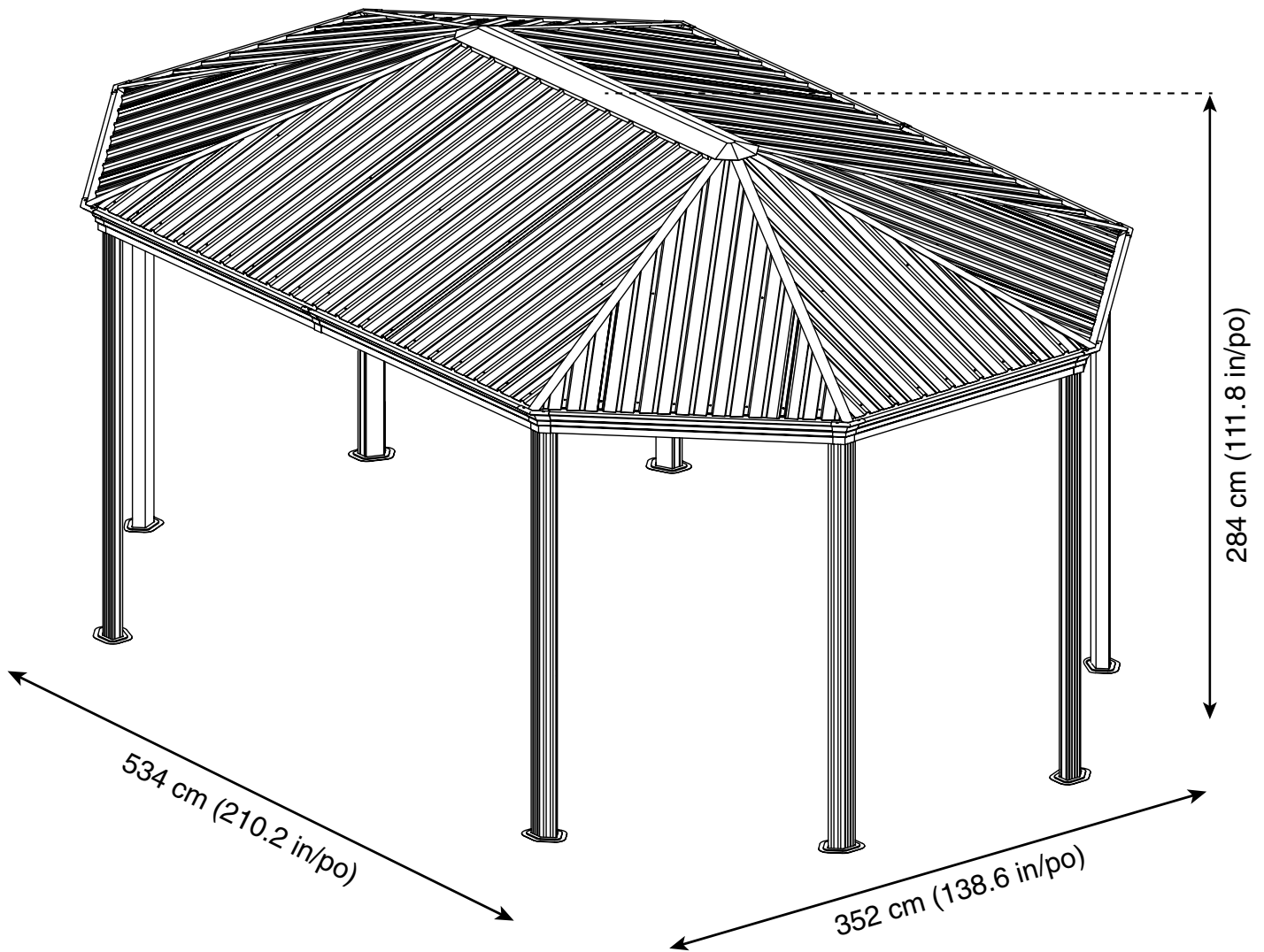

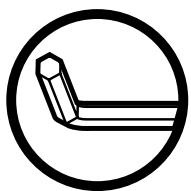

Use the hex keys in the box. / Utilisez les clés hexagonales fournies dans la boîte. / Utilice las llaves hexagonales en la caja. / 상자에 육각 키를 사용 하십시오. / Verwenden Sie die Sechskantschlüssel in der Box.

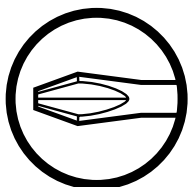

Please use a Phillips screwdriver. / Utilisez un tournevis de type Phillips / Por favor, use un destornillador Phillips. / 십자 드라이버를 사용 하십시오. / Bitte verwenden Sie einen Kreuzschraubenzieher.

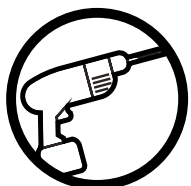

You may need to use a drill for this step. / Vous pouvez avoir besoin d'utiliser une perceuse pour cette étape. / Puede que tenga que utilizar un taladro para este paso. / 이 단계에선 드릴을 사용해야 할 수도 있습니다. / Für diesen Schritt können Sie einen Bohrer verwenden.



Wearing protective gloves is recommended. / Le port de gants de protection est recommandé / El uso de guantes de protección se recomienda. / 보호 장갑을 착용 하는 것이 좋습니다. / Das Tragen von Schutzhandschuhen wird empfohlen.



Two or more people are required at this stage. / Deux personnes ou plus sont nécessaires à cette étape. / Dos o más personas se requieren en esta etapa. / 이 단계에서는 두 명 이상이 필요합니다. / Für diesen Bauschritt sind 2 oder mehr Personen erforderlich.

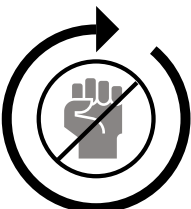

Do not tighten screws all the way for now. / Ne pas visser fermement pour l'instant. / No atornille con firmeza por ahora. / 아직 나사를 단단히 조이지 마십시오. / Bitte die Schrauben zum jetzigen Zeitpunkt noch nicht fest anziehen.

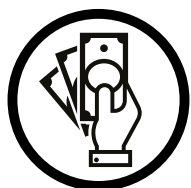

Sold separately. / Vendus séparément. / vendido en las opciones. / 옵션 판매 / Optional erhältlich

S X 20 (+2)

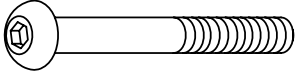

T X 84 (+8)



Wa X 2



U X 3 (+1)

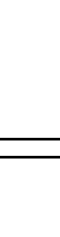

V X 144 (+10)



W2 X 1



X X 16 (+2)

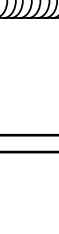

X1 X 2 (+1)

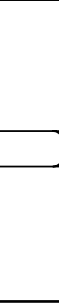

Y X 116 (+10)







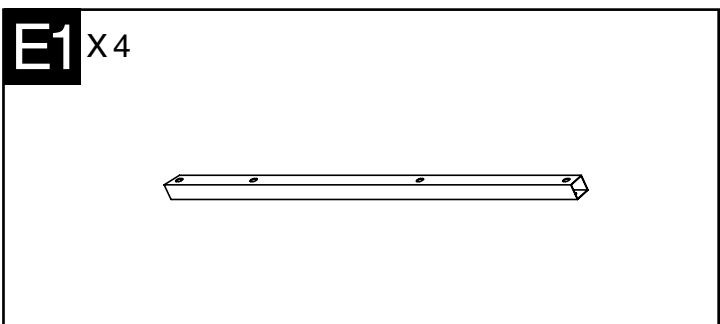
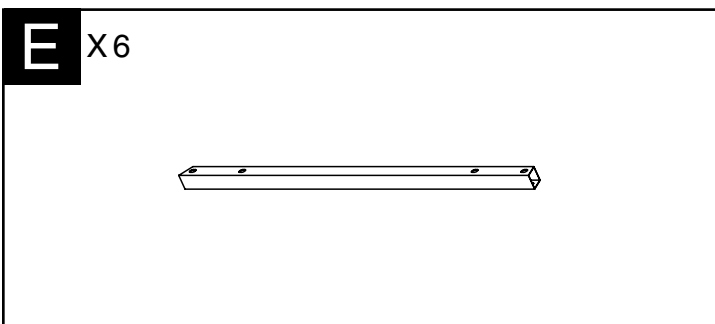
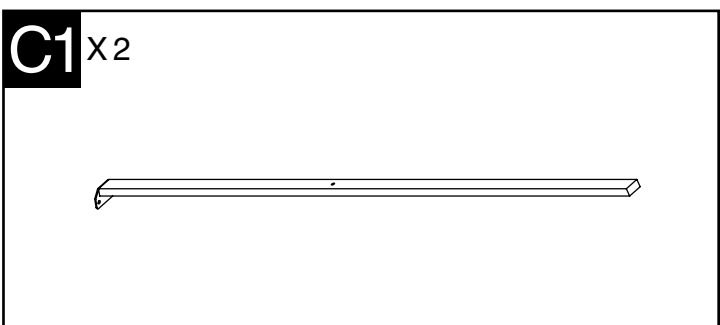
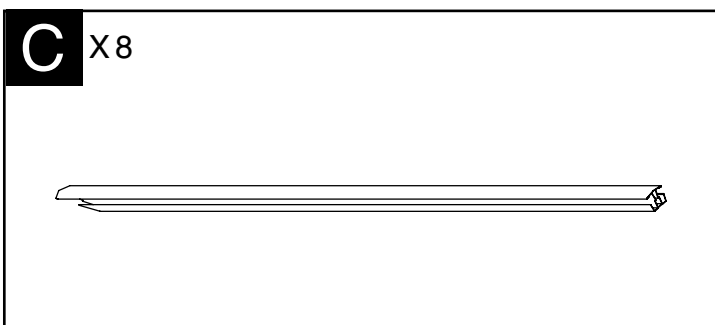
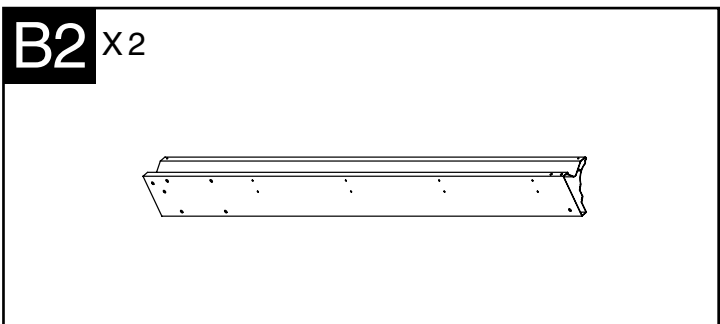
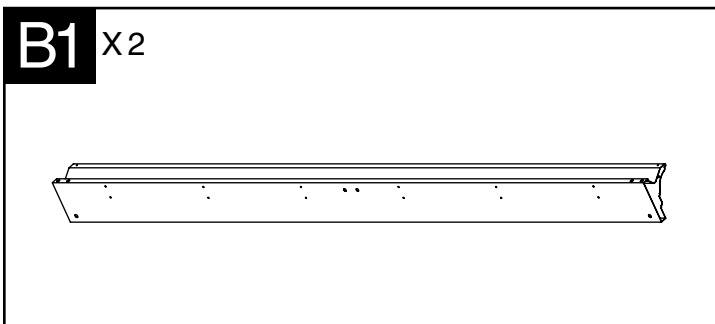
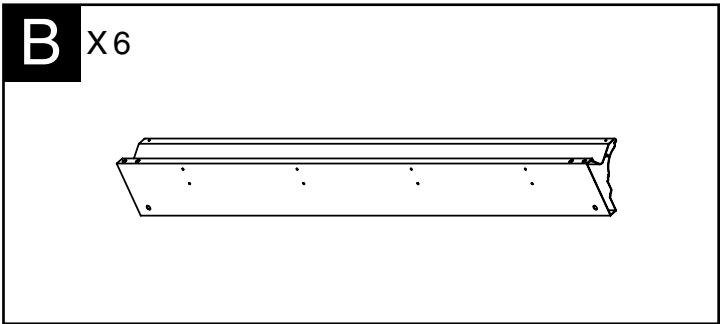
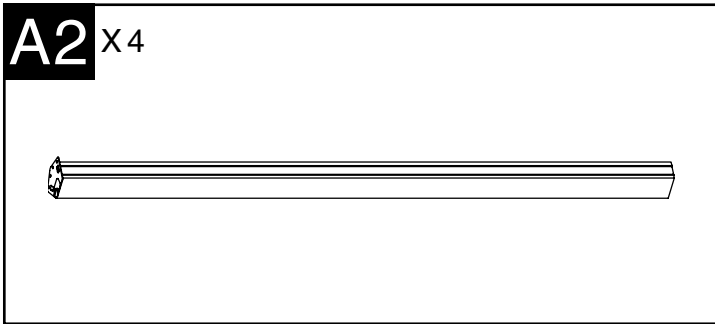
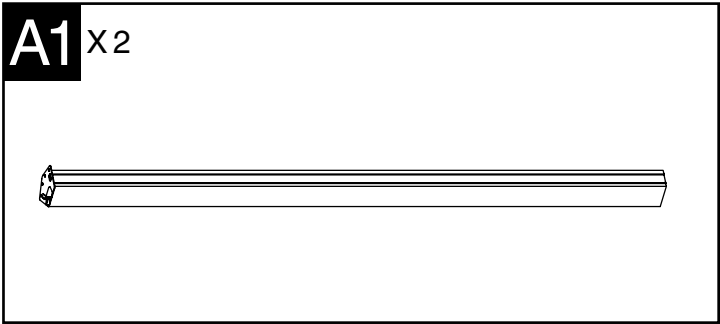
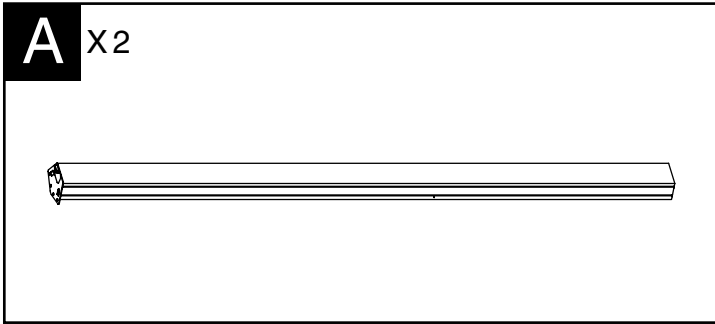

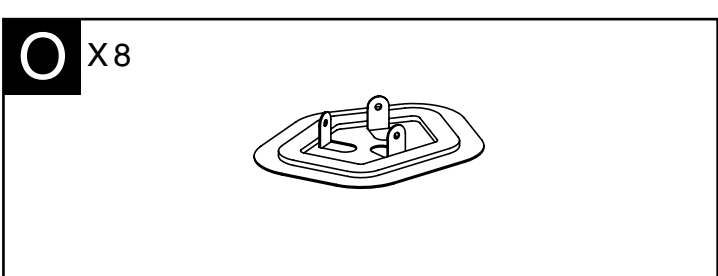
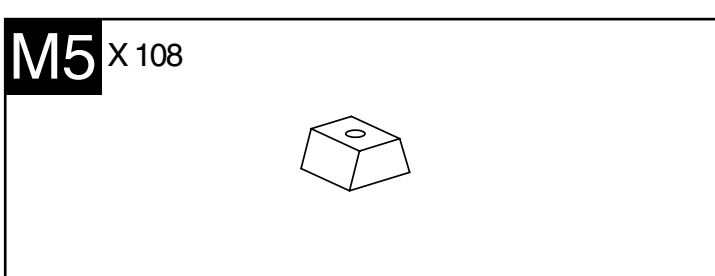
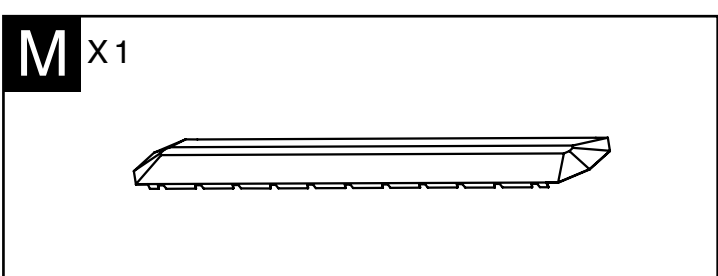
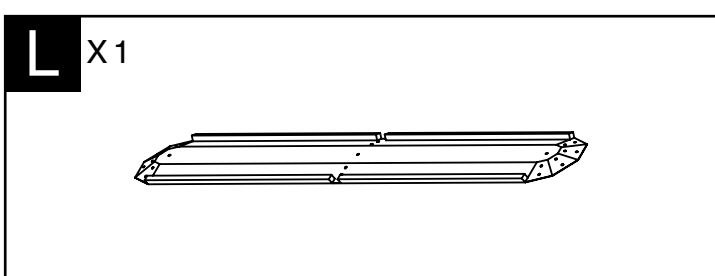
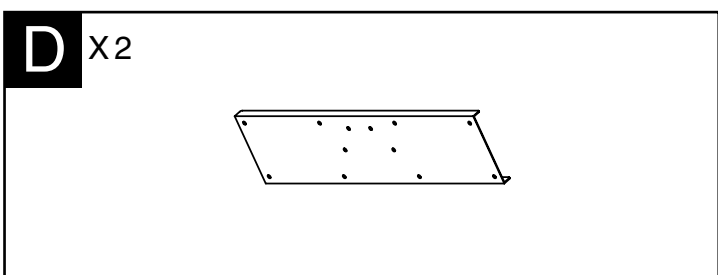
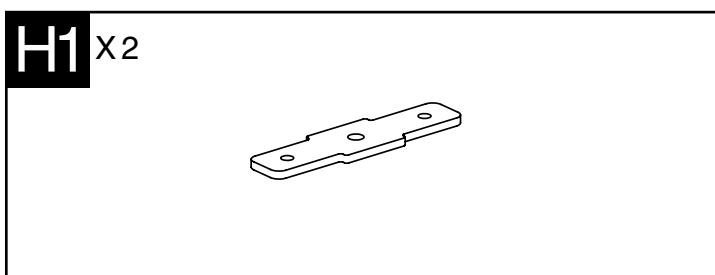
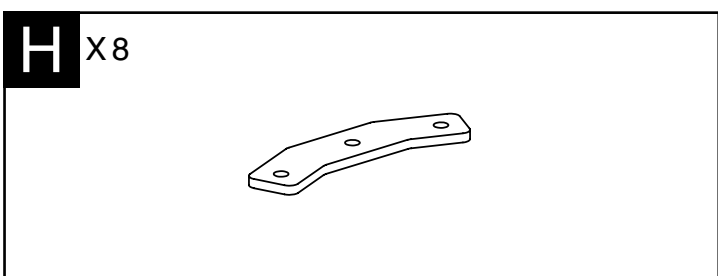
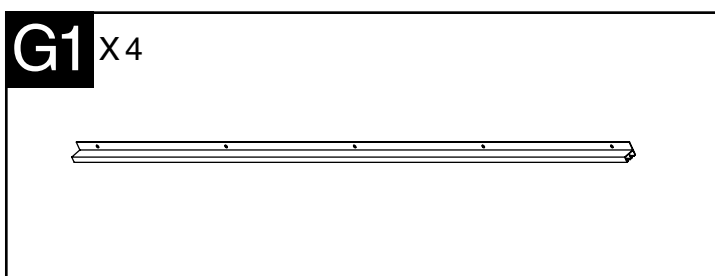
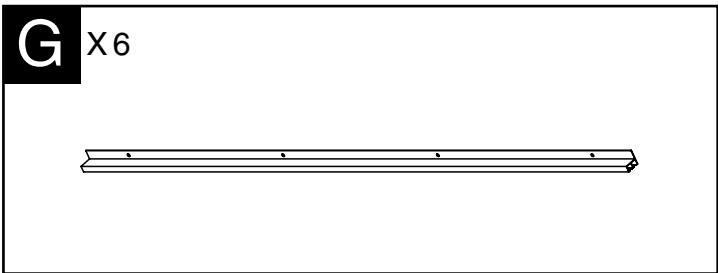
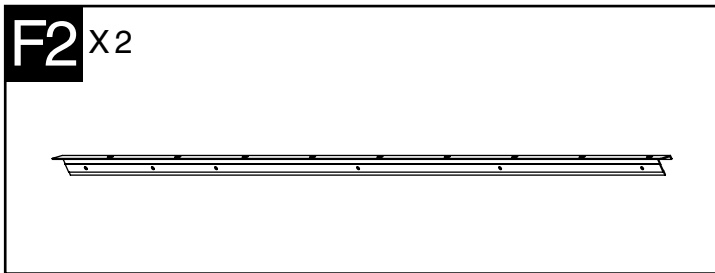
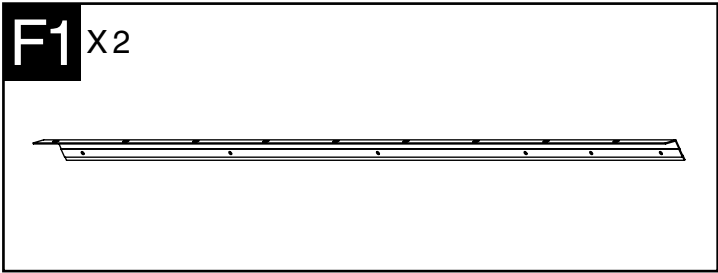
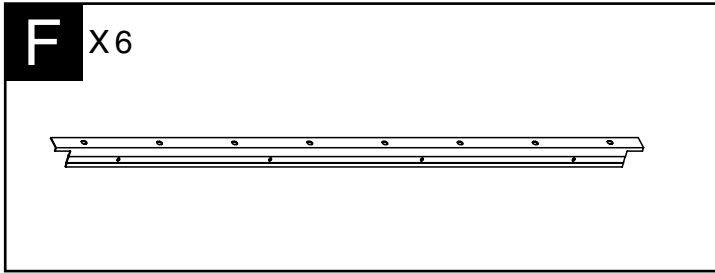

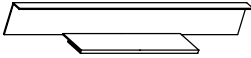
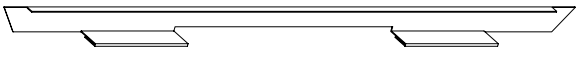



Z X 2

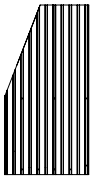
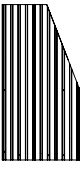

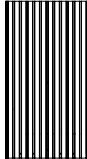
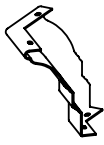
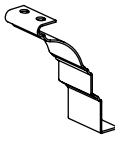
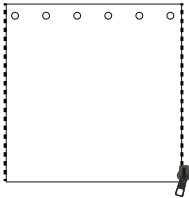

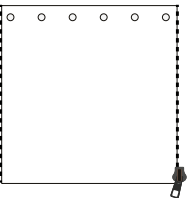

D2 X 12 	D3 X 48 
D4 X 8 	R X 12 
K1 X 6 	K2 X 6 
K3 X 6 	N1 X 2 
N2 X 2 	N3 X 2 
N4 X 2 	N5 X 2 
P X 8 	P1 X 2 
Mo X 4  Q X 56  	Ca X 4  Q X 56  

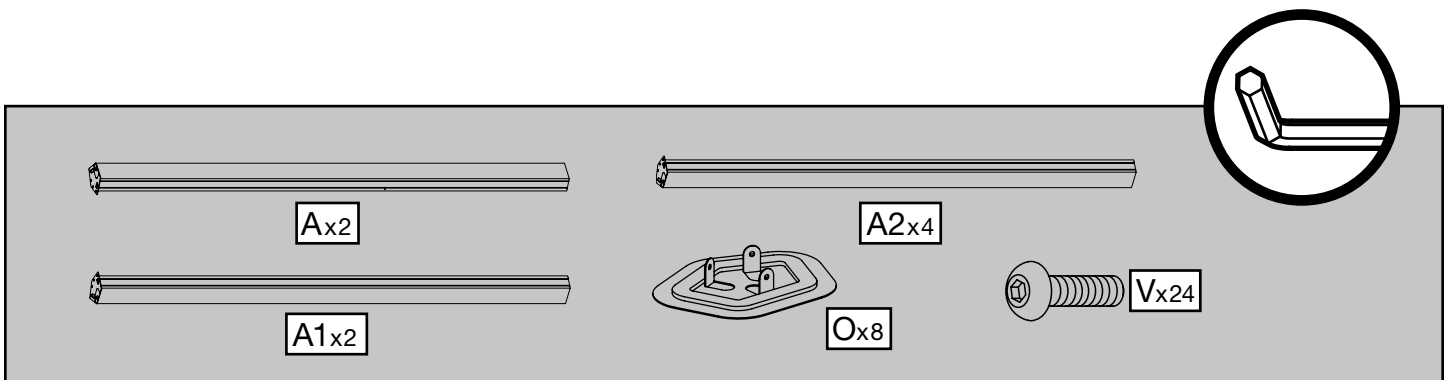
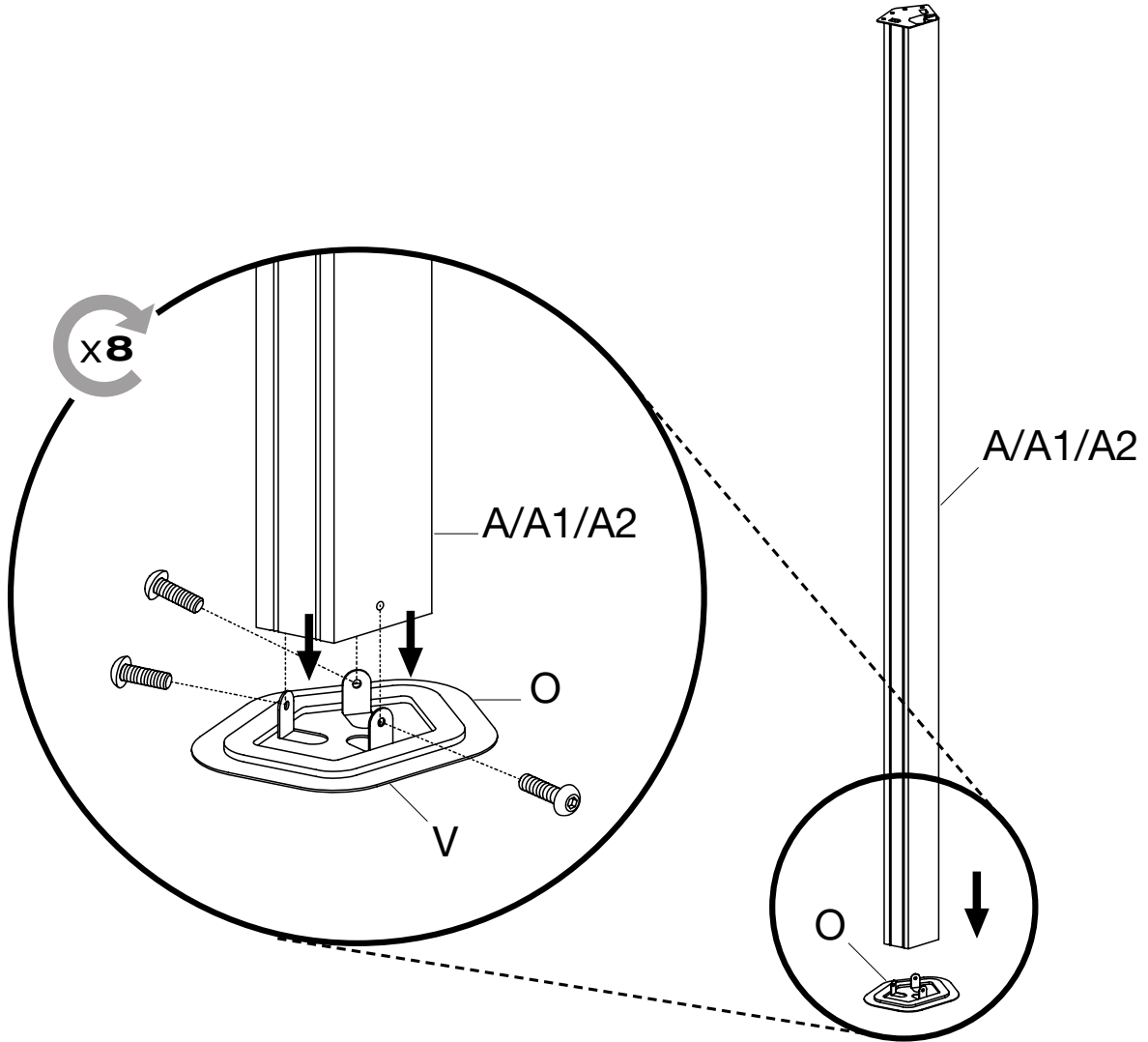

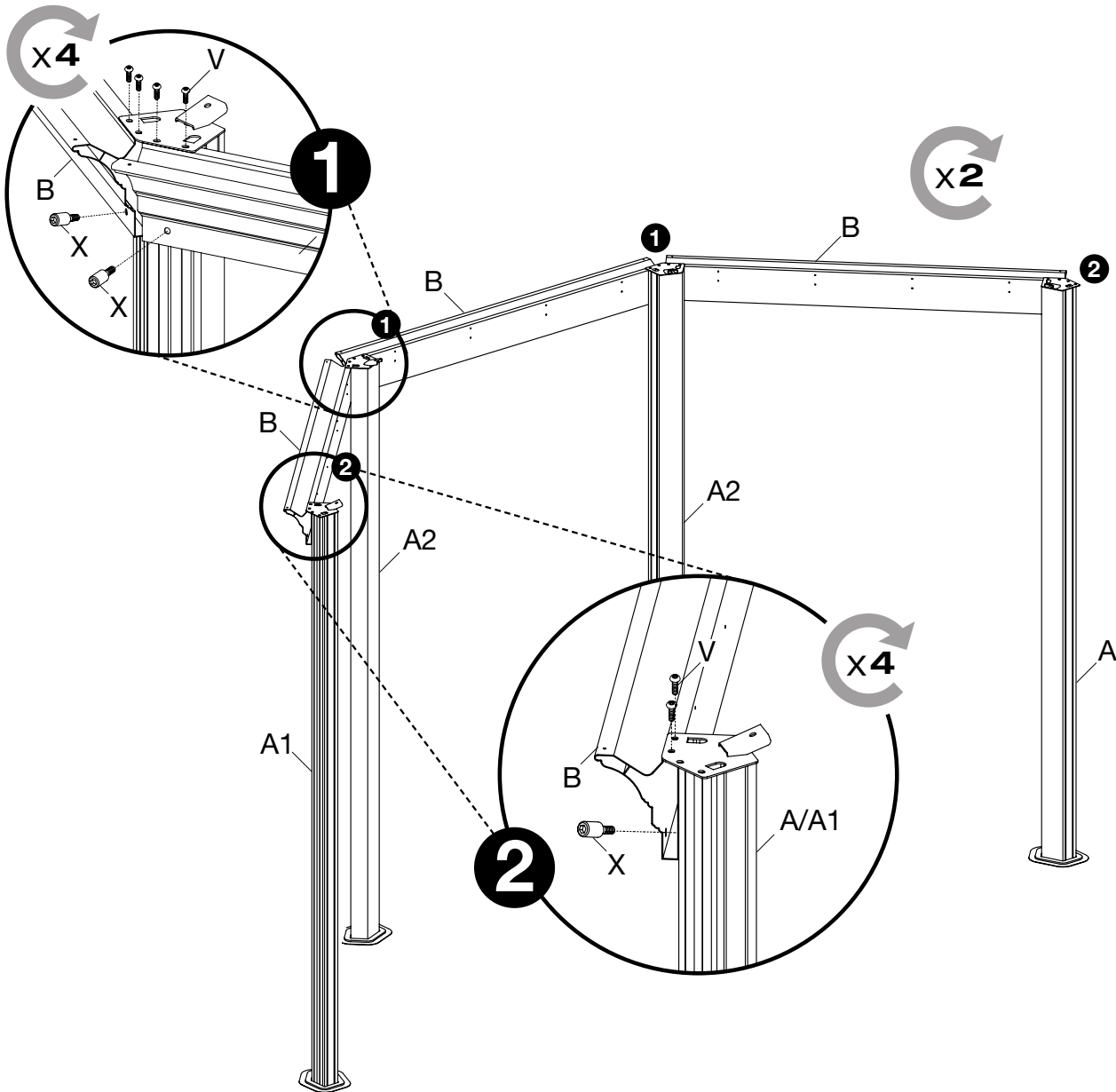

Bx6 **Xx12** **Vx24**

2+

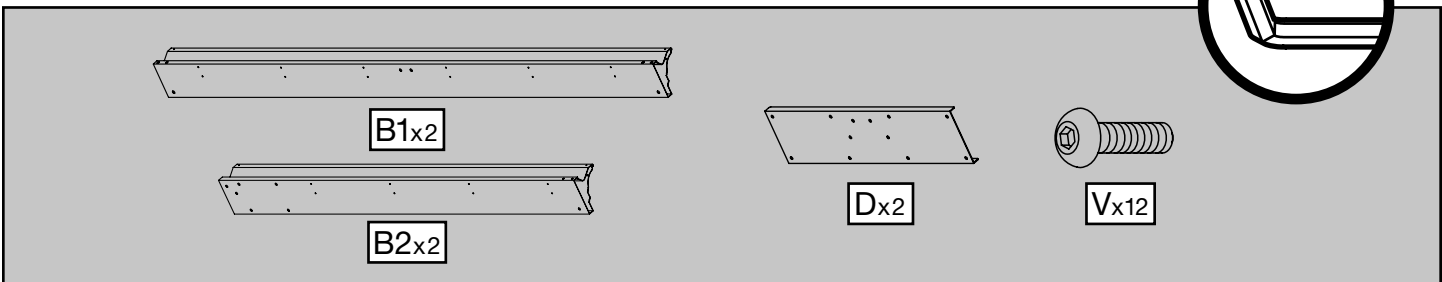
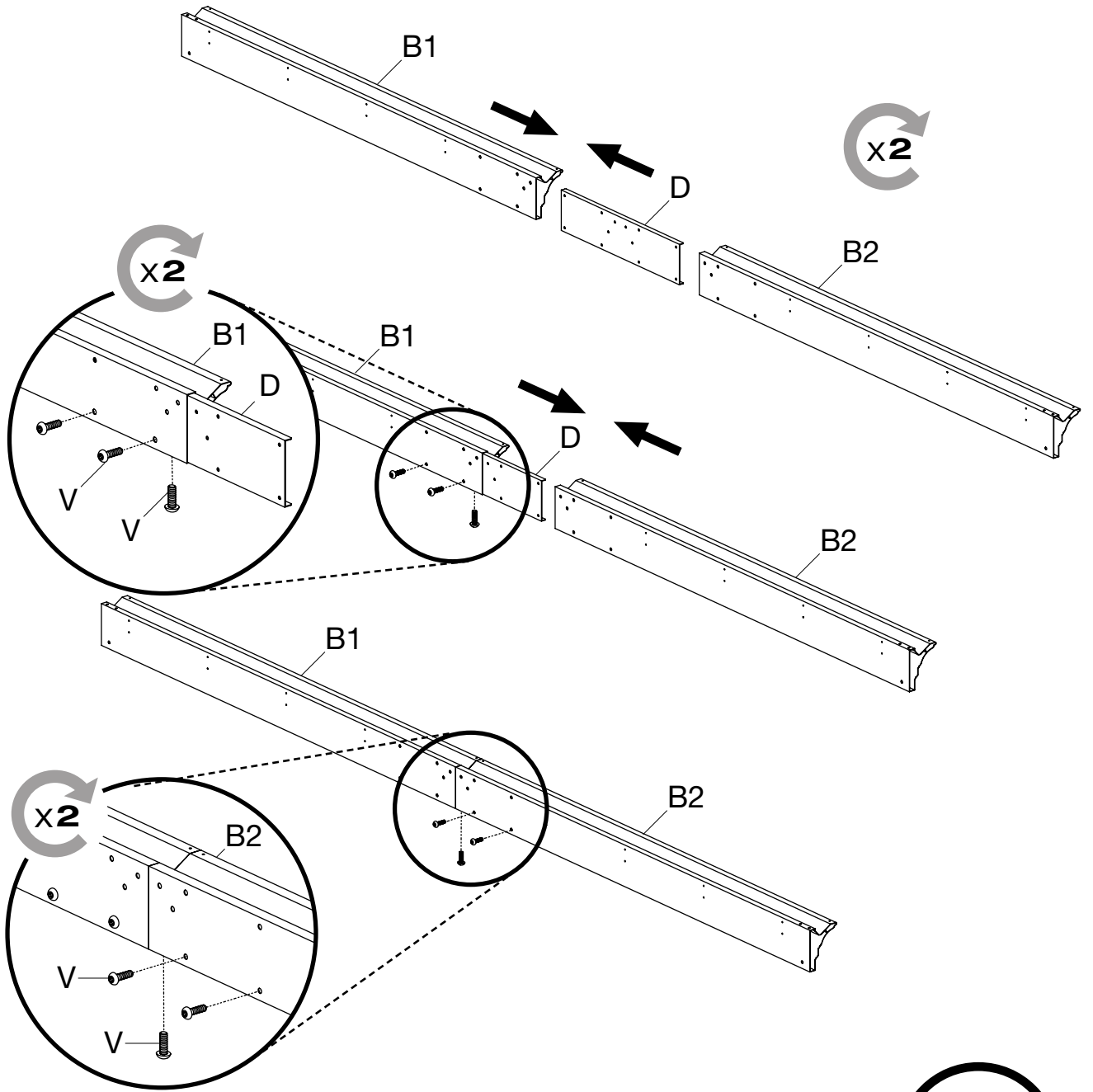

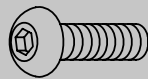
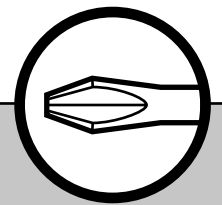
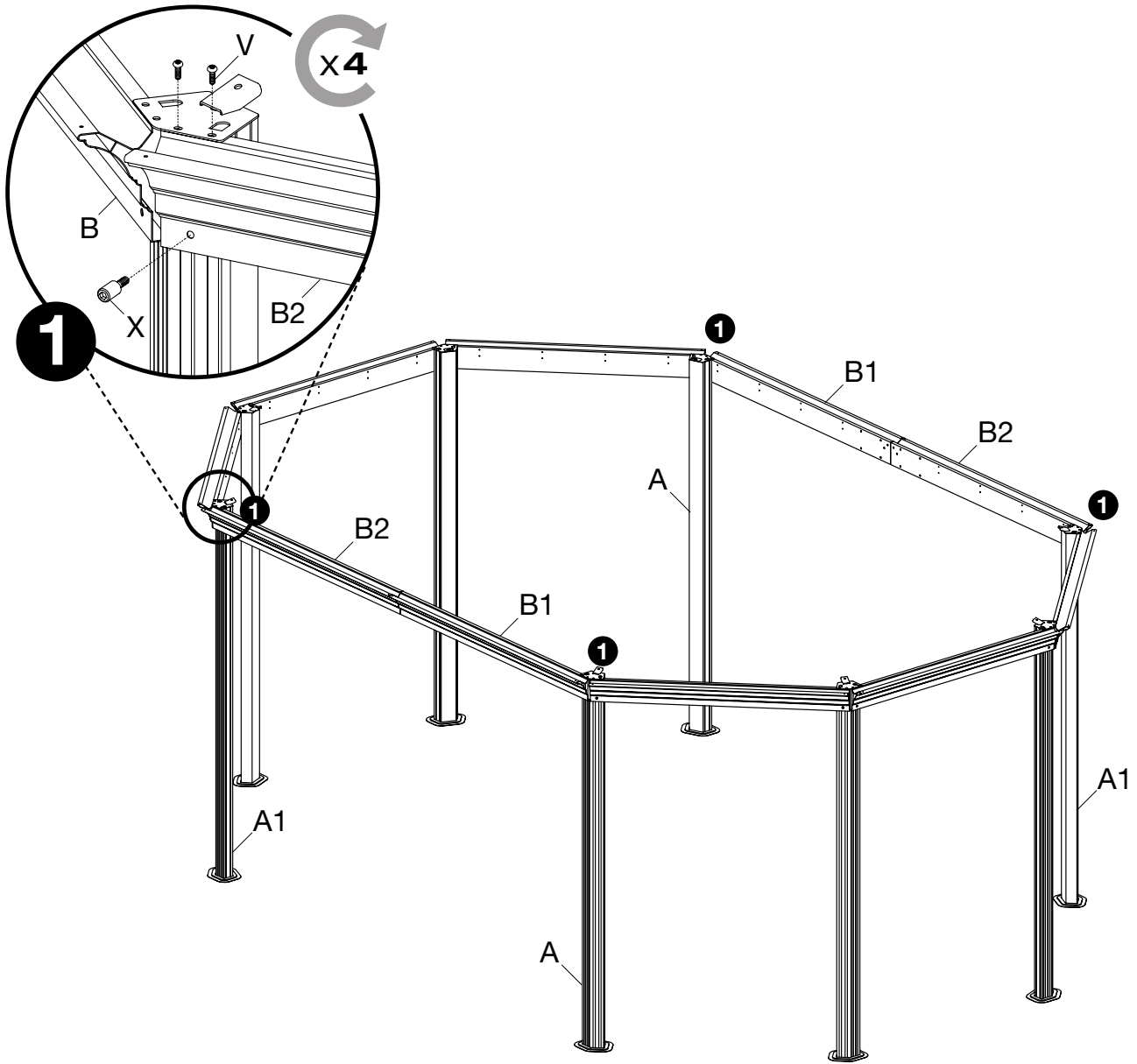

Vx8

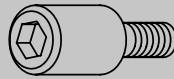

Xx4

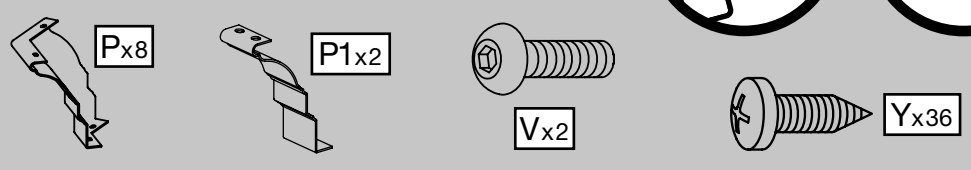
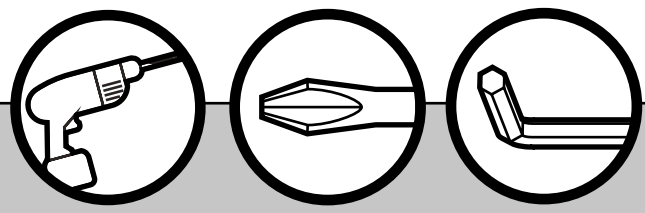
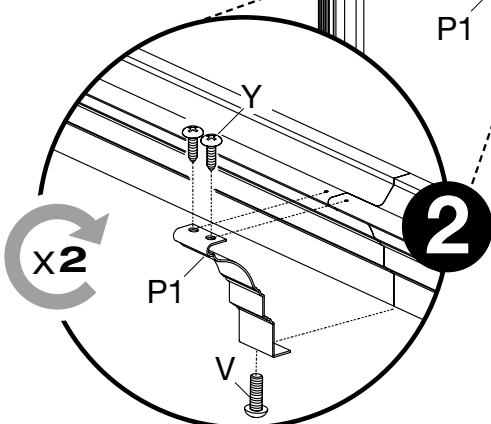
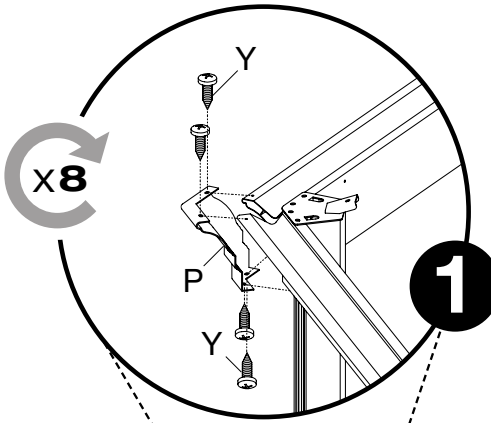
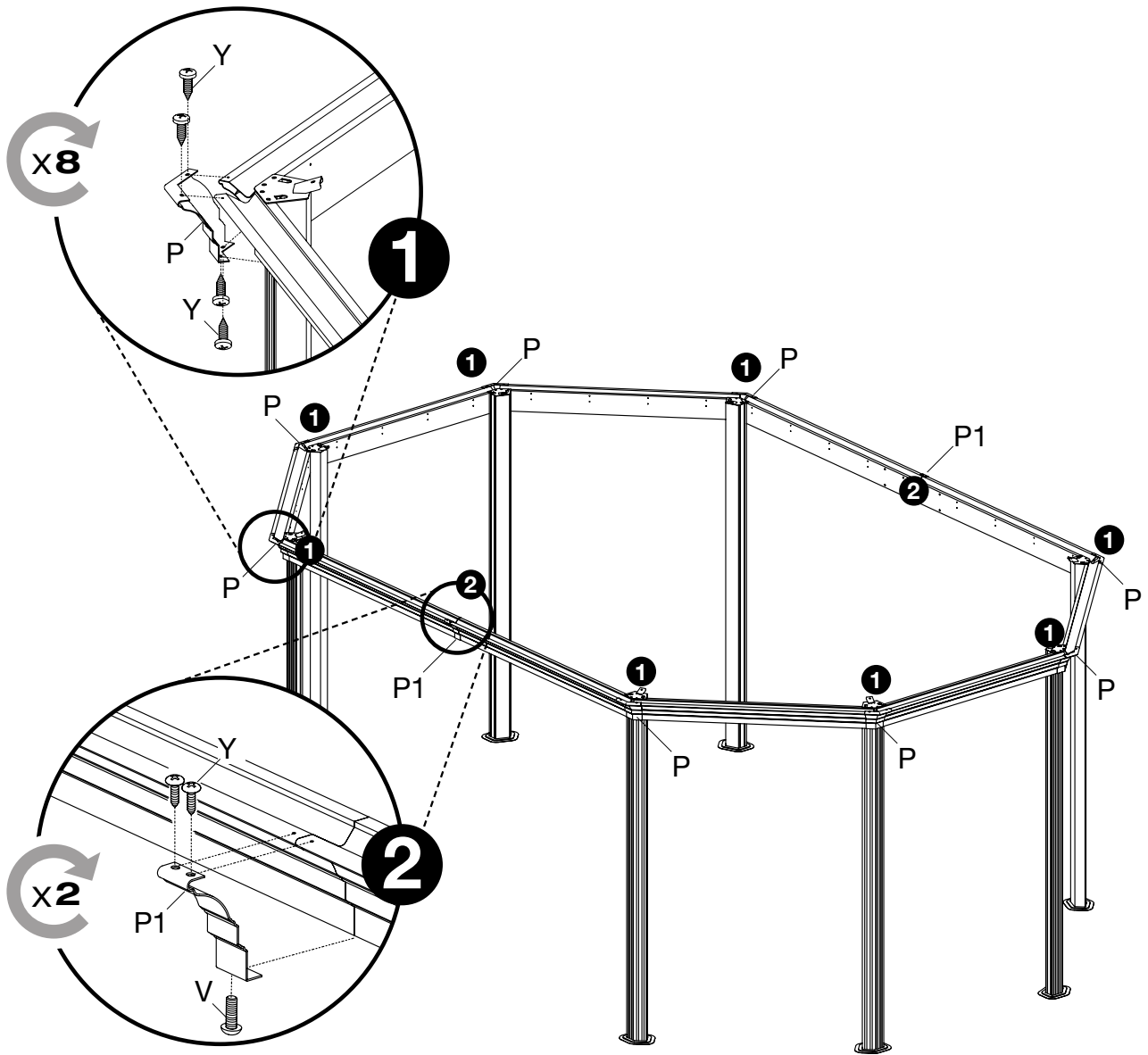

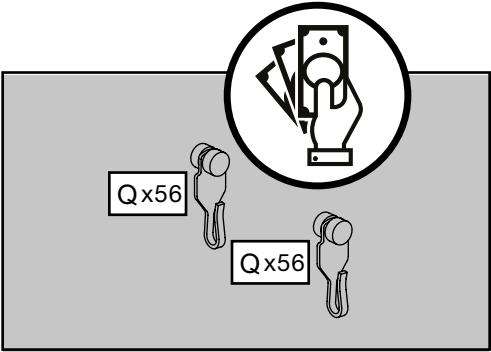
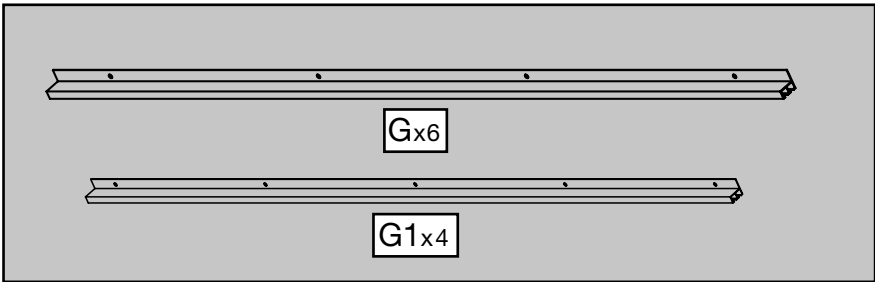
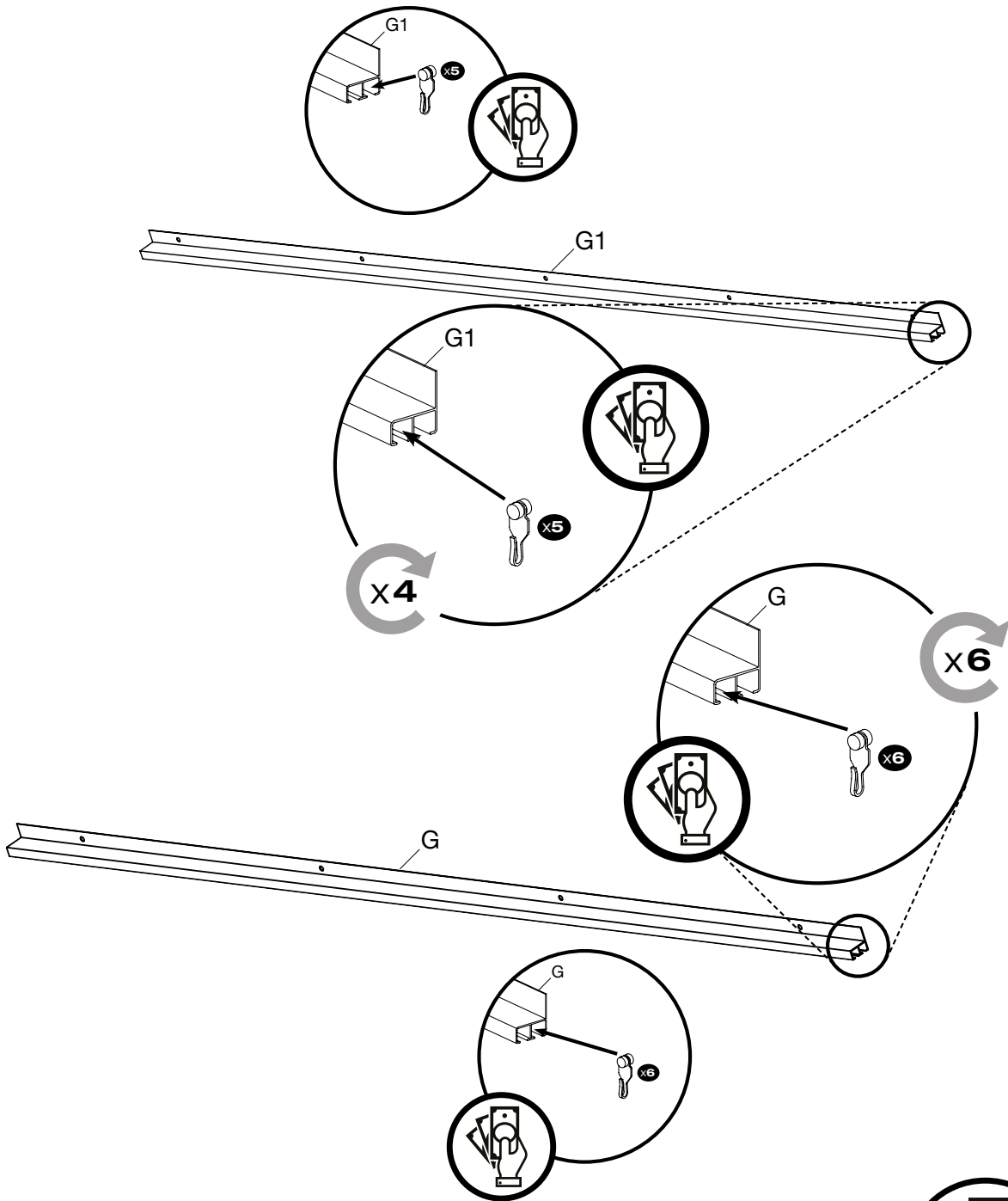

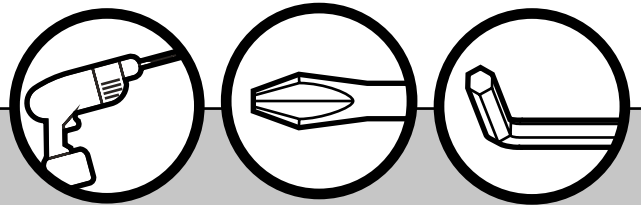
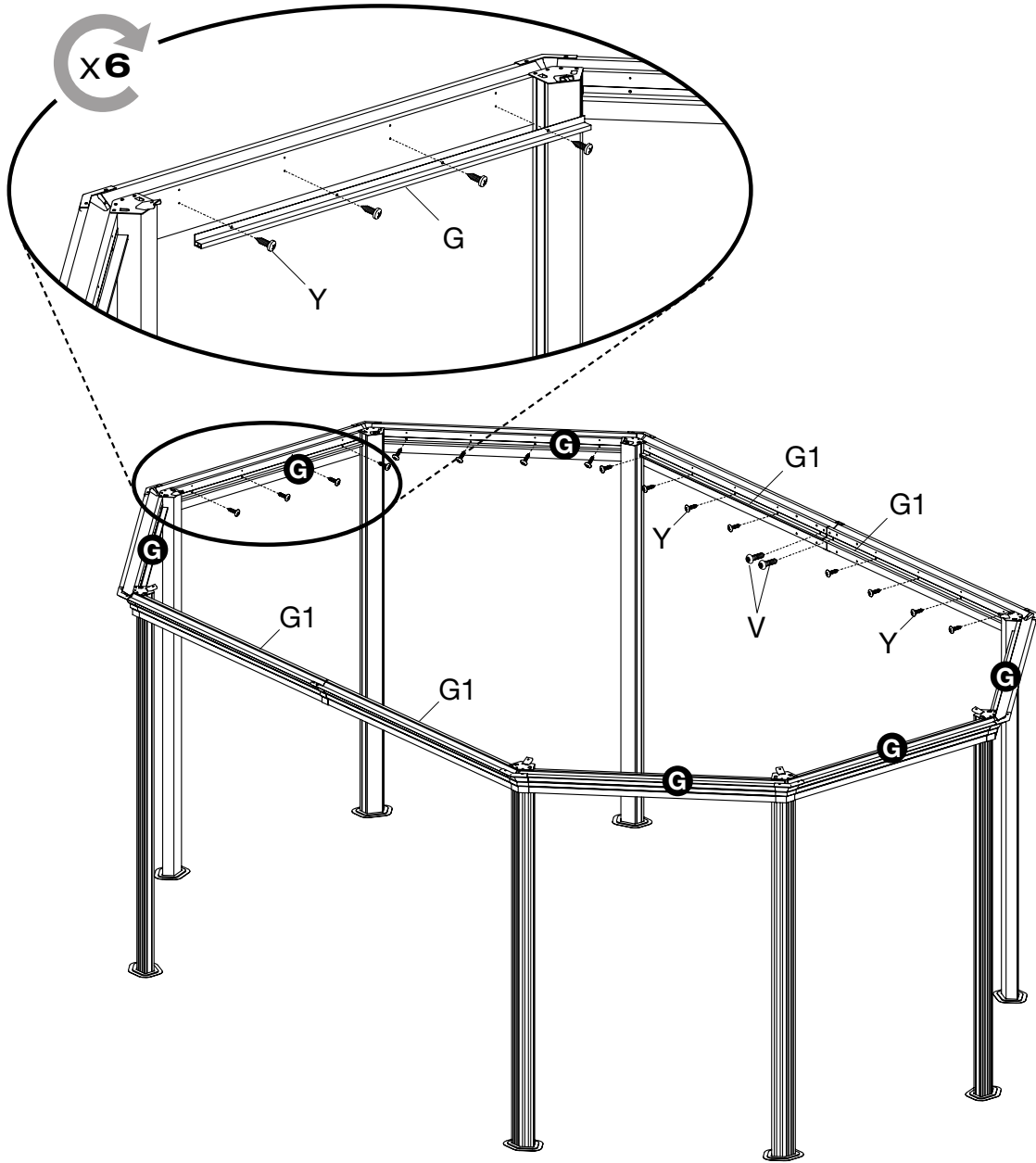

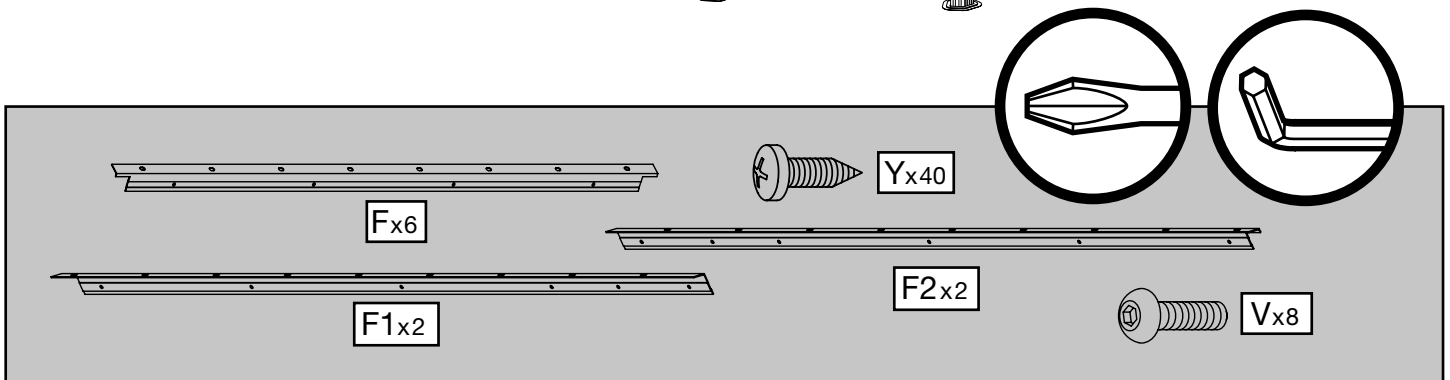
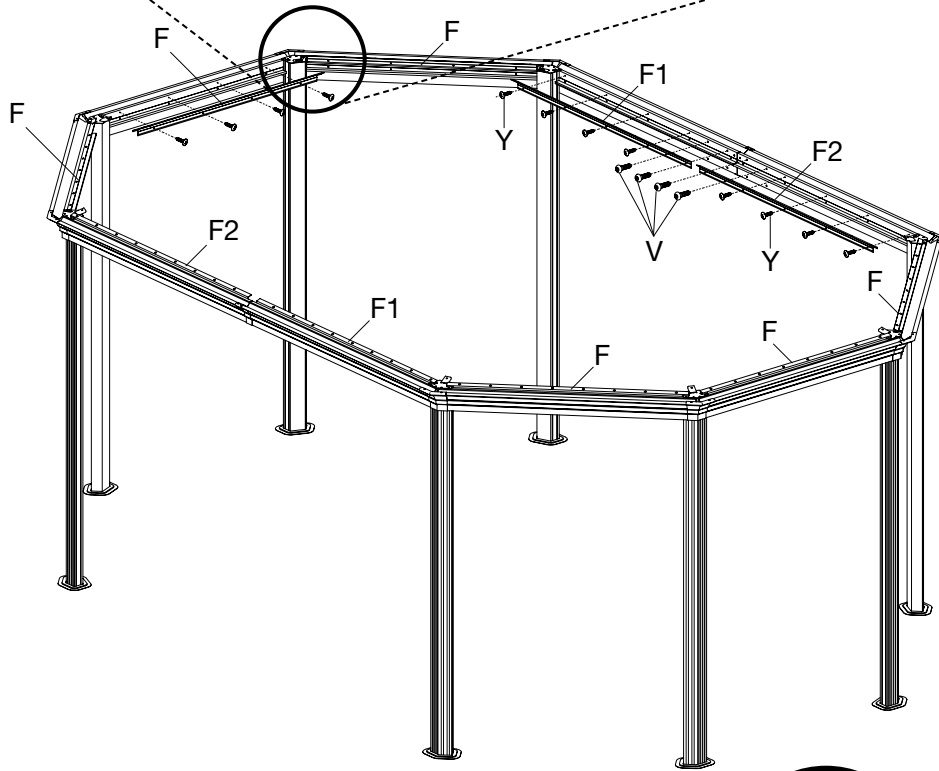
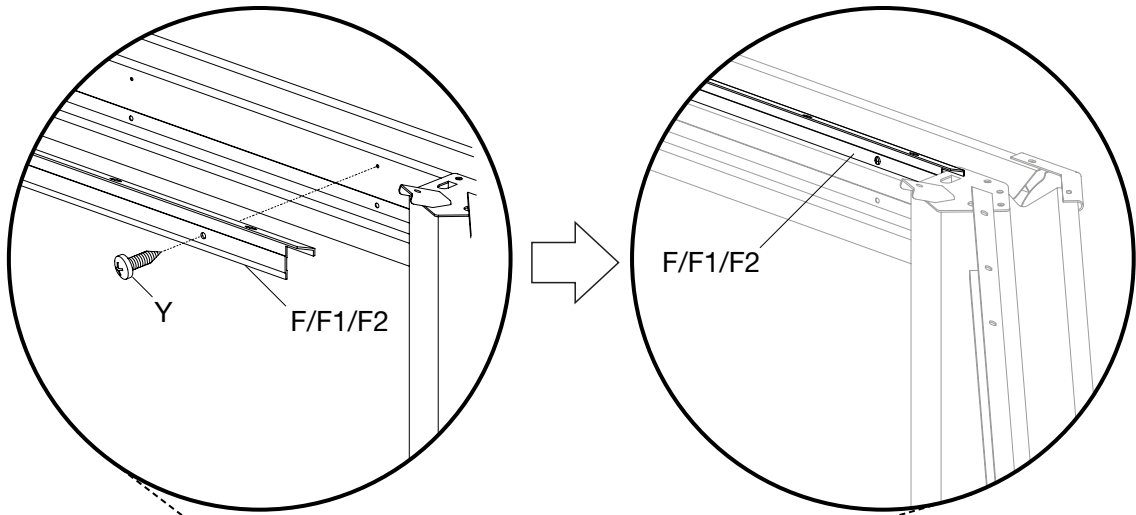

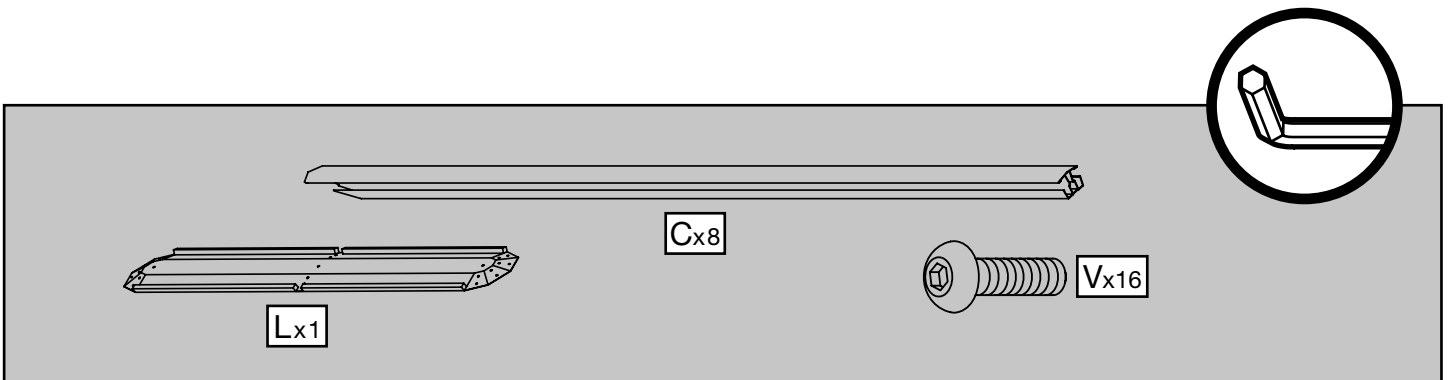
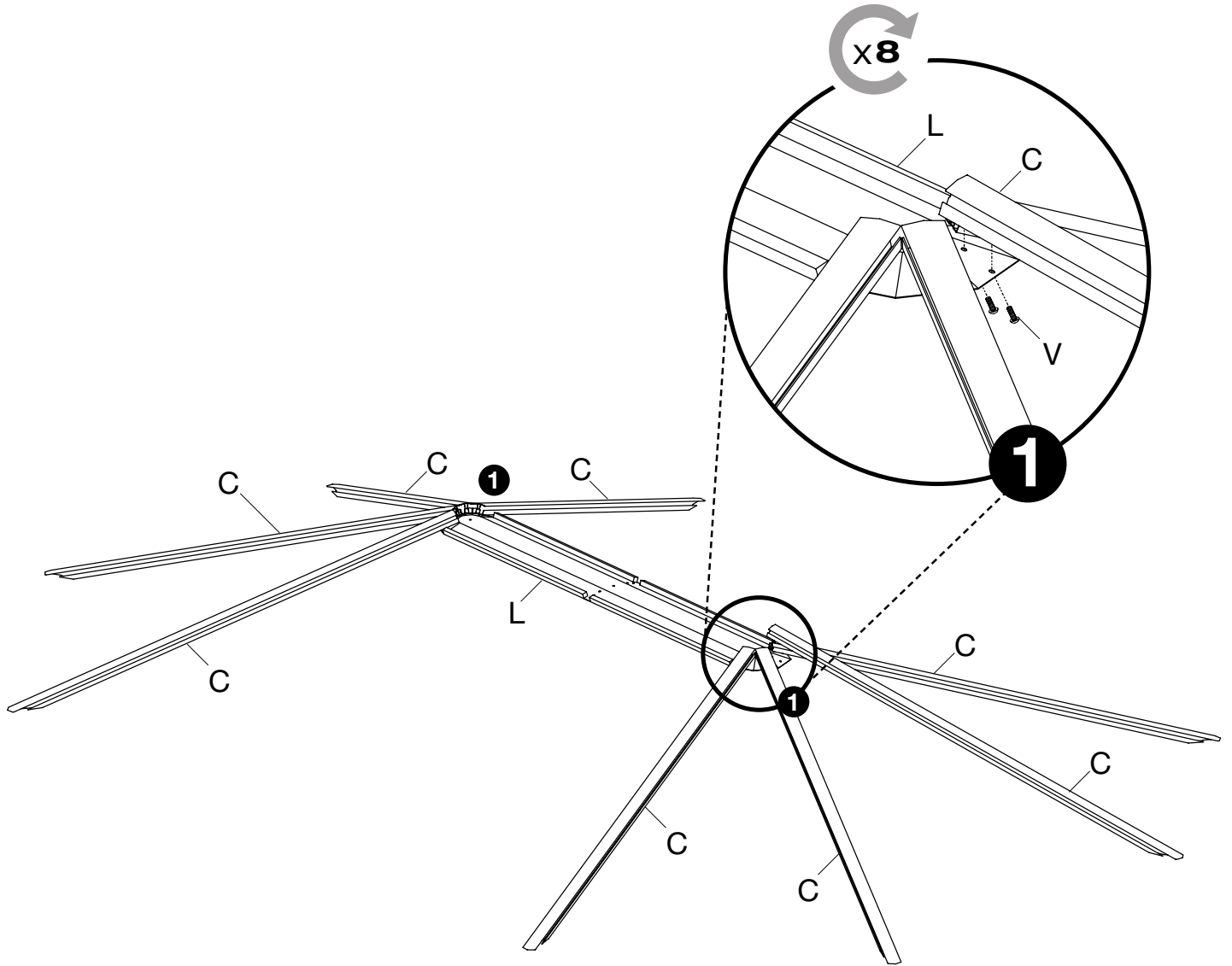

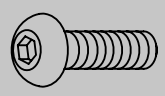
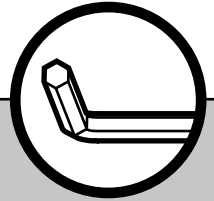
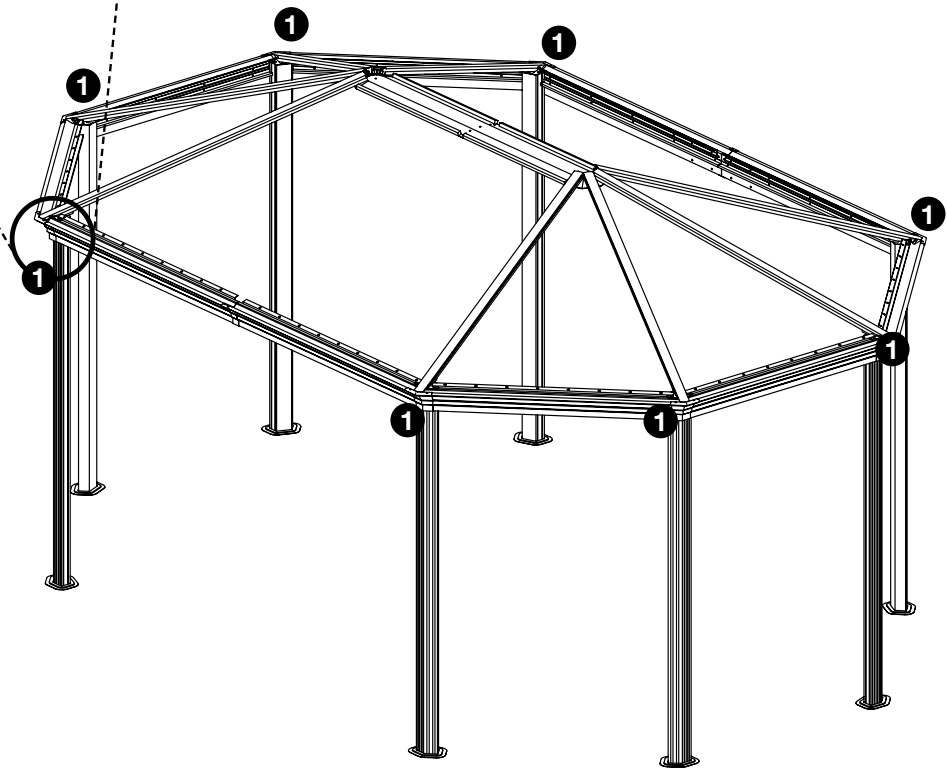
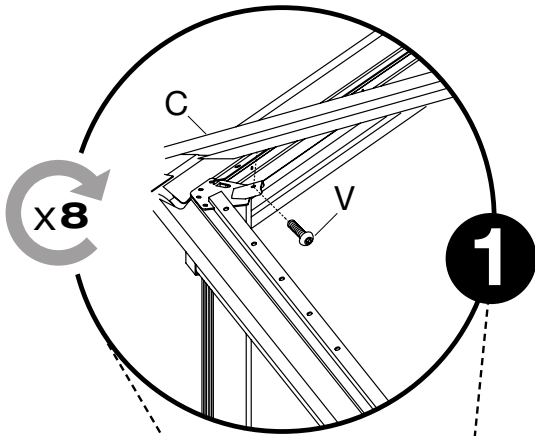

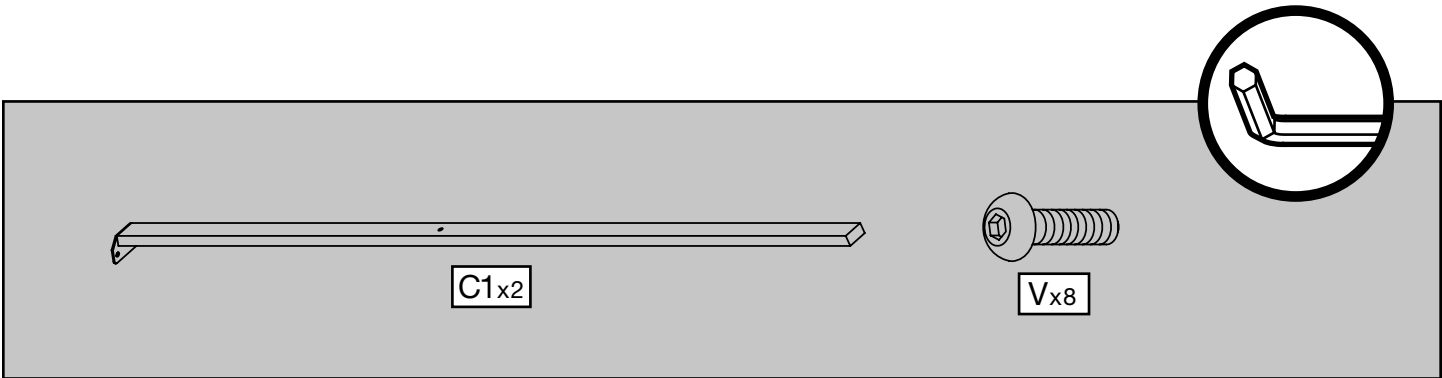
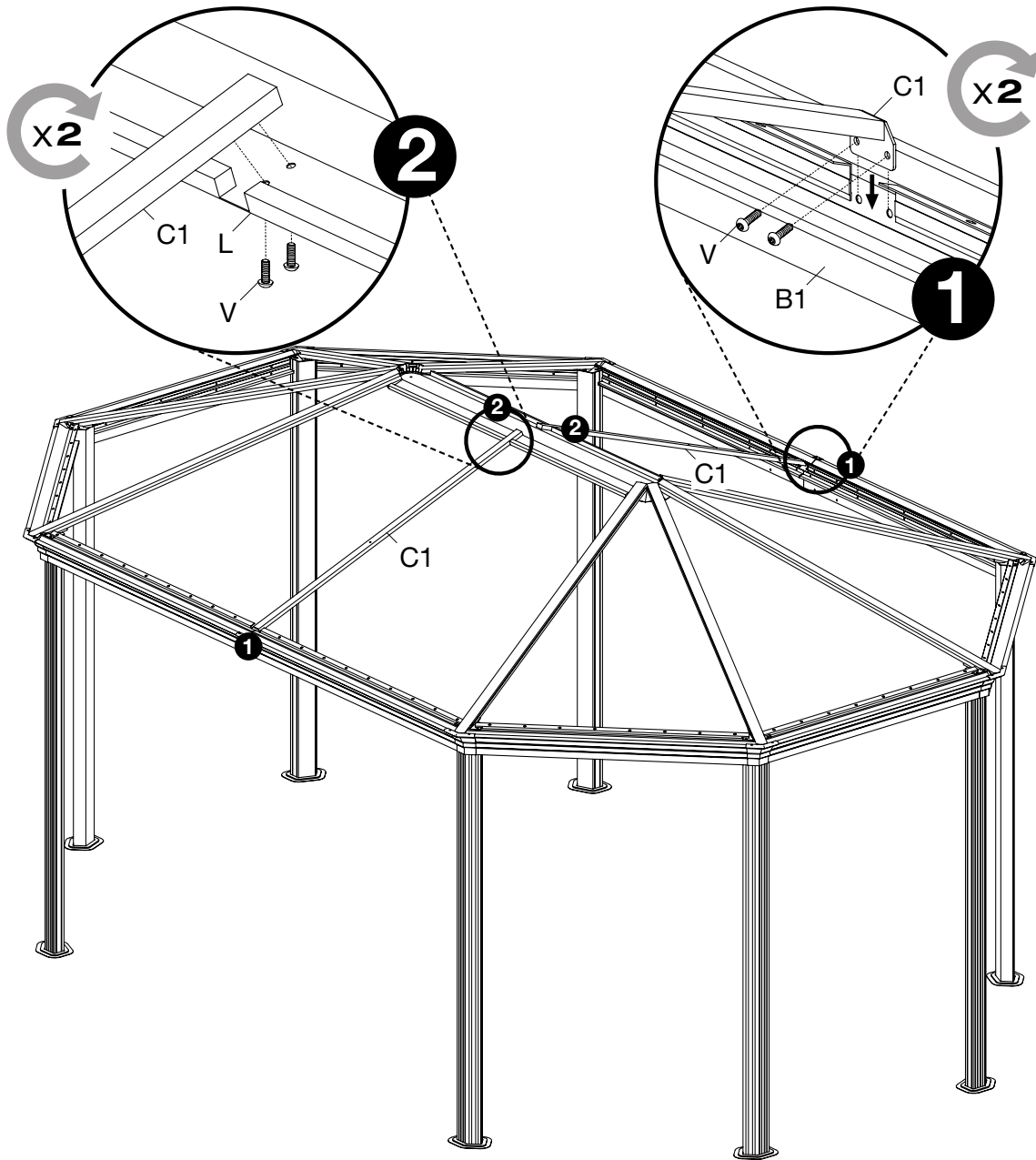

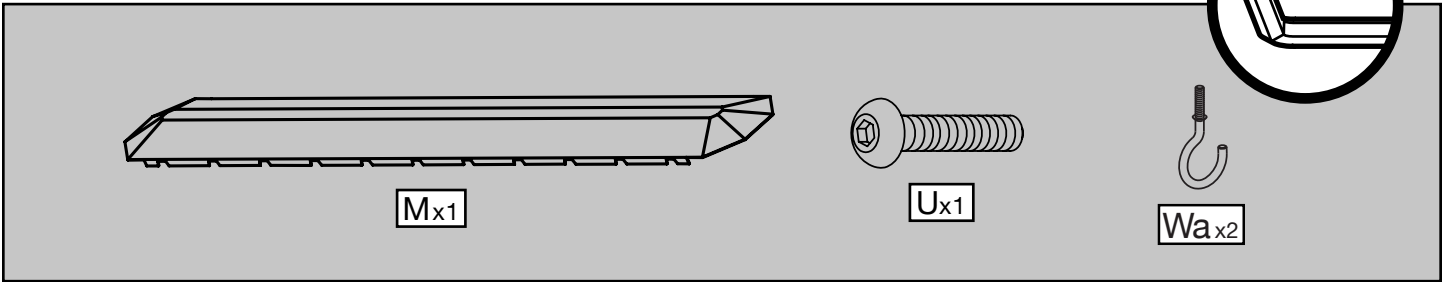
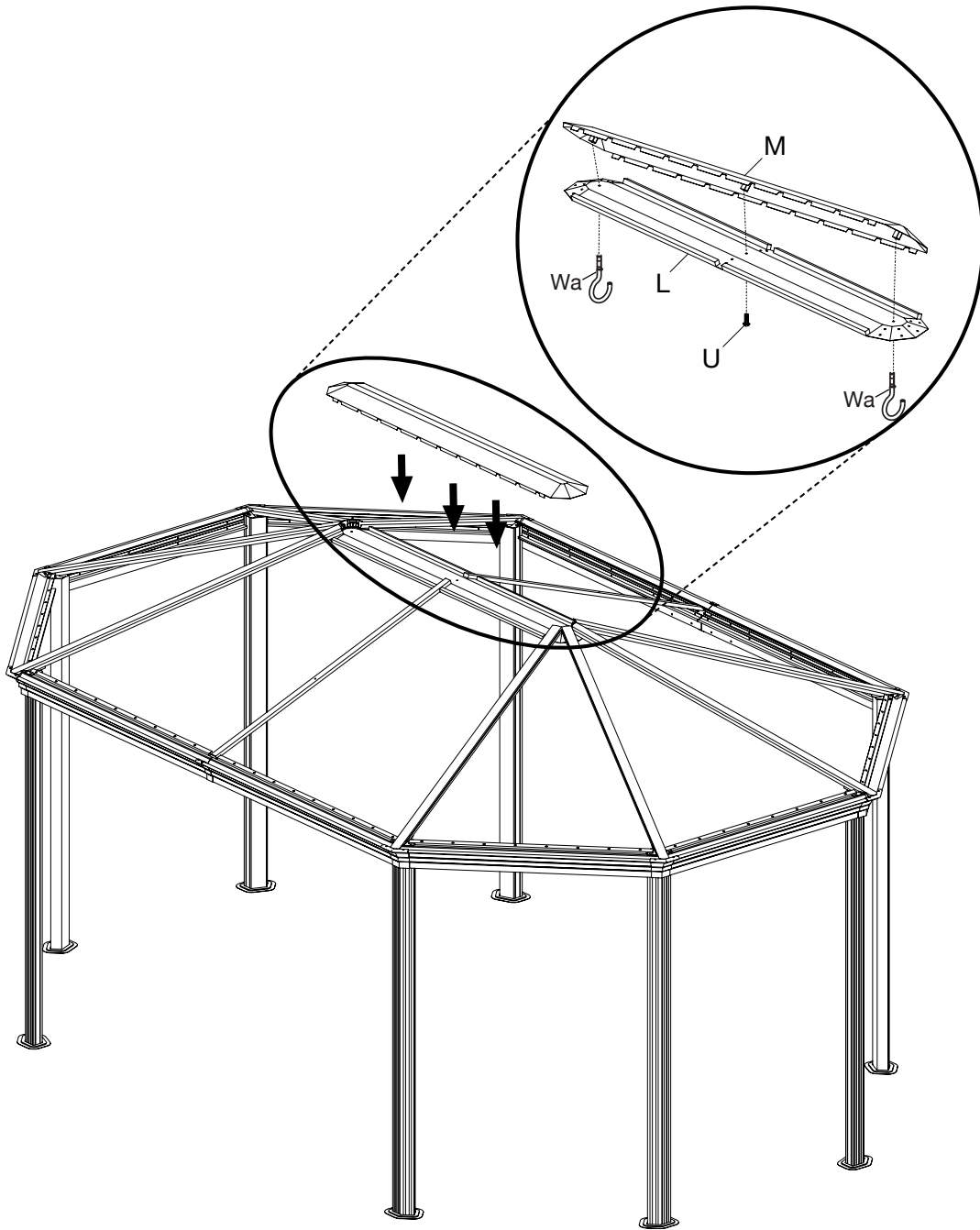

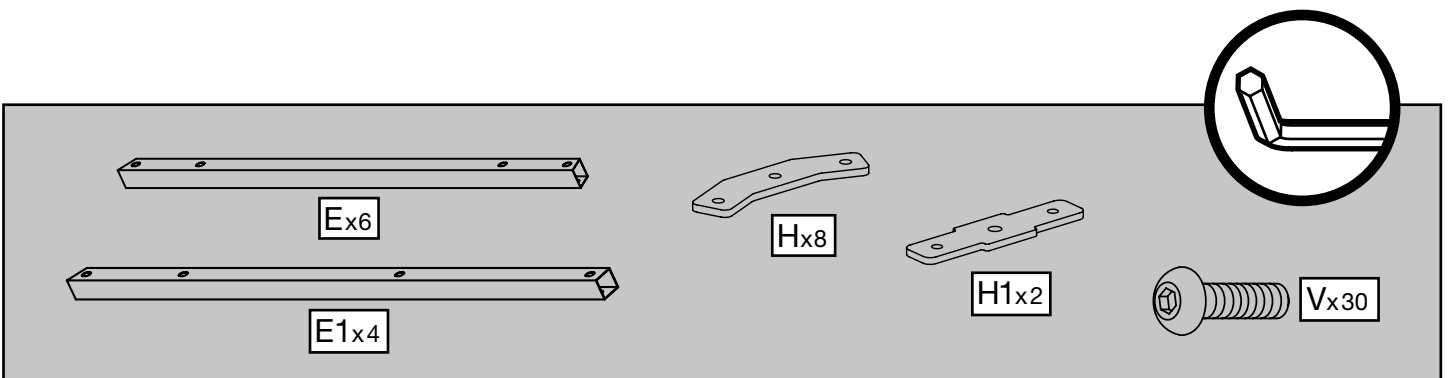
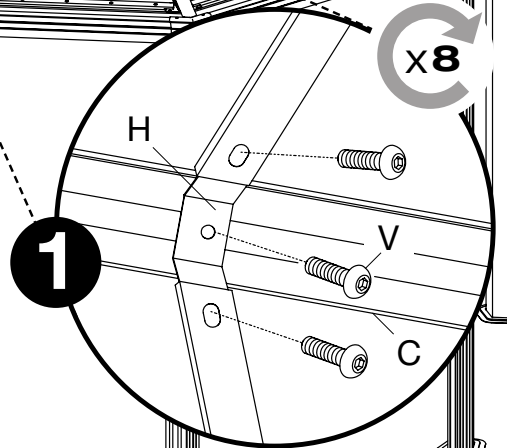
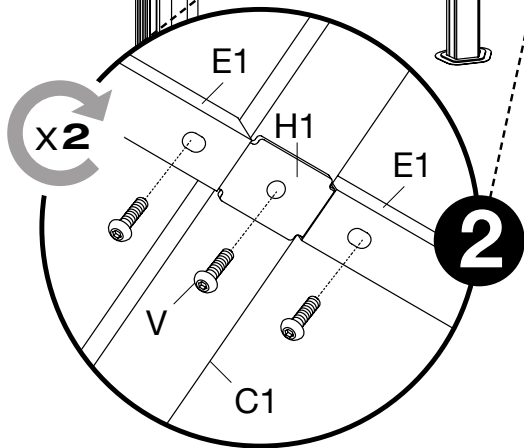
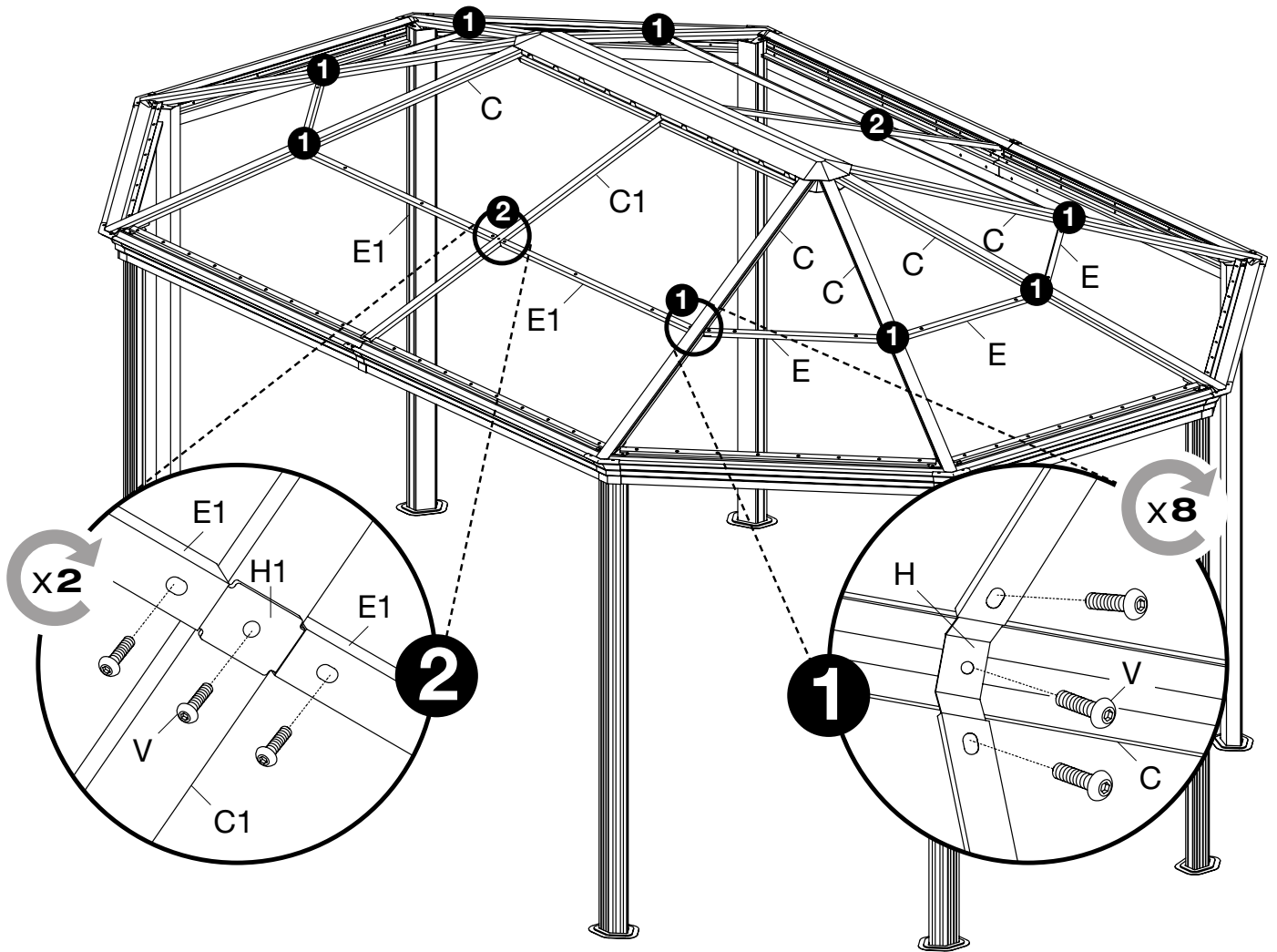

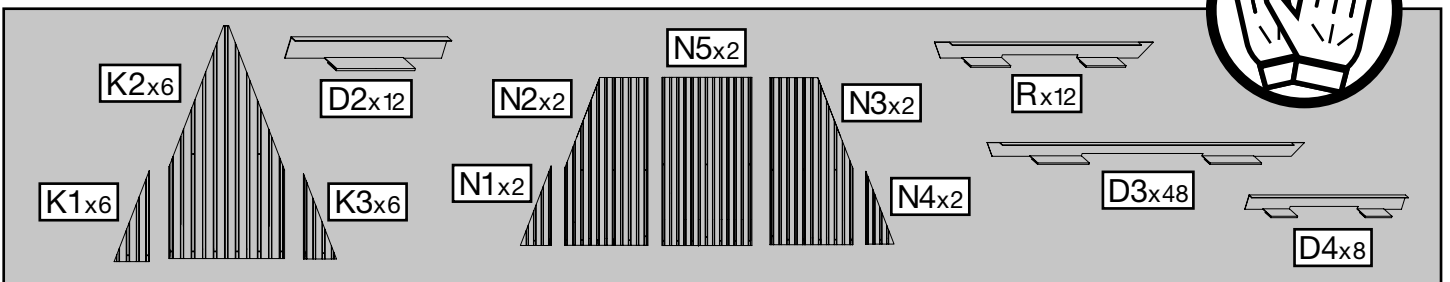
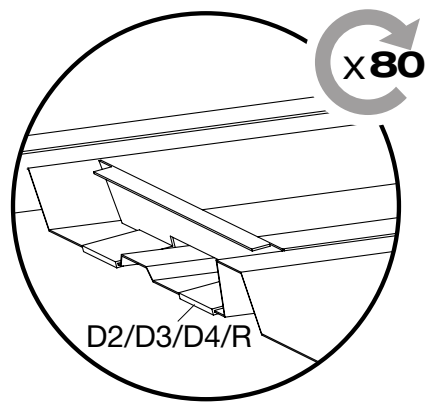
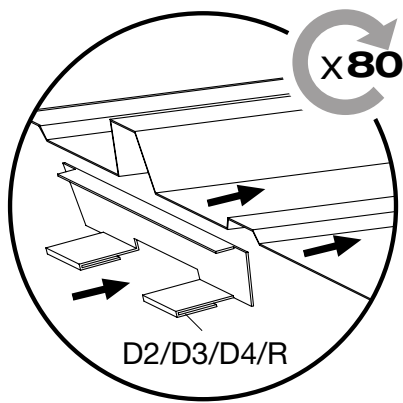
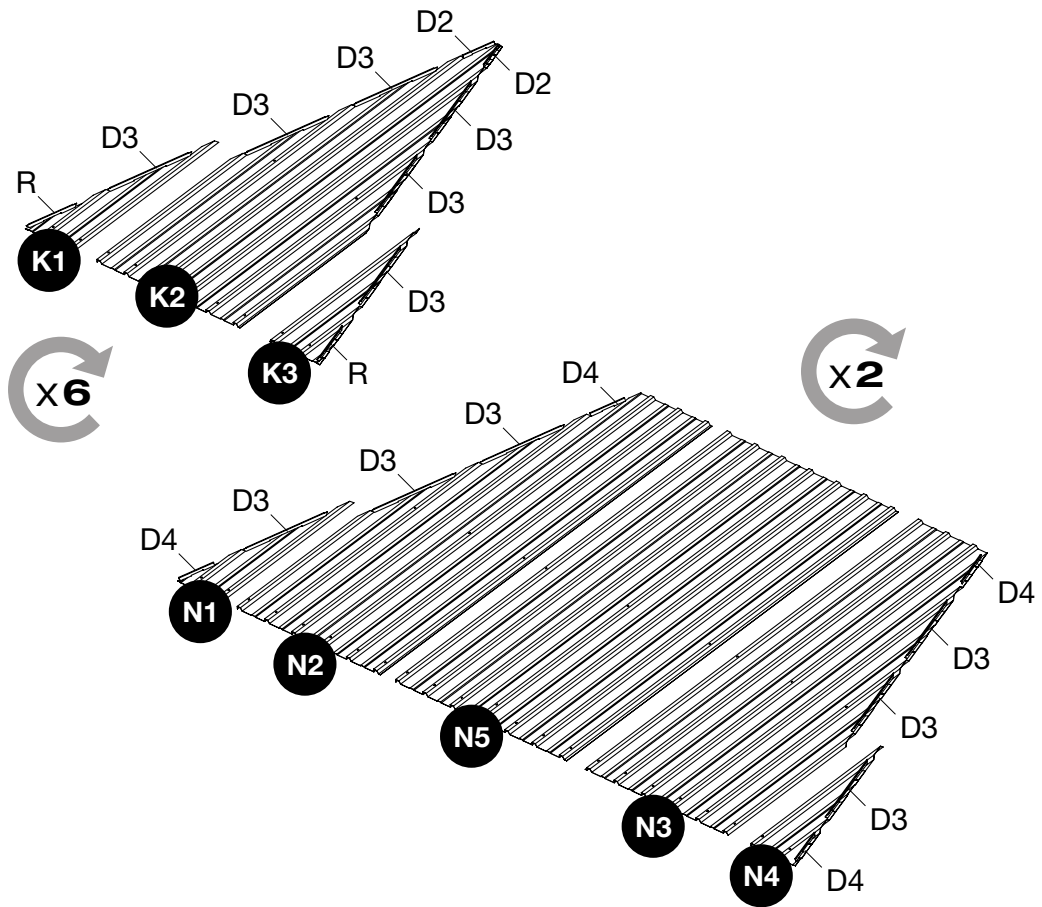

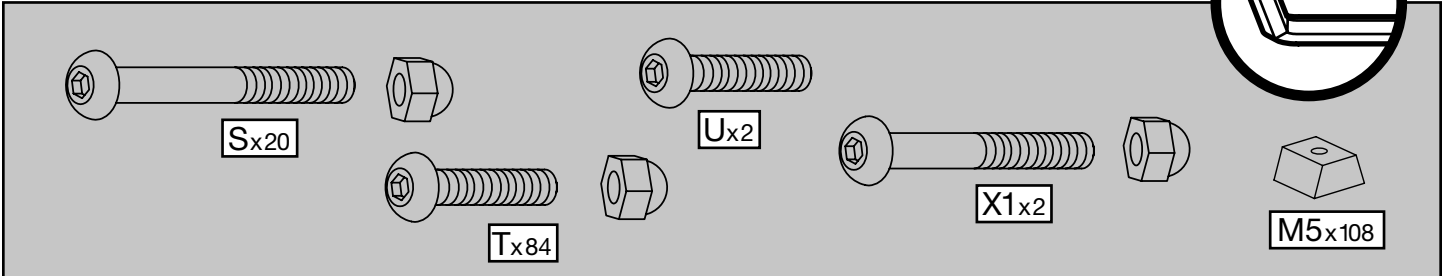
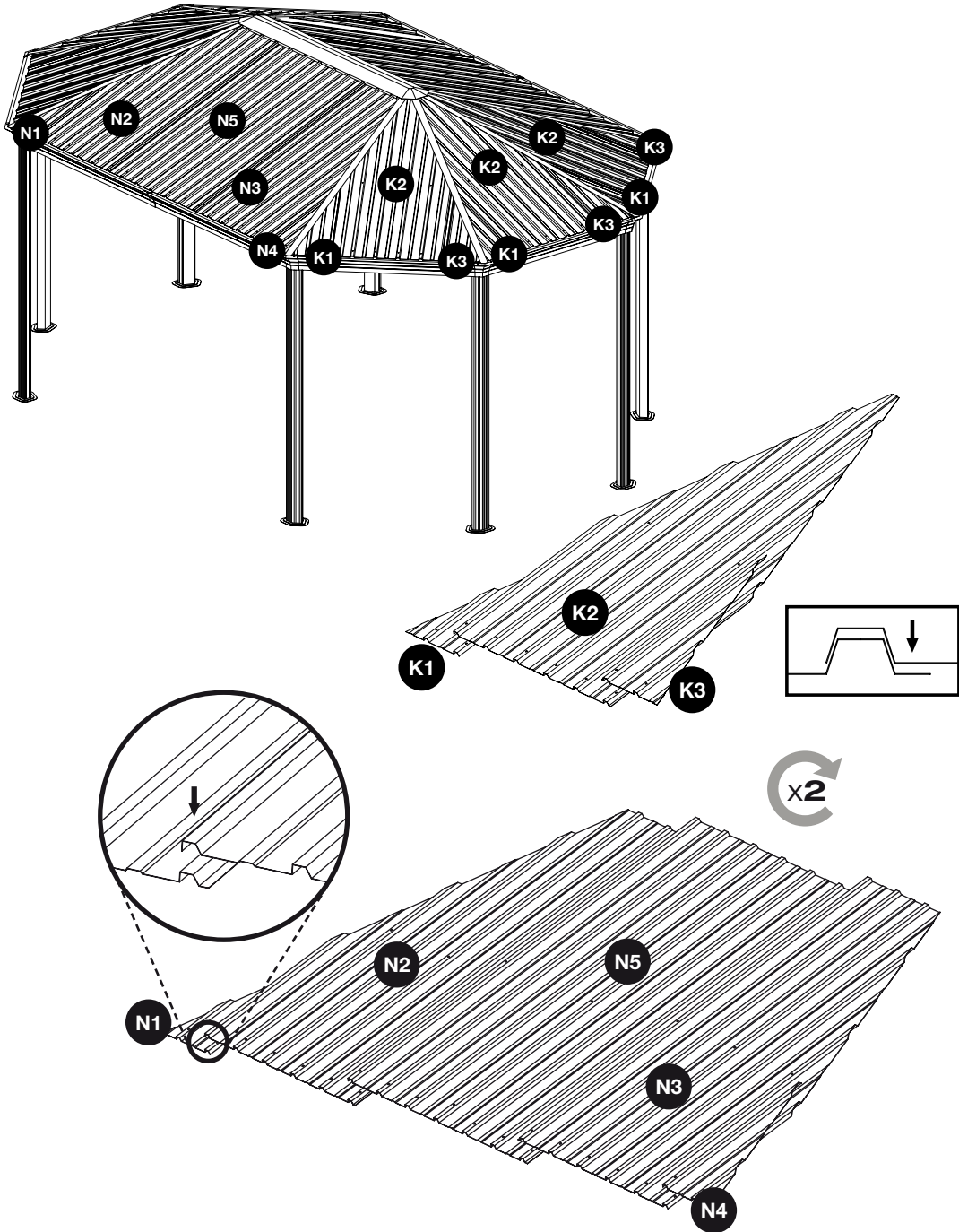

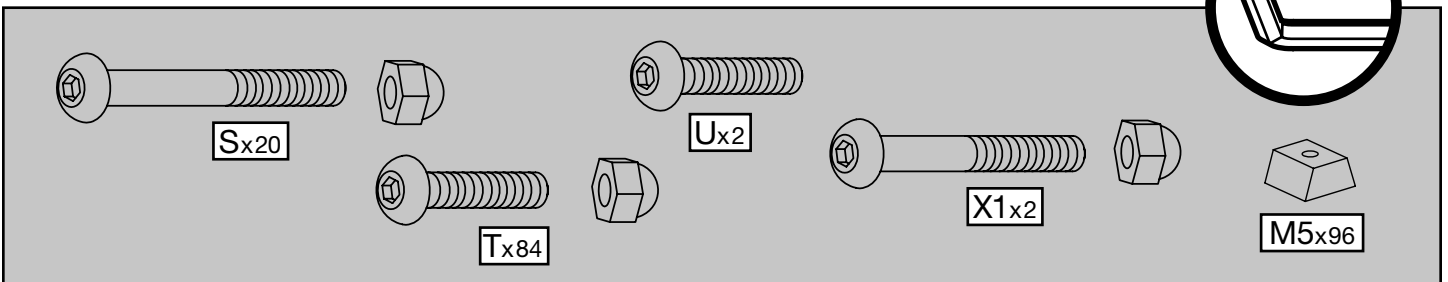
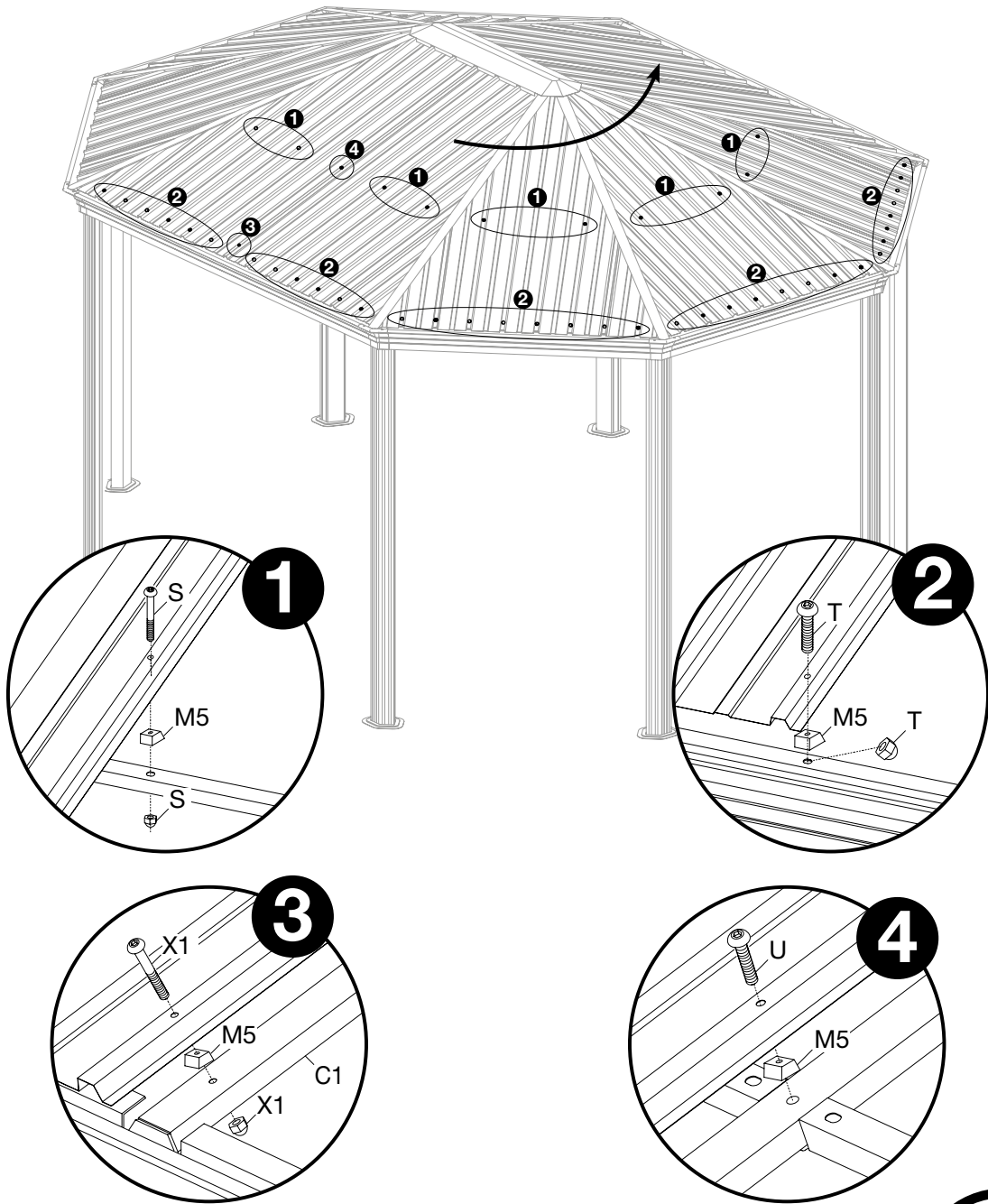

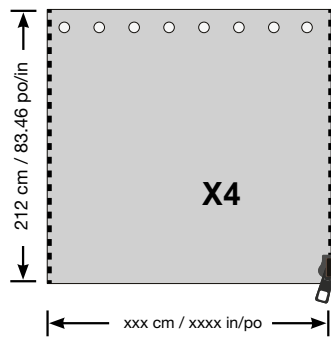
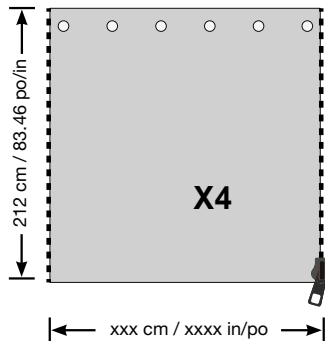
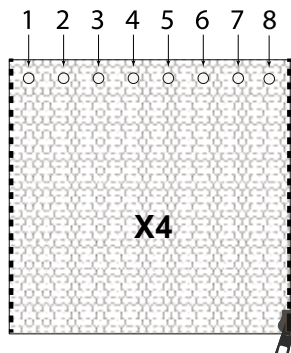
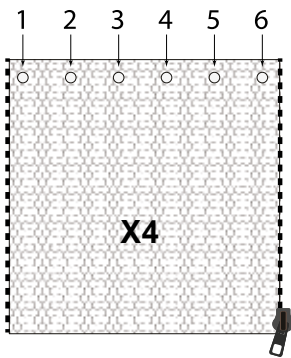
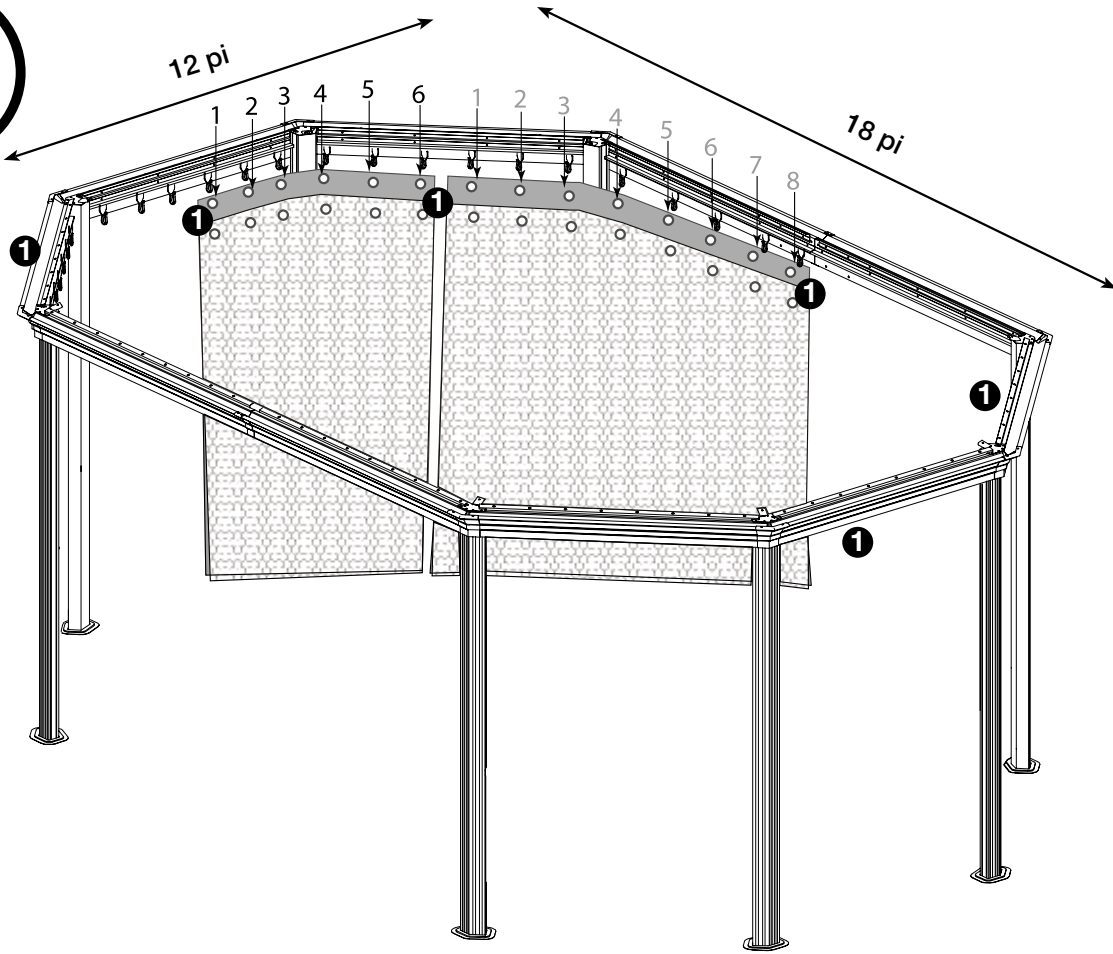
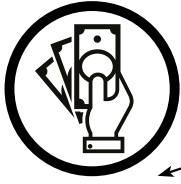



Clemens **HobbyTec**

**NOCH FRAGEN RUND
UM DAS PRODUKT
ODER ZUM AUFBAU?**

RUFEN SIE UNS AN:
+49 (0) 6571 929 222

SERVICE@CLEMENS-HOBBYTEC.DE

CLEMENS HOBBYTEC GMBH
RUDOLF-DIESEL-STRASSE 8
D-54516 WITTLICH

WWW.CLEMENS-HOBBYTEC.DE