

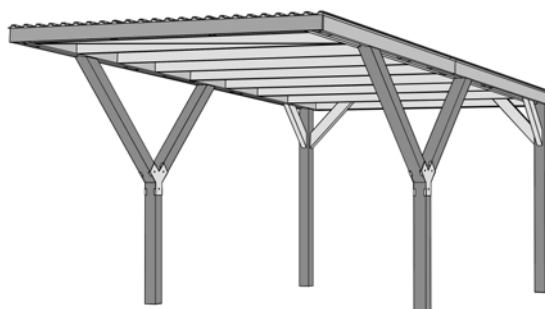

Montage-, Bedienungs- und Wartungsanleitung

en	ASSEMBLY, USER AND MAINTENANCE INSTRUCTIONS
fr	NOTICE DE MONTAGE, D'UTILISATION ET D'ENTRETIEN
it	ISTRUZIONI DI MONTAGGIO, USO E MANUTENZIONE

**Art.-Nr.
612.3260.30.00**



**Art.-Nr.
612.6060.30.00**

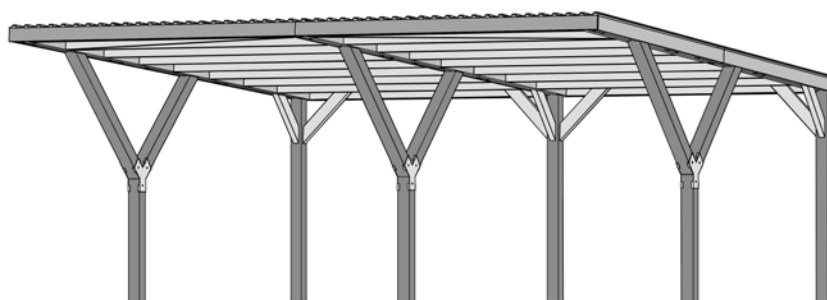

- de -

Sehr geehrte Kundin, sehr geehrter Kunde,
danke, daß Sie sich für ein weka – Produkt entschieden haben.

- Lesen Sie diese Anleitung vor dem Aufbau bitte vollständig durch, um Montagefehler oder Beschädigungen zu vermeiden.
- **WICHTIG !**
Prüfen Sie bitte sofort anhand der Packliste, ob das weka-Produkt vollständig und unbeschädigt bei Ihnen angekommen ist.
- Bitte vernichten Sie die Packliste erst nach Ablauf der Garantiezeit. Diese Liste dient Ihnen zur Kontrolle auf Vollständigkeit der Einzelteile und ist mit dem Kaufbeleg aufzubewahren. Eventuelle Beanstandungen können mit Hilfe dieser Liste problemlos behoben werden. Die Pos.-Nummern der Packliste stimmen nicht mit den Pos.-Nummern folgender Montageanleitung überein.
- Wir empfehlen Ihnen die Montage mit 3 Personen durchzuführen.
- Zur Verhütung von Unfällen ist zu vermeiden, daß sich Kinder während der Montage in unmittelbarer Nähe befinden.
- Weiterentwicklungen im Sinne des technischen Fortschritts behalten wir uns vor. So können geringfügige Abweichungen in den Darstellungen entstehen.
- Verpackungsmaterial nicht einfach wegwerfen! Papier-, Pappe- und Wellpappeverpackungen, sowie Kunststoffverpackungsteile sollten in die entsprechenden Sammelbehälter gegeben werden.

EMPFEHLUNGEN

- **Bitte bohren Sie alle Schraubverbindungen vor, um Beschädigungen an den Holzteilen zu vermeiden! Folgendes Zeichen macht Sie während der Anleitung nochmals darauf aufmerksam:**



- Schützen Sie das Holz vor stundenlanger, direkter Sonneneinwirkung oder Feuchtigkeit.
- Holz ist ein Naturprodukt. Verschiedenartige Färbungen, Äste und Rißbildung sind normal und haben keinen Einfluß auf die Statik.
- **ACHTUNG!**
- Die Maße sind im Verlauf der gesamten Montage regelmäßig zu kontrollieren!
- Voraussetzung für eine statikgerechte Montage ist die Verankerung der Pfosten mittels H-Pfostenträgern in Betonfundamenten. Die Pfostenträger sind als weka-Zubehör gegen Aufpreis erhältlich.
- **Den Fundamentplan erhalten Sie bei Ihrem Fachhändler!**
- Um das exakte Ausrichten der H-Anker zu erleichtern, kennzeichnen Sie die erforderlichen Pfostenabstände auf einem Richtholz und befestigen dort die Anker mit Schraubzwingen
- Danach hängen Sie die H-Anker in die zuvor ausgehobenen Fundamentlöcher, wobei ein Mindestabstand von 2 cm zwischen Fundamentoberkante und oberer Strebe einzuhalten ist.
- Nachdem Sie die Löcher mit Beton C25/30 aufgefüllt haben, müssen die Fundamente mindestens 3 Tage lang aushärten.

GARANTIEBESTIMMUNGEN

Die Firma weka Holzbau GmbH gewährt Ihnen 5 Jahre Garantie auf Konstruktion und Verarbeitungsqualität. Innerhalb der Garantiezeit werden fehlerhafte Teile kostenlos ersetzt. Die durch den Austausch entstehenden Kosten sind im Garantieanspruch nicht enthalten.

Garantieansprüche können nur in Verbindung mit Original-Packlisten und Kaufbeleg in Anspruch genommen werden.

Schadhafte oder defekte Einzelteile müssen vor dem Einbau beanstandet werden, da sonst der Garantieanspruch erlischt.

Von der Garantie sind Mängel ausgeschlossen, die bedingt sind durch:

- unsachgemäße Fundamente und Gründungen
- nicht gemäß dieser Anleitung durchgeführten Montage
- Schneelasten über 1,25 kN/m²
- eigene Veränderungen am Produkt
- fehlerhafte Pflege zur Erhaltung der vorhandenen Holzqualität
- das Vorherrschen von Windgeschwindigkeiten über Windstärke 7 (steifer Wind)
Im Binnenland sind hierbei Auswirkungen wie z.B. die Bewegung ganzer Bäume und die fühlbare Hemmung beim Gehen im Freien zu beobachten. Bei Verursachung von Mängeln aufgrund dieser Bedingungen wird keine Gewährleistung übernommen.
- Naturkatastrophen oder anderweitige gewaltsame Einwirkungen.

Bei Farbveränderungen, Rißbildung, Verzug oder ähnlichen Veränderungen, die bei Hölzern im Freien normal sind, besteht kein Reklamationsgrund. Auch die Dachplatten unterliegen Farbveränderungen.

Weitergehende Ansprüche und Folgeschäden fallen nicht unter die Garantiebestimmungen. Es gelten unsere allgemeinen Geschäftsbedingungen.

HINWEISE - DACHPLATTEN

- Die Dachplatten sind vor der Montage überdacht zu lagern oder gegen direkte Sonnenbestrahlung zu schützen! Hierzu eignet sich besonders weiße Folie. Bei mehreren übereinander gestapelten Platten kann sich ein Wärmestau bilden, der durch einen Brennglaseffekt zu Verformungen und Verfärbungen der Platten führt.
- Die Montage der Platten darf nicht bei einer Temperatur von unter +5°C bzw. über 30°C erfolgen.
- Um die Dichtheit Ihres Carports zu garantieren, ist beim Verlegen der Dachplatten mit Silikon (nicht im Lieferumfang enthalten) zu arbeiten.
- **Die Bohrung der Dachplatten ist in einer Größe von d = 8 mm vorzubohren, sonst erlischt der Garantieanspruch!**
- Beachten Sie, dass die Schrauben nicht zu fest angezogen werden, um das Arbeiten der Platten zu gewährleisten.

WERKZEUG

Folgendes Werkzeug sollten Sie vor Beginn der Montage zurecht gelegt haben.

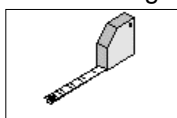

Bandmaß

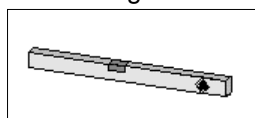

Wasserwaage

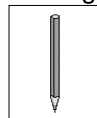

Bleistift

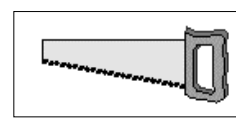

Säge

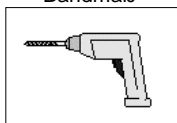

Bohrmaschine



Elektroschrauber

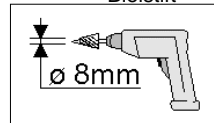

Kegelbohrer

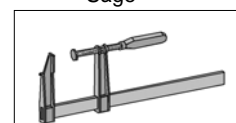

Schraubzwinge

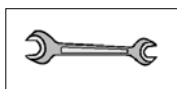

Schraubenschlüssel

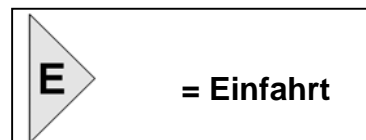

HINWEIS

In regelmäßigen Abständen sollten die Verschraubungen überprüft und nachgezogen werden. Dieses Produkt ist überwiegend aus Massivholz gefertigt und da es sich bei dem Werkstoff Holz um ein Naturprodukt handelt, kann es vorkommen das durch extreme Witterungseinflüsse, insbesondere nach langen Wärmeperioden, sich Trockenrisse bilden. Diese Trockenrisse sind keinesfalls ein Qualitätsmangel, sondern eine natürliche Erscheinung und je nach Wetterlage können sich diese Risse bis auf ein Minimum wieder verschließen. Darüber hinaus haben diese Trockenrisse, welche in Längsrichtung des Holzes auftreten, keinen Einfluss auf die Festigkeit und Belastbarkeit des Materials. Das heißt, die statischen Eigenschaften werden nicht beeinträchtigt.

- en -

Dear customer

Thank you very much for choosing a weka product.

- Read these instructions through completely before assembling your product in order to avoid errors in assembly or damage.
- **IMPORTANT**
Please use the enclosed packing list to check immediately that your weka product has been delivered complete and intact.
- Please do not dispose of the packing list before the guarantee period has expired. This list enables you to check that all the individual parts are present. It should be retained along with the proof of purchase. Any complaints which may arise can probably be easily rectified with this list. The item numbers on the packing list do not correspond to the item numbers in the following assembly instructions.
- We recommend that 3 people carry out the assembly.
- In order to prevent accidents, we recommend that children are kept out of the direct vicinity during assembly.
- We reserve the right to make further technological developments. This means that there may be minor deviations in the illustrations.
- Please do not simply throw away the packaging material. Paper, card and corrugated board as well as plastic packaging materials should be placed in the correct collection containers.

RECOMMENDATIONS

- **Please drill pilot holes for all screw connections to avoid damaging the wood. The following symbol in the instructions will indicate when this is necessary:**



- Protect the wood from hours of direct sunlight and moisture.
- Wood is a natural product. Fluctuations in colour, knots and cracks are normal and have no influence on the statics.
- A prerequisite for successful assembly, is the anchoring of the studs in the concrete foundation using H stud supports. The stud supports are available as weka accessories for an additional cost.

NOTE!

- The dimensions are to be checked regularly during the course of the entire installation!
- **A foundation plan can be obtained from your specialist dealer!**
- In order to facilitate the precise alignment of the H anchors, mark the necessary post clearances on a piece of guide wood and fix the anchors in place with screw clamps
- Then suspend the H anchors in the base holes already prepared. A minimum clearance of 2 cm is to be maintained between the upper edge of the foundation and the upper strut.
- After the holes have been filled with C25/30 concrete, the foundation must be allowed to set for at least 3 days.

GUARANTEE CONDITIONS

weka Holzbau GmbH provides you with a 5-year guarantee for design and processing quality. Within the guarantee time, faulty parts will be replaced free of charge. Costs arising as a result of the exchange are not included in the guarantee claim.

Guarantee claims may only be made in conjunction with the original packing list and proof of purchase.

Damaged or defective parts must be rejected prior to installation otherwise any warranty claim shall be terminated.

Excluded from the guarantee are defects caused by:

- improper subsoil and foundations

- assembly not carried out in accordance with these instructions
- snow load in excess of 1.25 kN/m²
- your own alterations to the product
- defective care in the maintenance of the current wood quality
- prevailing winds in excess of force 7 (stiff wind)

Inland, consequences such as the movement of whole trees and any noticeable impedance when walking in the open air are to be observed. No defects due to these conditions will give rise to a guarantee.

- Natural catastrophes or other violent occurrences.

Fluctuations in colour, crack formation, warping or similar changes which are completely normal outdoors are no grounds for making a claim.

Further claims and consequential damage do not fall under the guarantee regulations. Our General Terms and Conditions apply.

NOTES – ROOF TILES

- Prior to mounting, the roof tiles are to be stored undercover and out of direct sunlight. This applies in particular to white foils. Heat may build up under a stack of tiles leading to distortion and discoloration of the tiles due to the burning glass effect.
- Roof tiles must not be mounted in temperatures below +5°C or above 30°C.
- In order to guarantee the impermeability of your car port, silicon is to be used when laying the roof tiles (not included in the delivery).
- **The roof tiles are to be pre-drilled with holes with a diameter = 8 mm.**
- Please note that the screws are not to be screwed down too tightly in order to guarantee the function of the tiles.
- Note: No false floor may be installed or thermal insulation provided below the roof tiles. There must be adequate ventilation beneath the roof tiles.

TOOL

You should have the following tools to hand before beginning assembly. (Not supplied.)

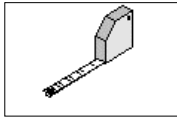

Spring tape measure

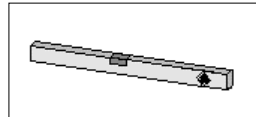

Spirit level

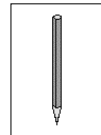

Pencil

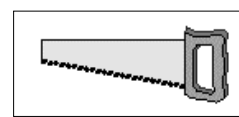

Mitre saw/hand disk saw

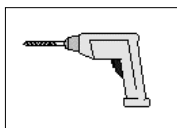

Drill



Electric screwdriver

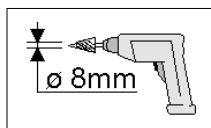

Taper drill

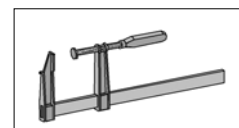

Screw clamp

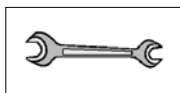

Spanner

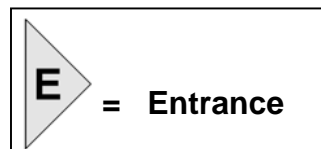

Il est conseillé de vérifier et de resserrer les assemblages vissés à intervalles réguliers. Ce produit est essentiellement fabriqué en bois massif. Le bois étant un matériau naturel, il se peut que des conditions climatiques extrêmes, notamment après de longues périodes de chaleur, entraînent la formation de fentes de sécheresse. Ces fentes de sécheresse ne constituent en aucun cas un défaut de qualité, mais un phénomène naturel. Selon la situation météorologique, ces fentes peuvent se refermer quasi-intégralement. De plus, ces fentes de sécheresse, qui apparaissent dans le bois dans le sens de la longueur, n'exercent aucune influence sur la solidité et la résistance du matériau. Autrement dit, les propriétés statiques ne sont pas affectées.

- fr -

Chère Cliente, cher Client

Nous vous remercions d'avoir choisi un produit weka.

- Lisez entièrement la présente notice avant de procéder à l'assemblage afin d'éviter les erreurs et les dommages.
- **IMPORTANT !**
Veillez vérifier immédiatement, à l'aide de la liste des pièces, si le produit weka est arrivé complet et en bon état.
- Ne détruisez la liste des pièces qu'une fois la garantie écoulee. Cette liste vous permet de vérifier si les pièces détachées sont complètes et doit être conservée avec le justificatif d'achat. Elle vous permettra de faire valoir aisément d'éventuelles réclamations. Les numéros de pos. de la liste des pièces ne sont pas identiques aux numéros de pos. de la présente notice de montage.
- Nous vous recommandons d'effectuer le montage à 3 personnes.
- Afin de prévenir tout accident, éviter la présence d'enfants à proximité durant le montage.
- Nous nous réservons le droit d'apporter aux produits des modifications dans le cadre de l'évolution technique. De légères différences sont par conséquent possibles par rapport aux illustrations.
- Ne pas jeter simplement le matériel d'emballage! Les emballages en papier, carton et carton ondulé doivent être déposés dans le container de tri correspondant.

RECOMMANDATIONS

- **Pré-percez tous les assemblages vissés afin d'éviter d'endommager les éléments en bois! Ceci vous est rappelé par le symbole suivant dans la notice:**



- Evitez d'exposer le bois au soleil ou à l'humidité pendant des heures.
- Le bois est un produit naturel. Les différentes colorations, les nœuds et les fissures sont normaux et n'ont aucun effet sur la tenue statique.

ATTENTION !

- **Les cotes doivent être vérifiées régulièrement tout au long du montage !**
- Le montage en respect des règles de la statique exige d'ancrer les poteaux à l'aide de supports en H dans des fondations en béton. Les supports de poteaux sont disponibles à titre d'accessoires weka contre supplément.
- **Le plan de fondation vous sera remis par votre revendeur!**
- Pour faciliter l'alignement précis des éléments d'ancrage en H, repérez les distances nécessaires entre les poteaux sur une latte repère et fixez-y les éléments d'ancrage à l'aide de serre-joints
- Suspendez ensuite les éléments d'ancrage en H dans les trous préalablement aménagés de la fondation en laissant au moins 2 cm entre le bord supérieur de la fondation et l'entretoise supérieure.
- Après avoir rempli les trous de béton C25/30, laissez durcir les fondations pendant au moins 3 jours.

CLAUSES DE GARANTIE

weka Holzbau GmbH accorde une garantie de 5 ans sur la construction et la qualité de fabrication. Au cours de la période de garantie, les pièces défectueuses sont remplacées gratuitement. Les coûts liés au remplacement ne sont pas couverts par la garantie.

L'original de la liste des pièces et l'original du justificatif d'achat sont nécessaires pour faire valoir tous droits relatifs à la garantie.

Des pièces défectueuses ou endommagées doivent faire l'objet d'une réclamation avant le montage, après celui-ci elles ne seront plus garanties.

La garantie ne couvre pas les vices dus à:

- des fondations et soubassements non conformes

- un montage non conforme aux présentes instructions
- des charges dues à la neige supérieures à 1,25 kN/m²
- des modifications du produit
- un manque d'entretien en vue du maintien de la qualité du bois
- la prédominance de vents d'une force supérieure à 7 (grand frais)
 - A l'intérieur des terres, tenir compte à ce sujet par ex. du fait que les arbres entiers bougent ou qu'il est difficile de se déplacer à l'extérieur. Aucun recours au titre de la garantie ne peut être accepté pour les vices consécutifs à ces situations.*
- des catastrophes naturelles ou à l'emploi de la force.

Les changements de couleur, la formation de fissures, la déformation ou les autres modifications de ce type sont normaux pour le bois à l'extérieur et ne constituent pas des motifs de réclamation.

Les autres droits et dommages secondaires n'entrent pas dans le cadre des clauses de garantie. En application de nos conditions générales de vente.

Remarques – Panneaux de toit

- Les panneaux de toit doivent être entreposés sous abri avant le montage ou protégés du soleil ! L'utilisation de film blanc est particulièrement adaptée. L'empilement de panneaux peut conduire à une accumulation de chaleur qui, par effet de loupe, entraîne une déformation et une décoloration des panneaux.
- Les panneaux ne doivent pas être montés par une température inférieure à +5°C ou supérieure à 30°C.
- Pour garantir l'étanchéité de votre abri-garage, utiliser de la silicone (non fournie) pour la pose des panneaux.
- **Pré-percer les panneaux de toit à d = 8 mm !**
- Les vis ne doivent pas être trop serrées pour permettre aux panneaux de travailler.
- Attention : Ne pas installer de faux plafond ou d'isolation thermique sous les panneaux de toit. Une aération suffisante est absolument indispensable sous les panneaux de toit !

OUTIL

Pour le montage, nous vous recommandons de préparer les outils suivants.
(N'est pas compris dans la fourniture!)

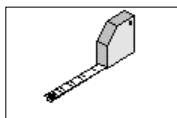

Décimètre à ruban

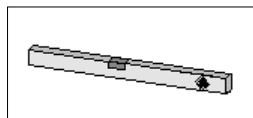

Niveau à bulle

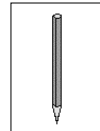

Crayon

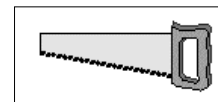

Scie à denture fine

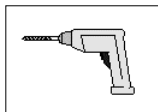

Perceuse

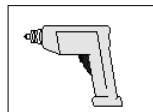

visseuse électrique

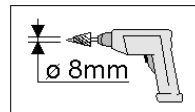

alésoir conique

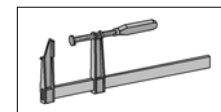

serre-joint

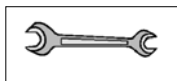

Clé



Il est conseillé de vérifier et de resserrer les assemblages vissés à intervalles réguliers. Ce produit est essentiellement fabriqué en bois massif. Le bois étant un matériau naturel, il se peut que des conditions climatiques extrêmes, notamment après de longues périodes de chaleur, entraînent la formation de fentes de sécheresse. Ces fentes de sécheresse ne constituent en aucun cas un défaut de qualité, mais un phénomène naturel. Selon la situation météorologique, ces fentes peuvent se refermer quasi-intégralement. De plus, ces fentes de sécheresse, qui apparaissent dans le bois dans le sens de la longueur, n'exercent aucune influence sur la solidité et la résistance du matériau. Autrement dit, les propriétés statiques ne sont pas affectées.

- it -

Egredi clienti,

ci congratuliamo con voi per avere scelto un prodotto weka.

- Prima del montaggio leggete con cura le presenti istruzioni al fine di evitare errori di montaggio o danni.
- **IMPORTANTE !**
Controllate subito con l'ausilio della lista di imballaggio che il prodotto weka sia stato fornito completo e senza danni.
- Vi preghiamo di conservare la lista di imballaggio solo alla scadenza del periodo di garanzia. Questa lista serve per controllare la completezza della fornitura e deve essere conservata insieme allo scontrino. Con l'ausilio della lista è possibile risolvere eventuali reclami. I numeri di posizione della lista di imballaggio non corrispondono con i numeri di posizione delle seguenti istruzioni di montaggio.
- Raccomandiamo di eseguire il montaggio in 3 persone.
- Per scongiurare eventuali incidenti tenere lontano i bambini dal luogo di montaggio
- Ci riserviamo di apportare modifiche ai fini del progresso tecnologico. Per tale motivo è possibile che nelle rappresentazioni vengano a crearsi lievi differenze.
- Non gettare via il materiale di imballaggio! La carta, il cartone normale e ondulato cosiccome gli imballaggi in plastica devono essere smaltiti negli appositi contenitori di raccolta.

RACCOMANDAZIONI

- **Per evitare danni agli elementi in legno si raccomanda di preforare tutti i punti di avvitaggio a vite! Il presente simbolo richiama la vostra attenzione su tale particolare nel corso delle istruzioni:**



- Proteggete il legno dall'irradiazione solare diretta e dall'umidità prolungate.
- Il legno è un prodotto naturale. Differenti irregolarità cromatiche, la ramificazione e la crepatura sono da considerarsi normali e non hanno alcuna influenza sulla statica.

ATTENZIONE!

- Durante il montaggio le misure devono essere controllate regolarmente!
- Per un corretto montaggio statico è necessario ancorare i montanti nelle fondamenta in calcestruzzo con supporti ad H. I supporti dei montanti sono disponibili come accessorio weka su sovrapprezzo.
- **Per uno schema delle fondamenta rivolgetevi al vostro rivenditore specializzato!**
- Per facilitare l'allineamento dell'elemento di ancoraggio ad H contrassegnate le necessarie distanze fra i montanti con un regolo e fissate in tali punti gli elementi di ancoraggio per mezzo di morsetti .
- Successivamente inserite gli elementi di ancoraggio ad H nei pozzetti di fondamenta creati in precedenza, rispettando una distanza di 2 cm fra il bordo superiore delle fondamenta e la traversa superiore.
- Dopo aver riempito i pozzetti con calcestruzzo C25/30, le fondamenta devono asciugare per almeno 3 giorni.

Condizioni di garanzia

La weka Holzbau GmbH vi offre una garanzia di 5 anni sugli elementi costruttivi e sulla qualità di lavorazione. Durante il periodo di garanzia i componenti difettosi vengono sostituiti gratuitamente. La garanzia non comprende i costi causati dalla sostituzione di componenti difettosi.

La garanzia può essere applicata solamente se accompagnata dalla lista di imballaggio e dallo scontrino di acquisto originali.

Prima di procedere con il montaggio, le parti danneggiate o difettose devono essere eliminate, in caso contrario la garanzia decade.

La garanzia non copre difetti causati da:

- fondamenta e fondi non appropriati
- un montaggio non eseguito come specificato nelle presenti istruzioni

- carichi di neve maggiori di 1,25 kN/m²
- modifiche al prodotto apportate di propria iniziativa
- manutenzione errata del legno
- presenza costante di venti maggiori di forza 7
nell'entroterra sono visibili effetti quali l'oscillazione di interi alberi e palesi difficoltà nel cammino all'aperto. il produttore non risponde nel caso di danni derivanti da tali cause.
- catastrofi naturali o altri fattori di intervento violento.

Per modifiche cromatiche, formazione di crepe, distorsioni o simili cambiamenti, normali per legni all'aperto, non vi è motivo di reclamo. La garanzia non copre ulteriori rivendicazioni e danni derivati. Valgono le nostre condizioni generali di vendita.

Istruzioni – Piastre del tetto

- Prima dell'assemblaggio, le piastre vanno conservate in un luogo riparato o lontano dalla luce solare diretta! A tale scopo, si presta particolarmente bene un telone bianco. In caso di sovrapposizione di più piastre, può verificarsi un ritardo nella trasmissione del calore, che può a sua volta causare un effetto di focalizzazione, con conseguenti deformazioni o alterazioni del colore!
- L'assemblaggio delle piastre non va eseguito in presenza di temperature inferiori ai +5°C o superiori ai 30°C.
- Per garantire la tenuta stagna del vostro Carport, va impiegato del silicone (non incluso nella partita) per l'installazione delle piastre.
- **I fori per l'installazione delle piastre del tetto devono avere un diametro di = 8 mm!**
- Vi preghiamo di considerare che le viti non vanno strette troppo, per consentire il funzionamento delle piastre.
- Attenzione: Sotto le piastre del tetto non è consentito inserire tramezzi o materiali isolanti. È assolutamente necessario garantire un'adeguata ventilazione al di sotto delle piastre del tetto!

UTENSILE

Prima di iniziare con il montaggio tenere a portata di mano i seguenti utensili.
(Non compreso nella fornitura!)

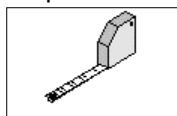

metro a nastro

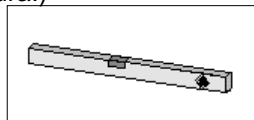

livella ad acqua

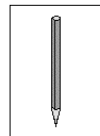

Matita

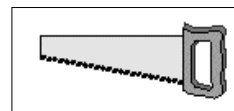

sega fine

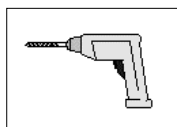

trapano

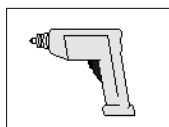

avvitatore elettrico

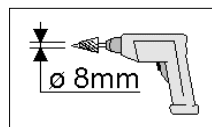

trapano conico

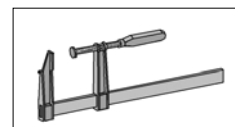

morsetto

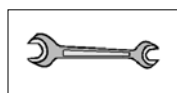







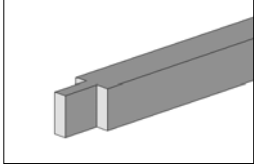
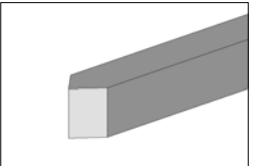
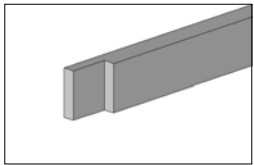
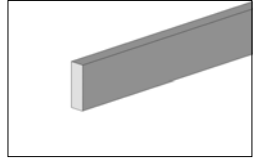
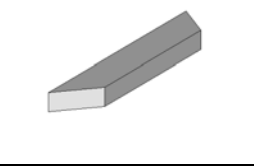
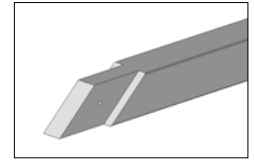
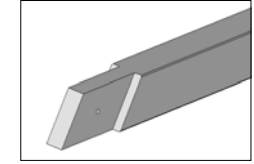

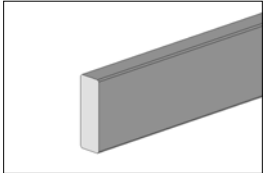
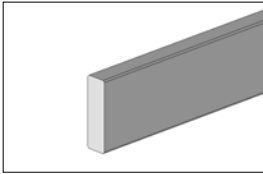
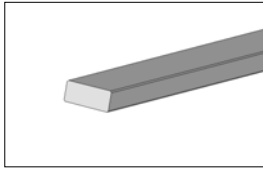
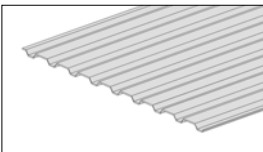
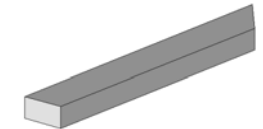
chiave



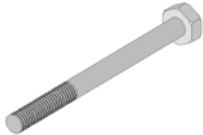



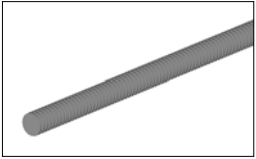
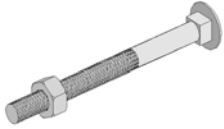



Si raccomanda di controllare periodicamente tutti i collegamenti a vite e di riserrarli all'occorrenza. Questo prodotto è prevalentemente realizzato con legno massiccio e poiché nel materiale legno si tratta di un prodotto naturale, in seguito a condizioni atmosferiche estreme, in particolare durante i lunghi periodi estivi, non è da escludere una formazione di fessure di essiccamento. Queste fessure di essiccamento non sono in nessun caso un difetto di qualità, bensì un fenomeno naturale. A seconda delle condizioni atmosferiche queste fessure possono di nuovo chiudersi, lasciando soltanto uno spiraglio minimo. Inoltre, queste fessure di essiccamento, che si formano in senso longitudinale sul legno, non hanno alcun influsso sulla stabilità e sul carico del materiale. Ciò significa che non vengono in alcun modo pregiudicate le caratteristiche statiche.

Pos	Bild	Abmessung [mm]	Stück	
			612.3260	612.6060
①		120 / 120 / 2134	2	3
②		120 / 120 / 1237	2	3
③		60 / 120 / 3050	4	8
④		40 / 120 / 3000	4	4
⑤		60 / 120 / 800	4	7
⑥		120 / 120 / 1643	2	3
⑦		120 / 120 / 1895	2	3

Pos	Bild	Abmessung [mm]	Stück	
			612.3260	612.6060
8		40 / 120 / 2700	9	18
9		20 / 120 / 3040	2	4
10		40 / 120 / 2787	1	2
11		1074 x 3100	6	12
12		60 / 120 / 900	2	3
13		60 / 120 / 200	6	9
14		40 / 60 / 120	4	8

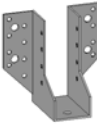
Pos	Bild	Abmessung [mm]	Stück	
			612.3260	612.6060
15		M12 x 150	6	9
16		13mm	12	18
17		13,5 / 44	16	32
18		M12	6	18
19		M12 x 220	-	8
20		M12 x 180	16	16
21		4,0 x 35	485	980

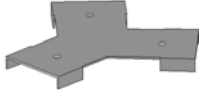
Pos	Bild	Abmessung [mm]	Stück	
			612.3260	612.6060
22		48 / 12	28	42
23		5,0 x 120	20	35
24		5,0 x 80	12	25
25		4,5 x 70	10	40
26		4,0 x 40	25	40
27		4,5 x 45	165	320
28		40 x 110	18	36

Pos	Bild	Abmessung [mm]	Stück	
			612.3260	612.6060
29			4	6
30		2,5 x 16	2	2
31			1	1

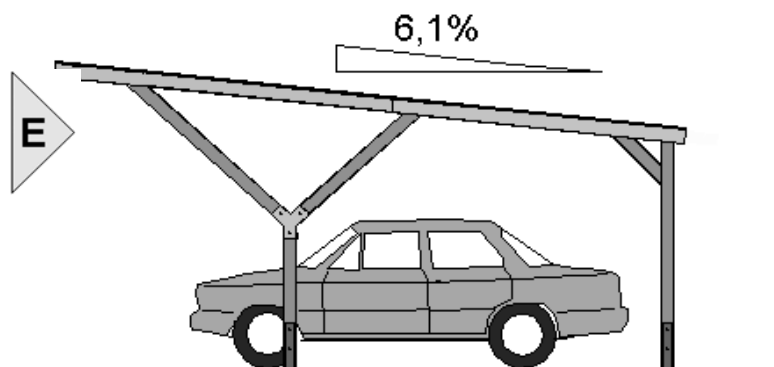
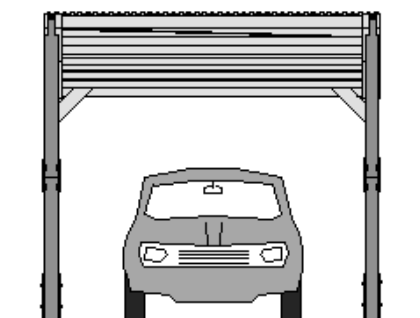

GRUNDRISSE:

Art.-Nr.: 612.3260.00.00

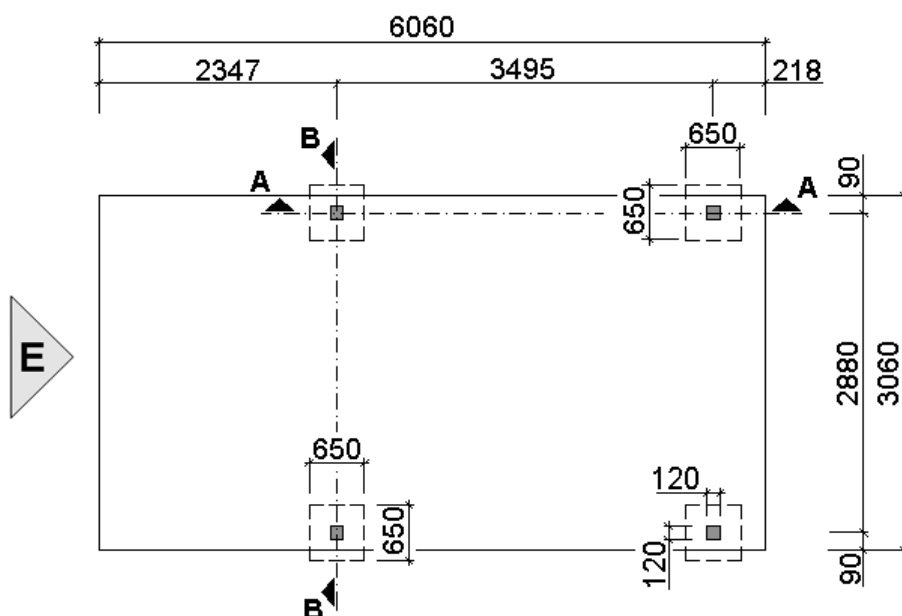

Art.-Nr.: 612.6060.00.00

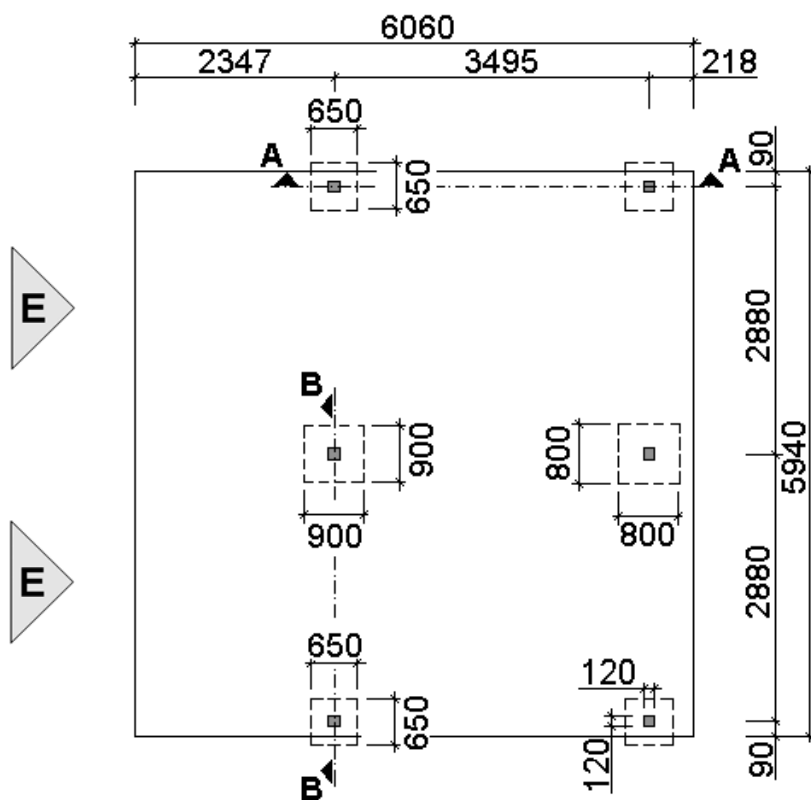

SCHNITTE:

A - A

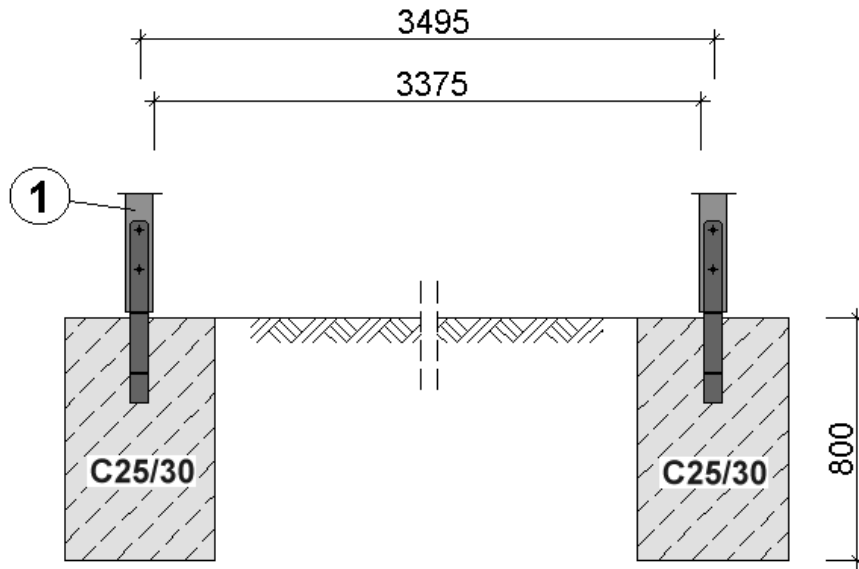

B - B

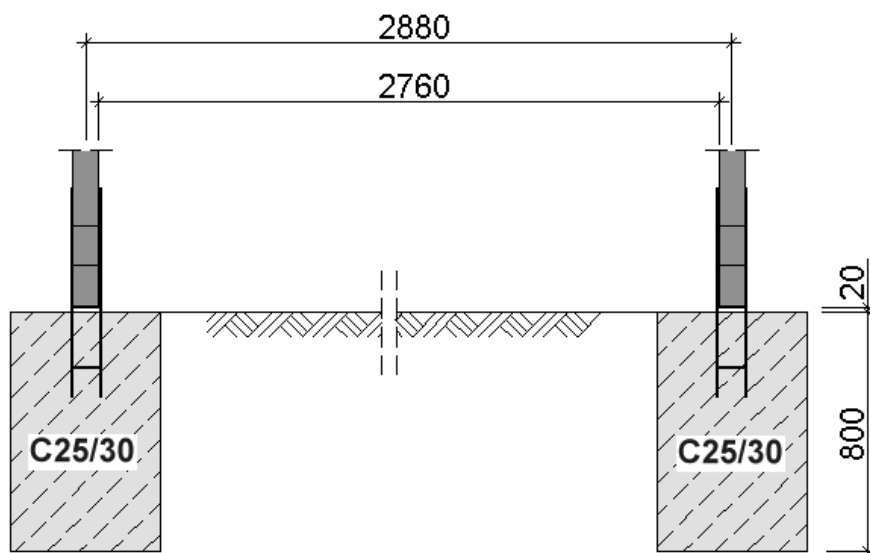

Art.-Nr.: 612.3260.00.00

de	Pfosten
en	Stud
fr	poteau
it	montante

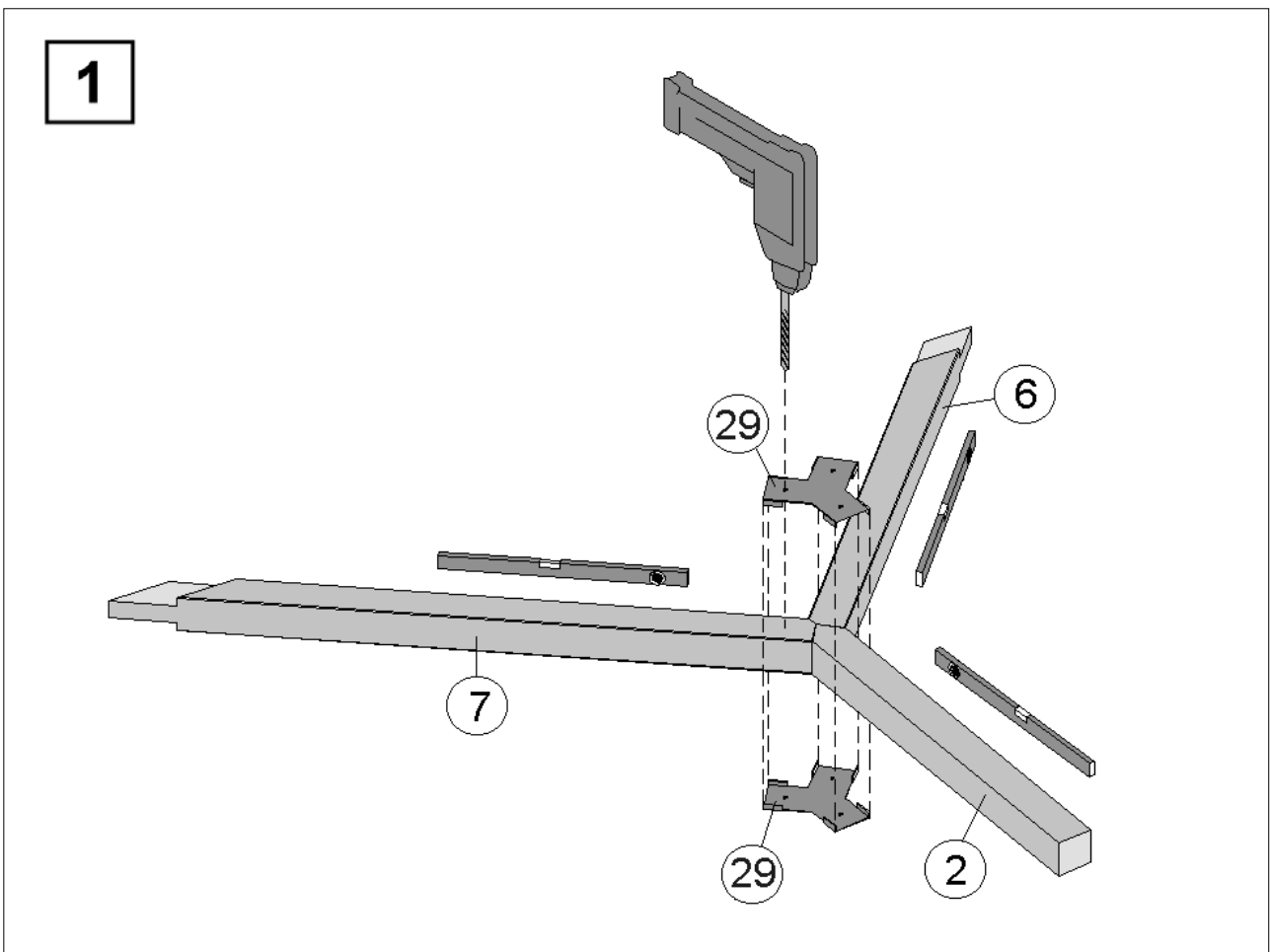
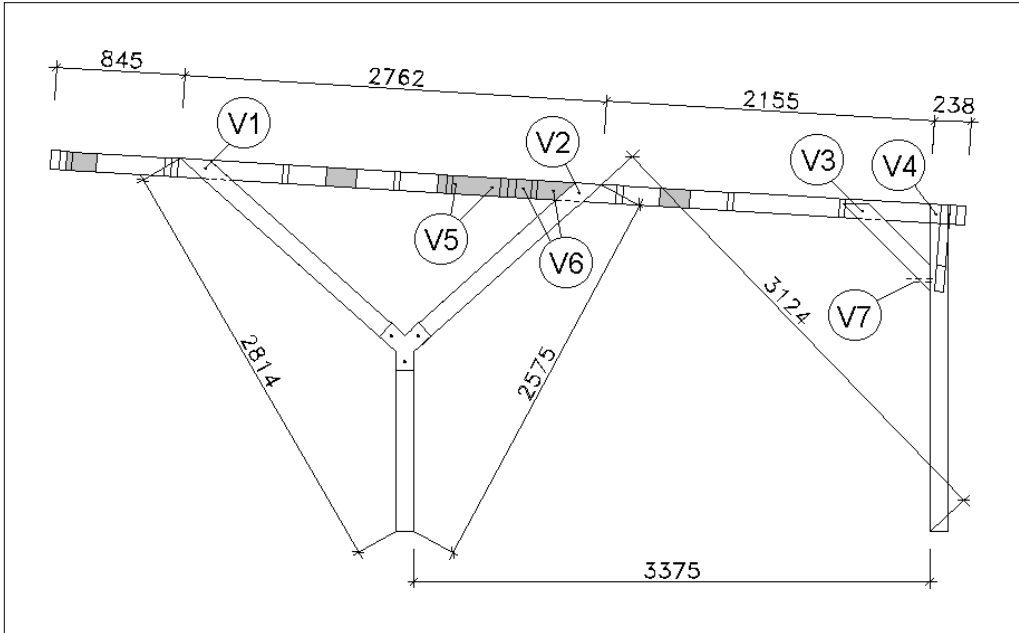
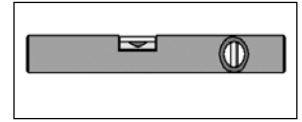
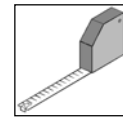
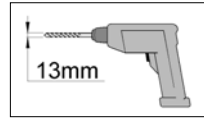
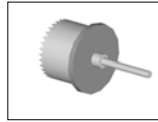

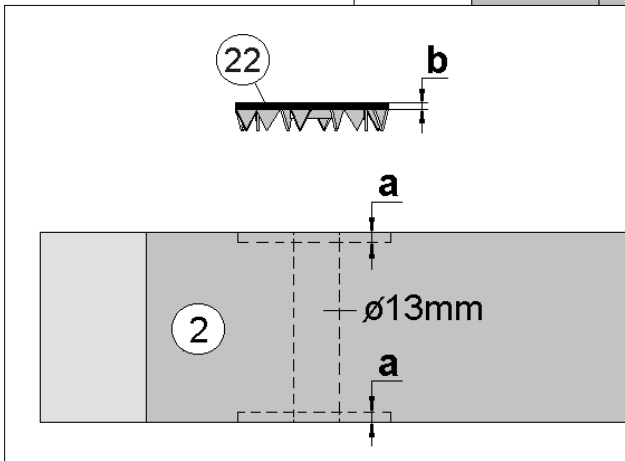
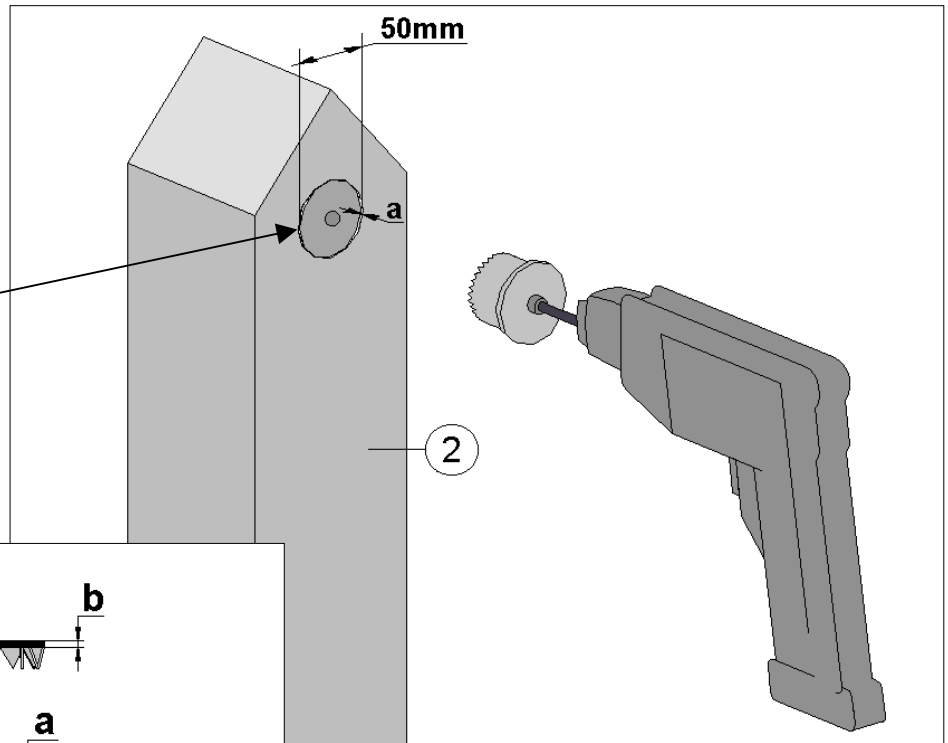
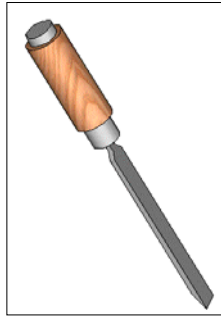
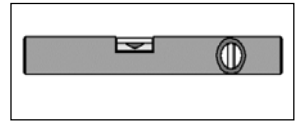
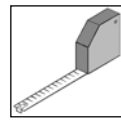
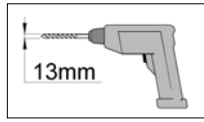
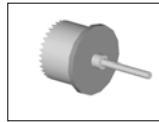

$$a=b$$

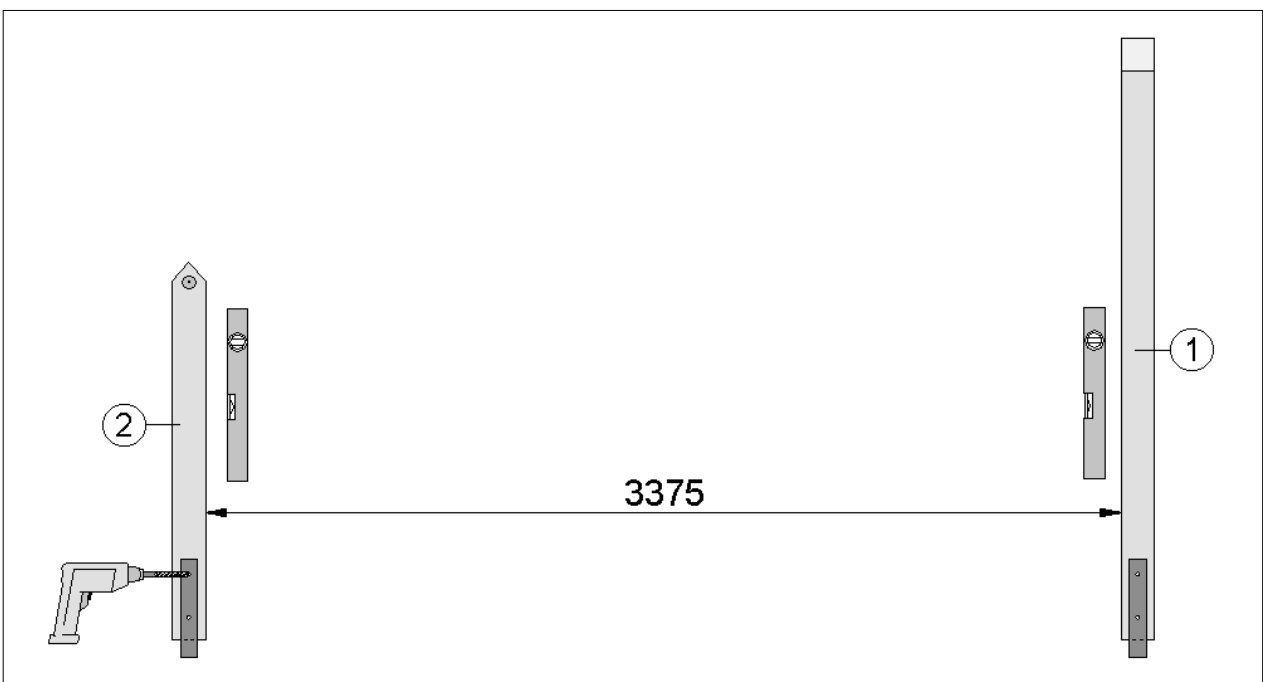

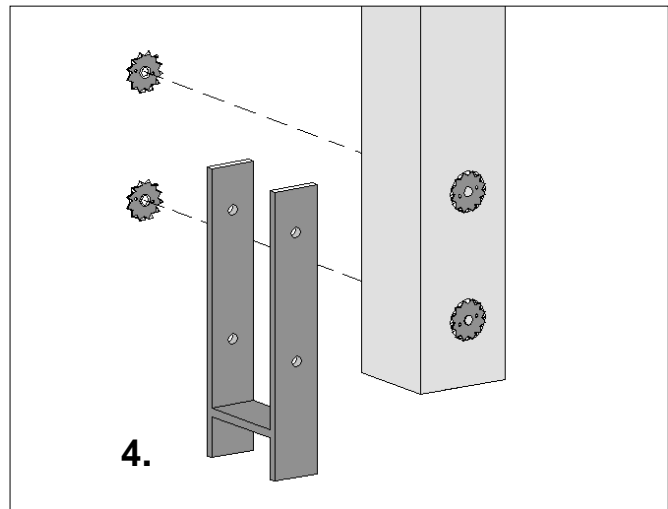
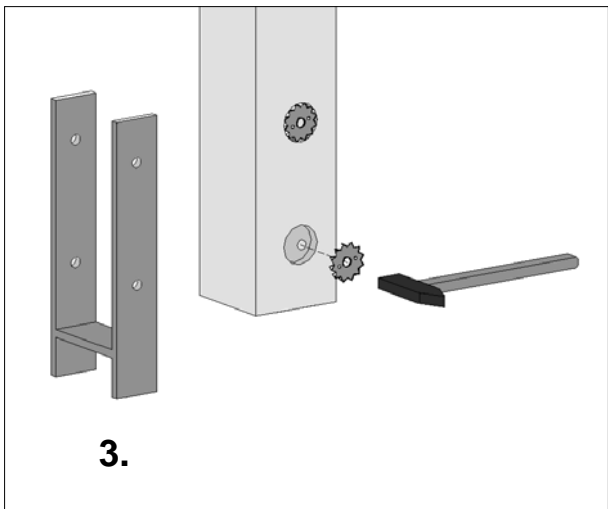
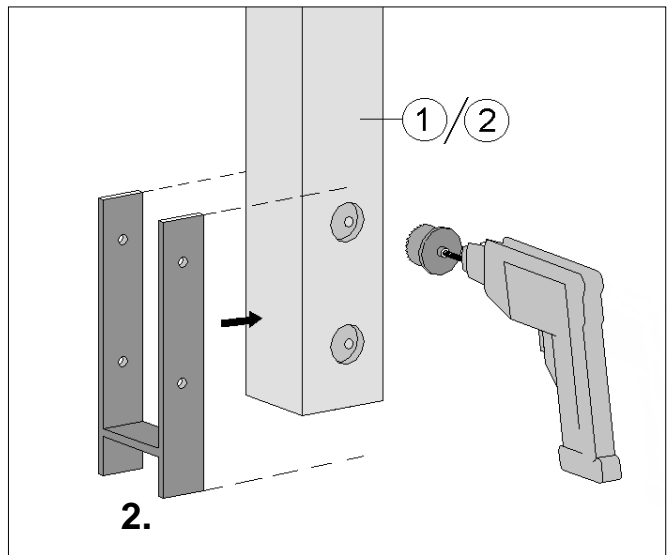
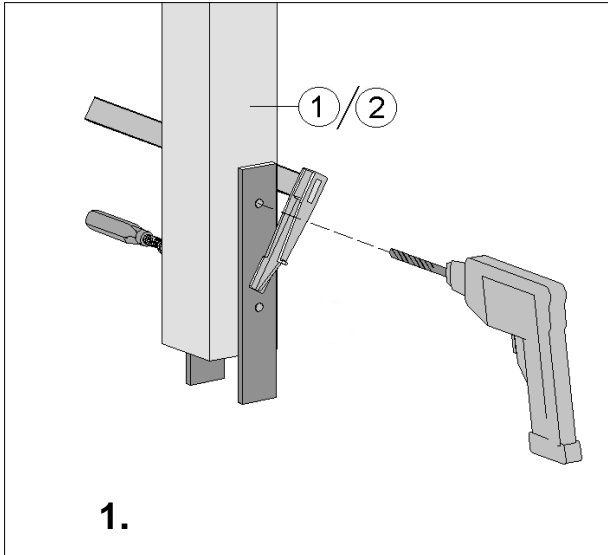
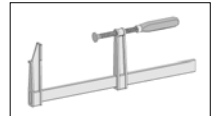
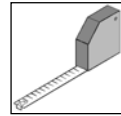
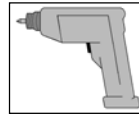
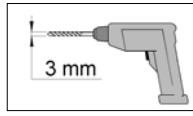
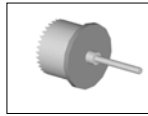

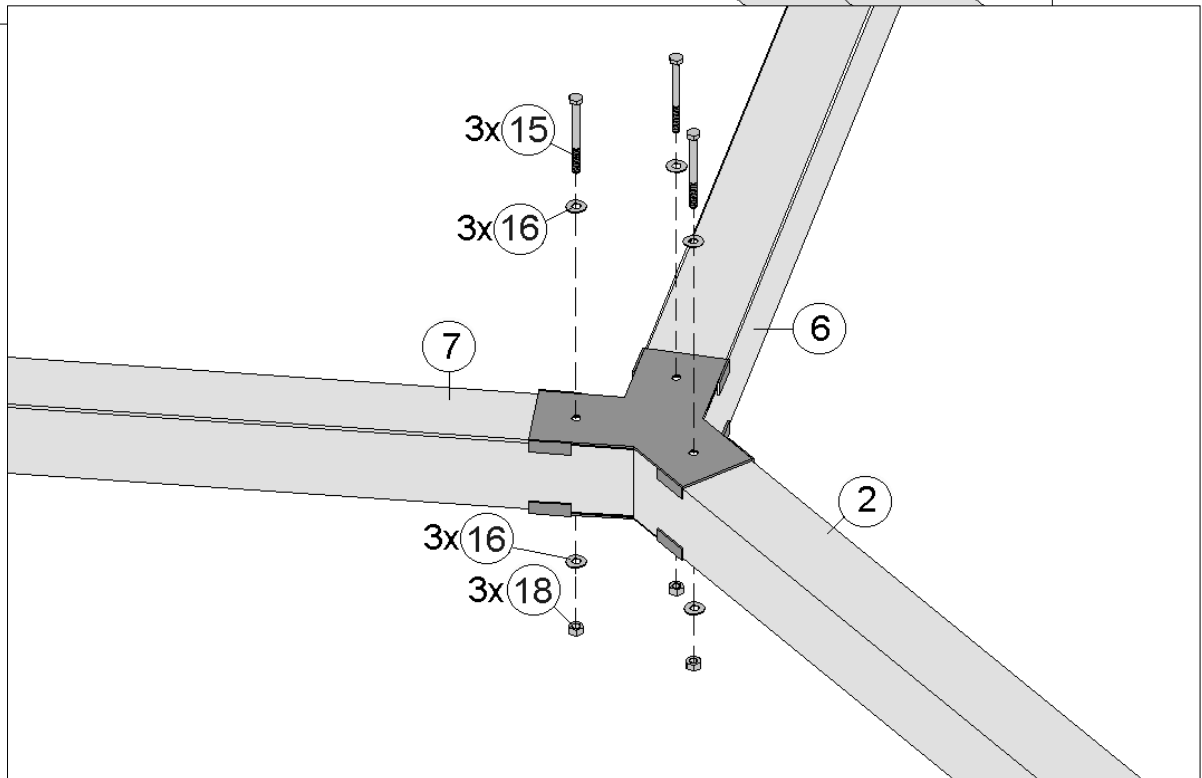
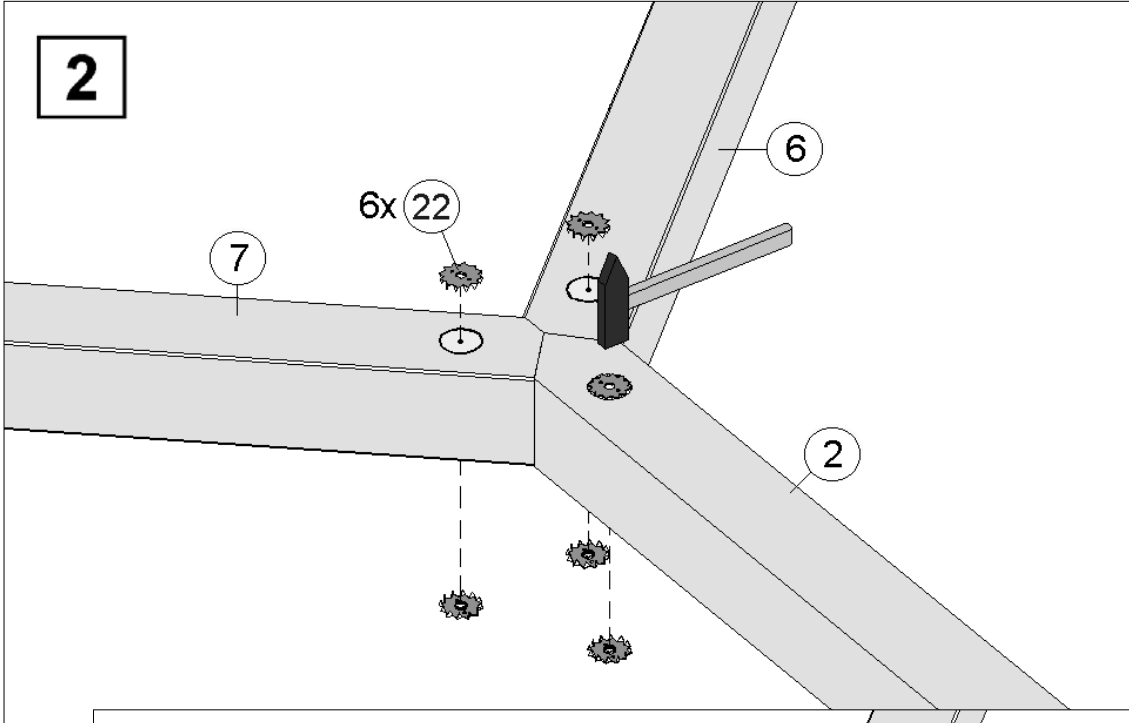
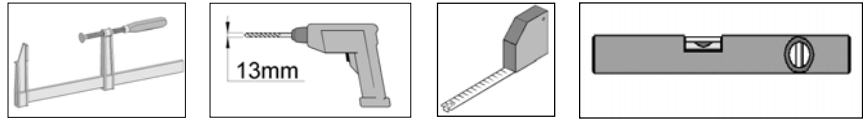

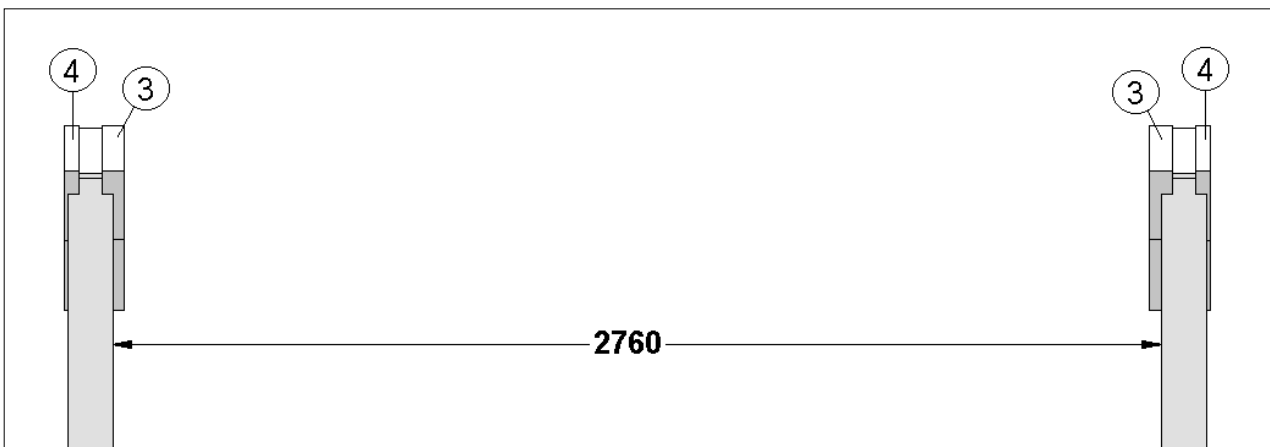
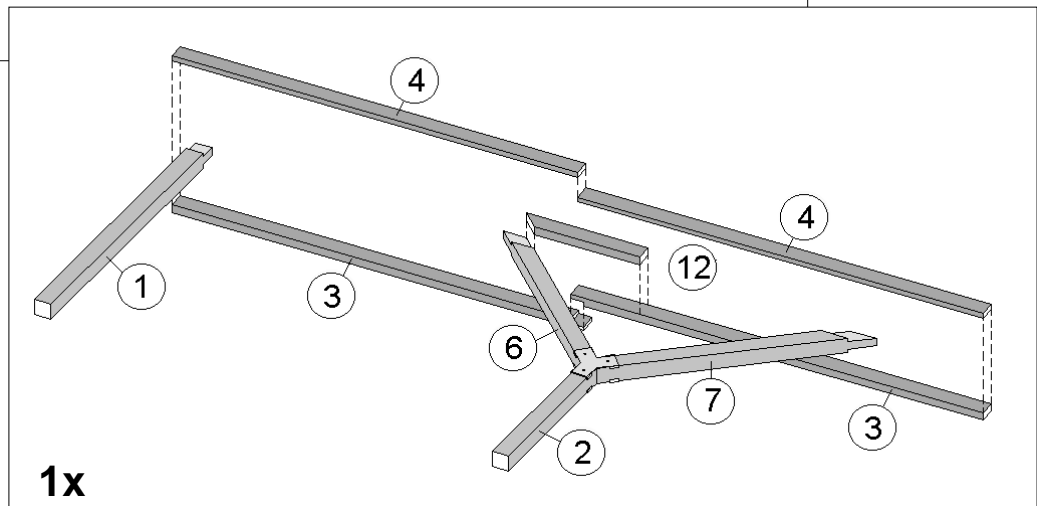
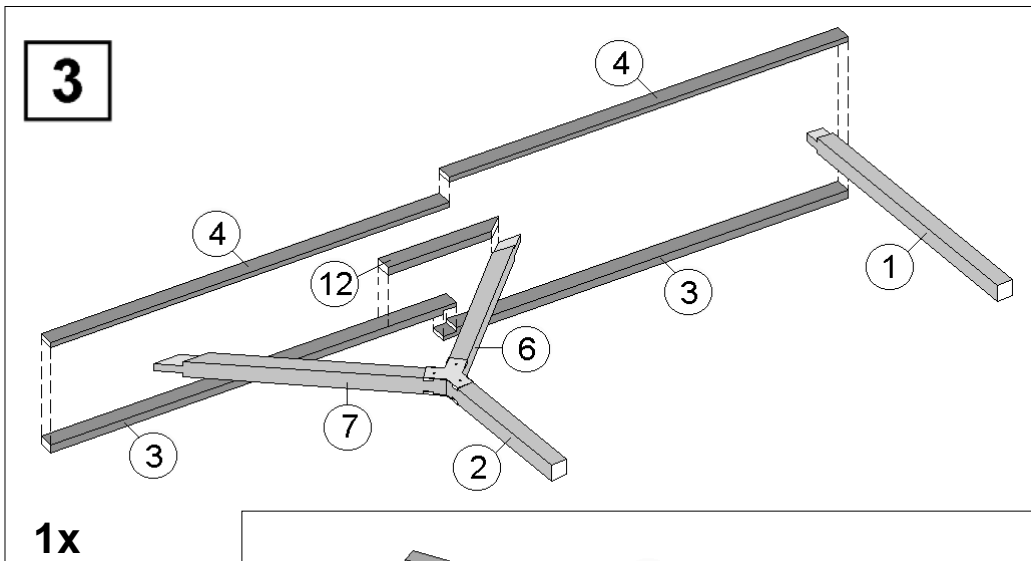
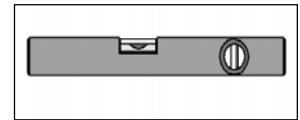
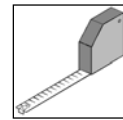
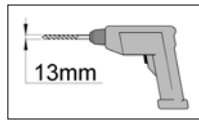

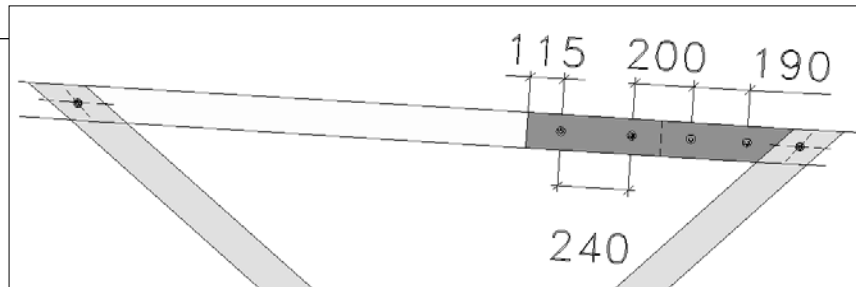
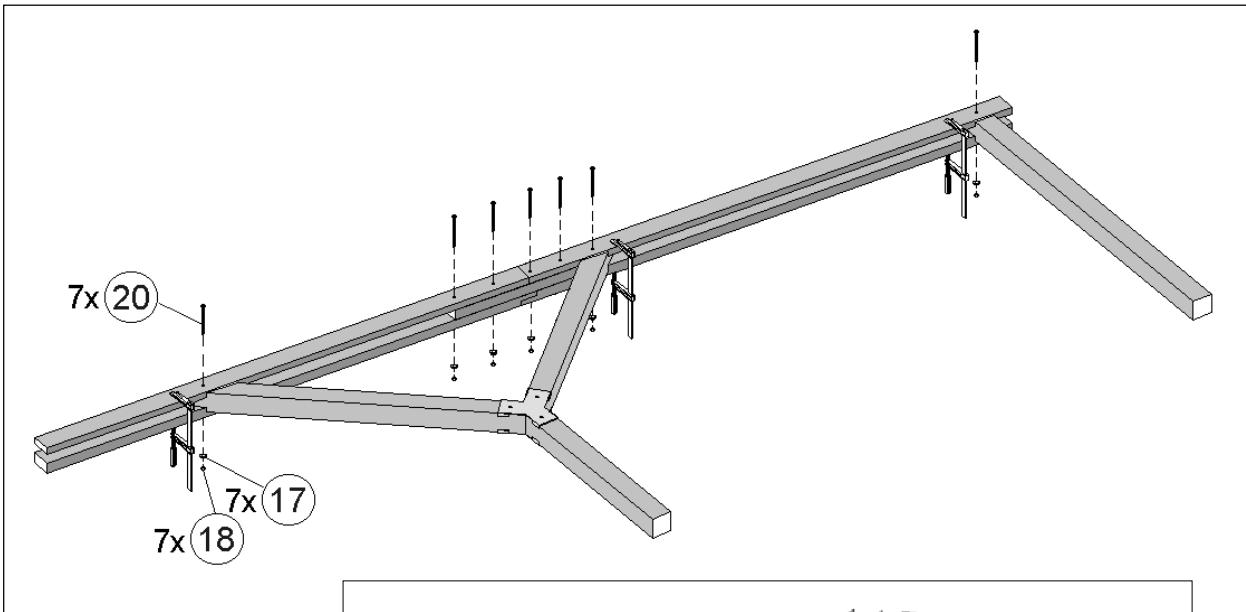
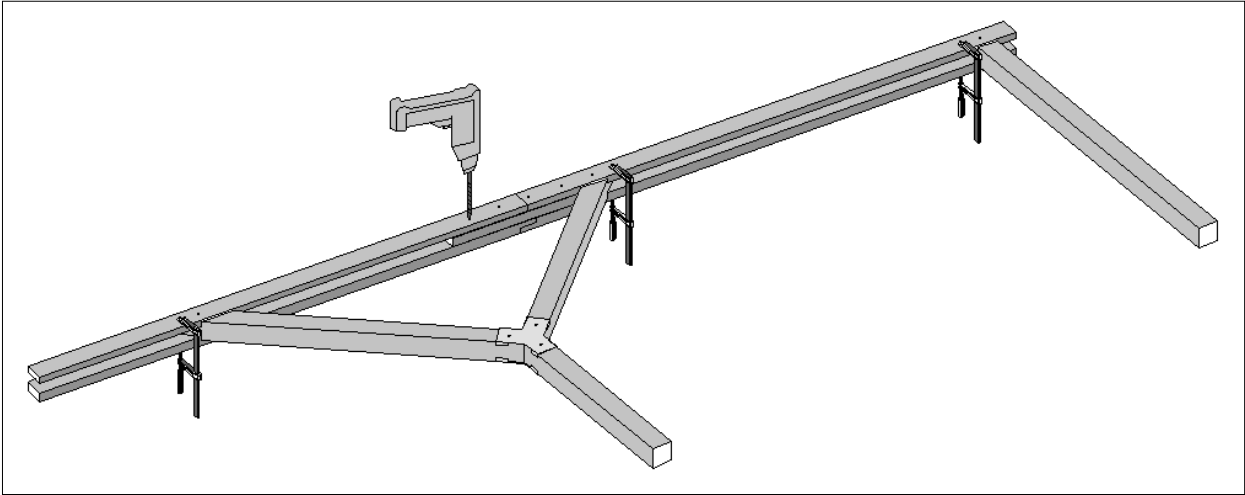
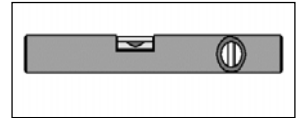
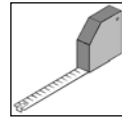
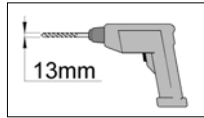
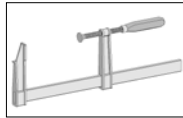

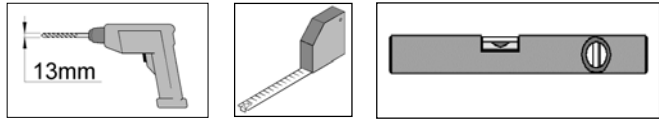

4

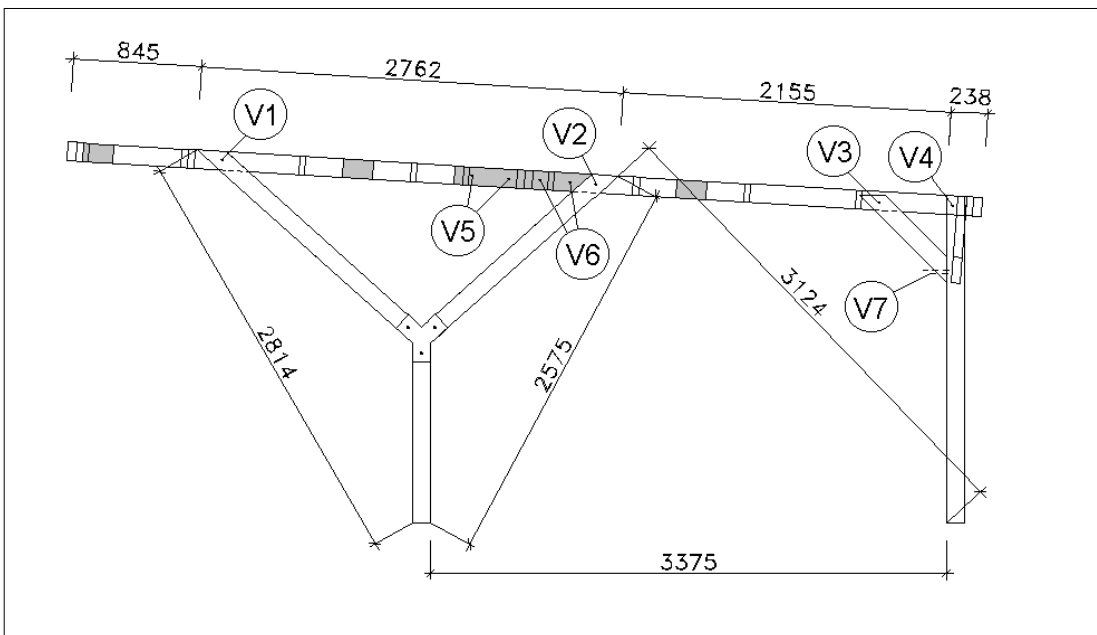
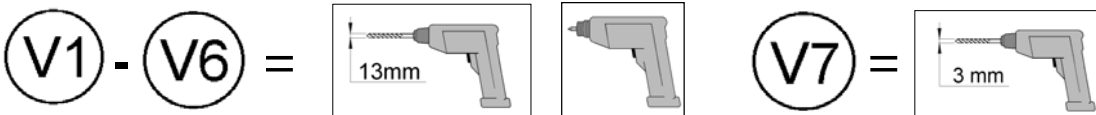
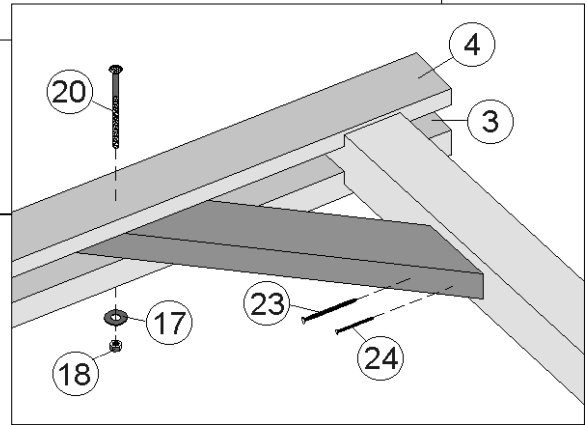
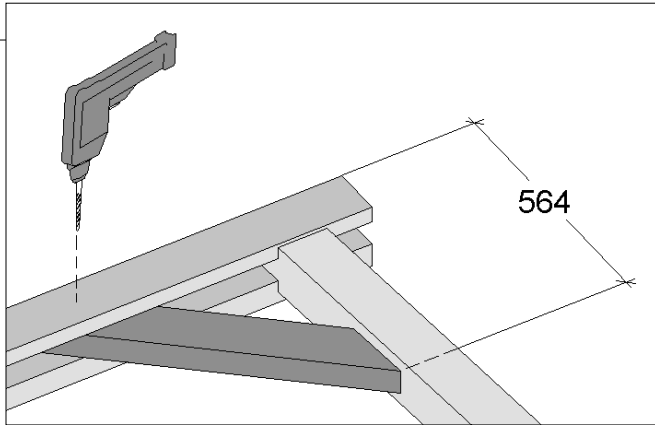
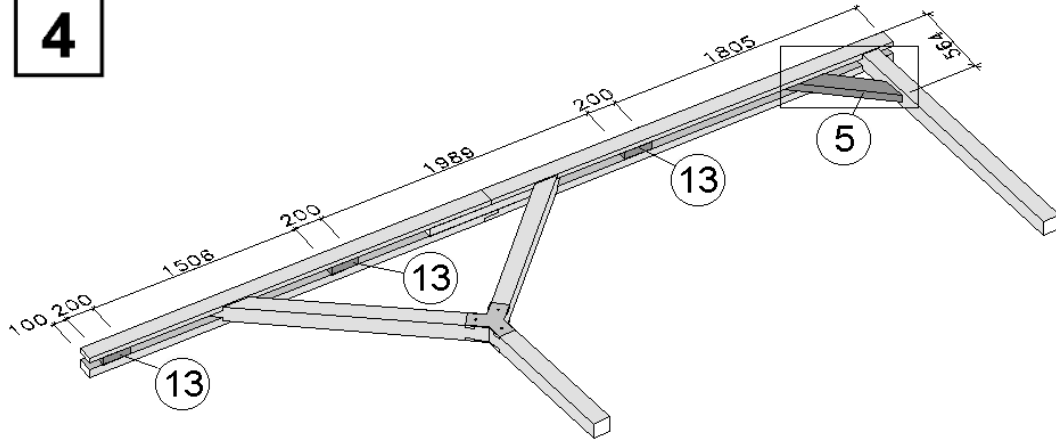

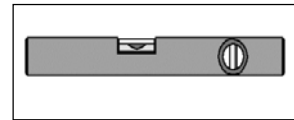
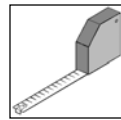
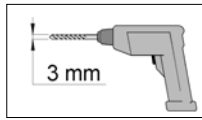

5

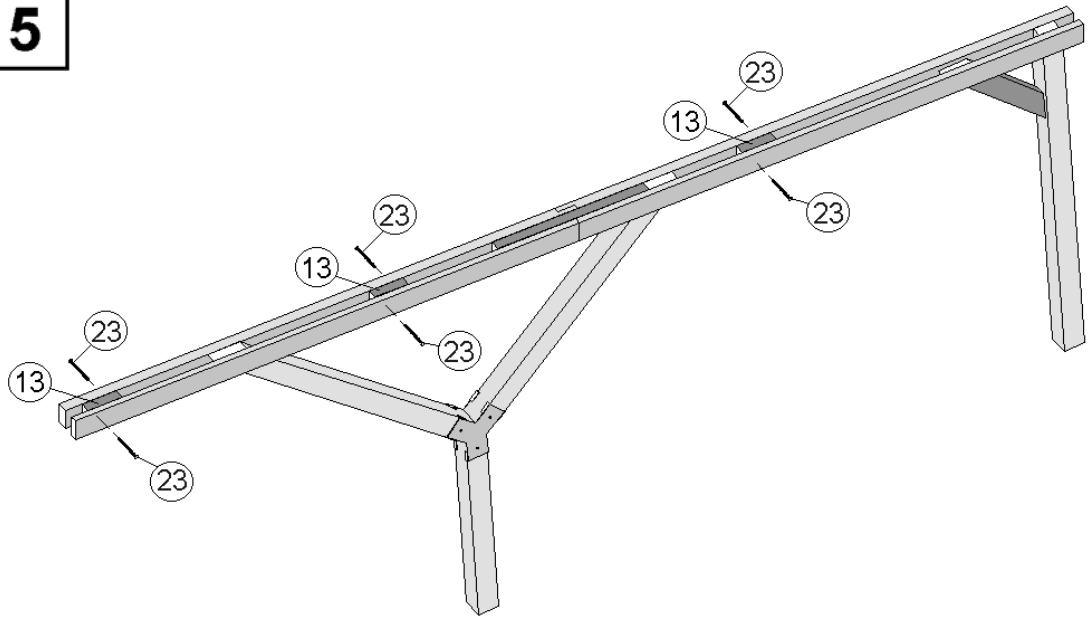

6

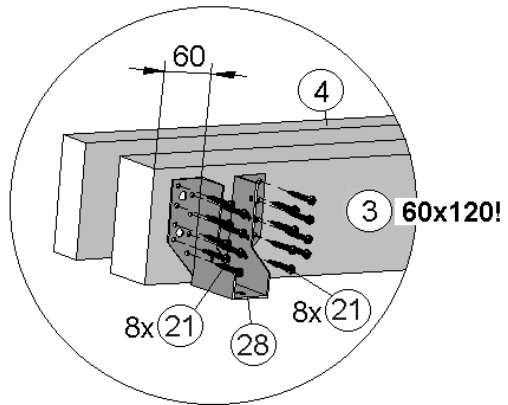
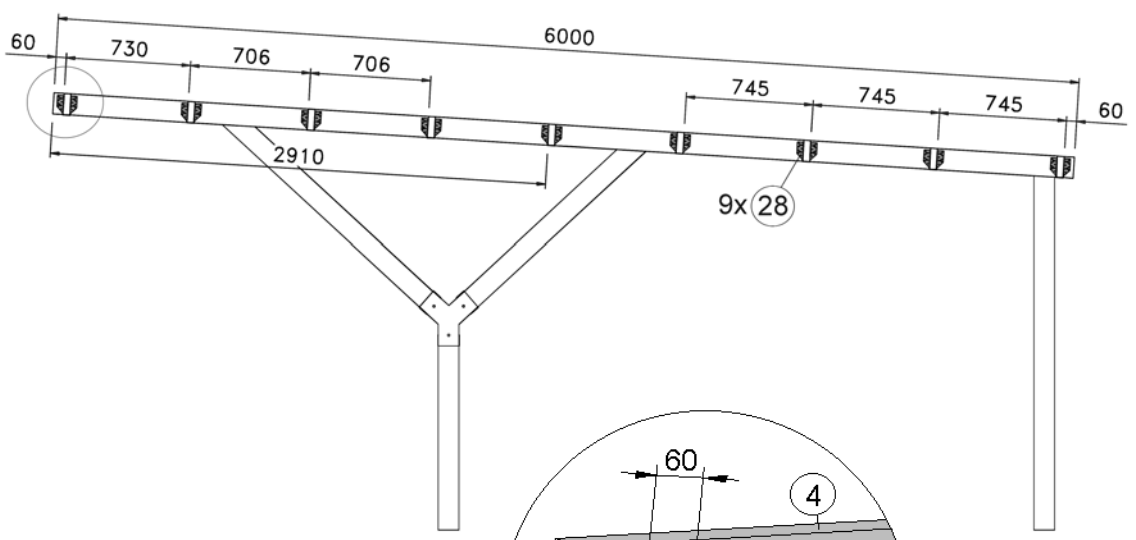

de	H-Anker
en	H anchor
fr	élément d'ancrage en
it	ancora ad

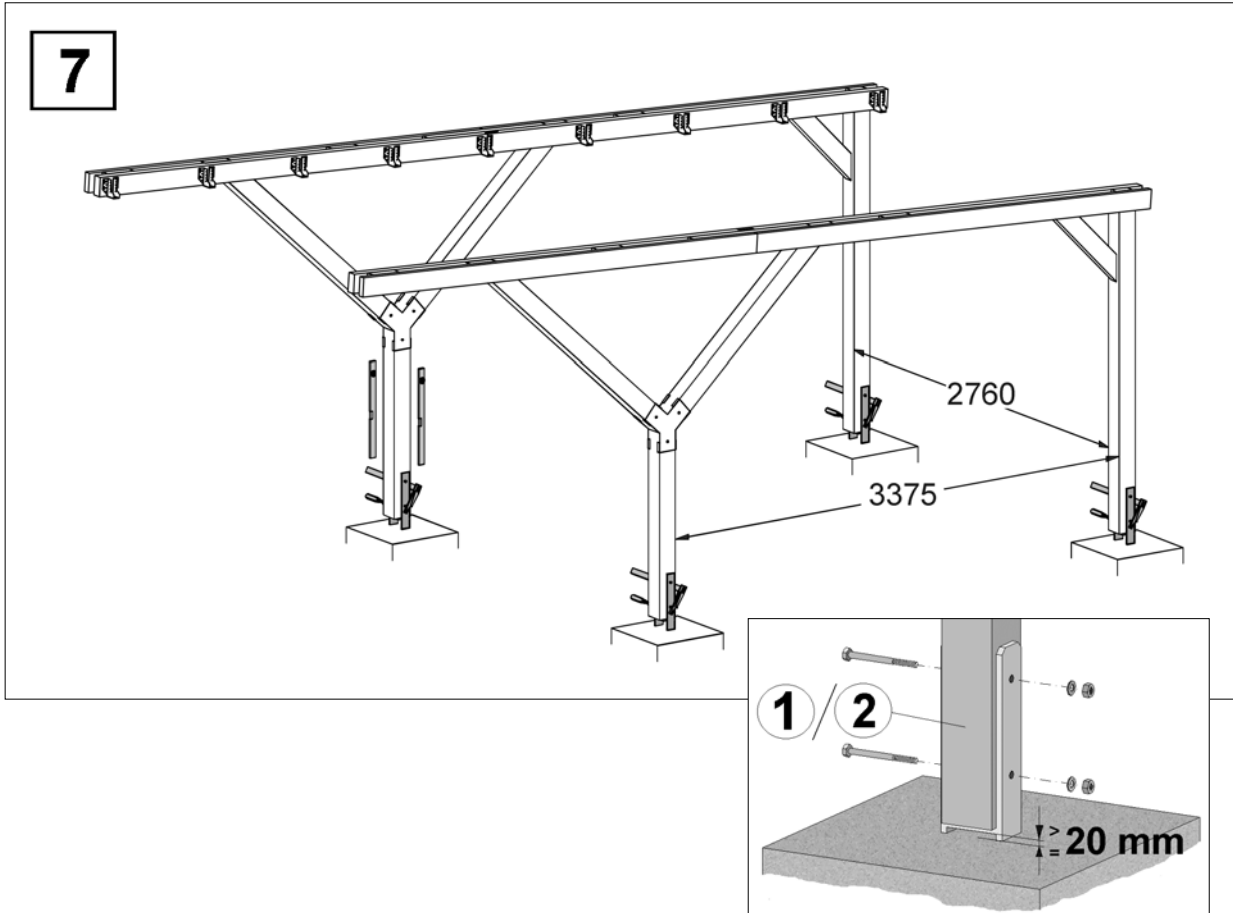
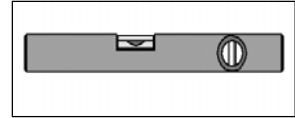
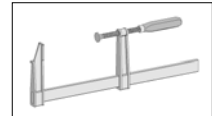
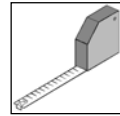
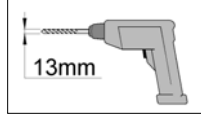
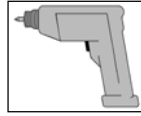

de	Frontansicht
en	Front view
fr	vue de devant
it	vista frontale

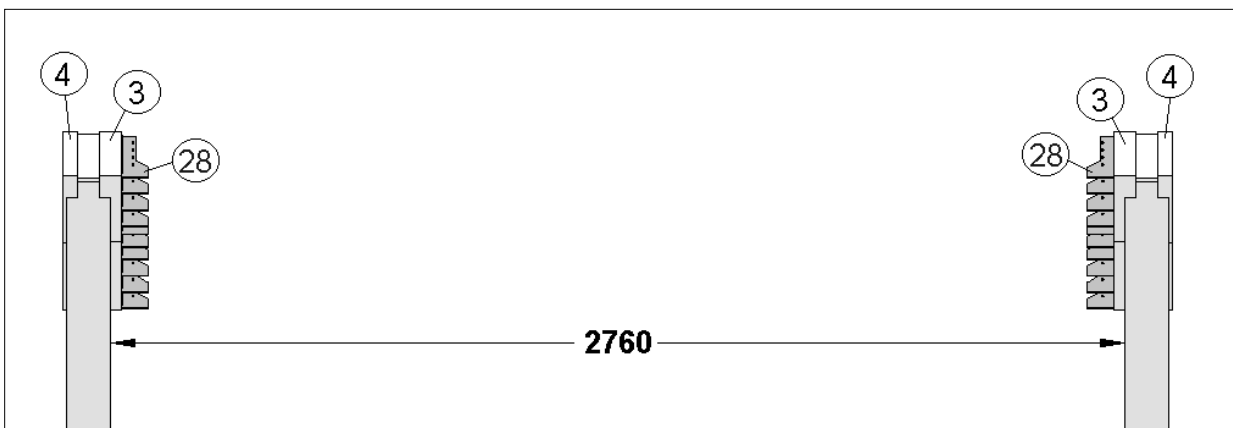

de	Sparren
en	Rafter
fr	chevron
it	travetto

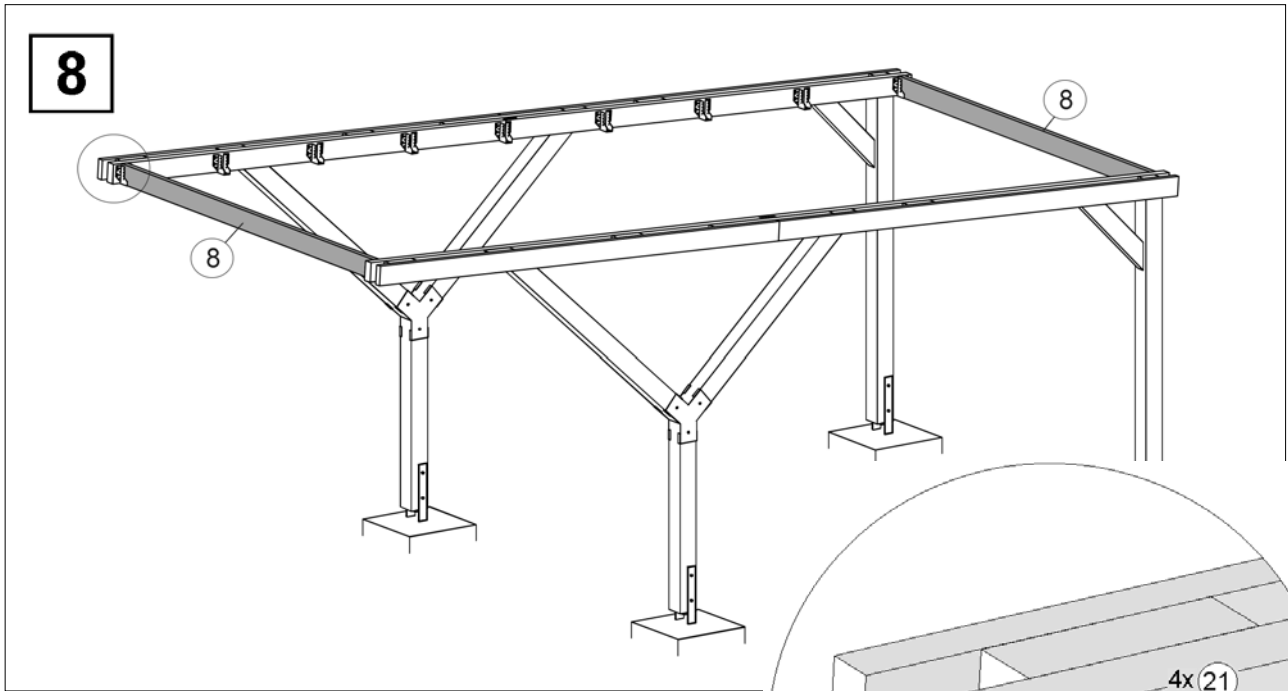
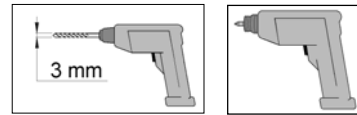

de	Kopfband
en	Strut
fr	bande de tête
it	nastro terminale

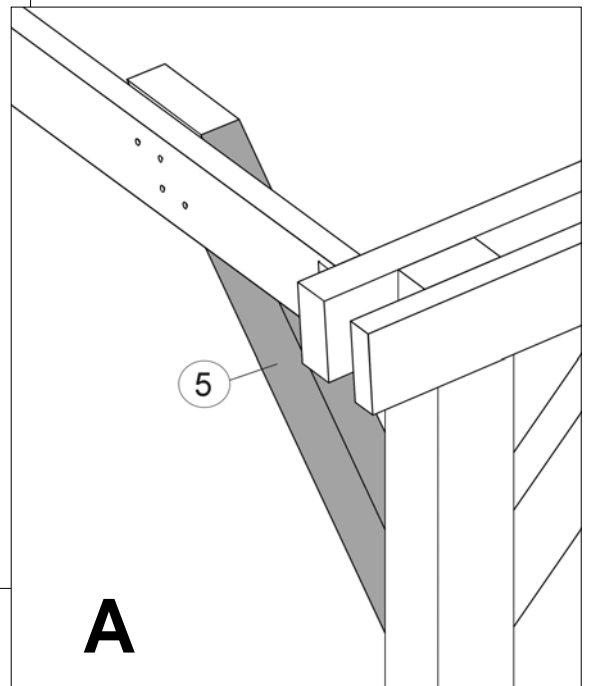
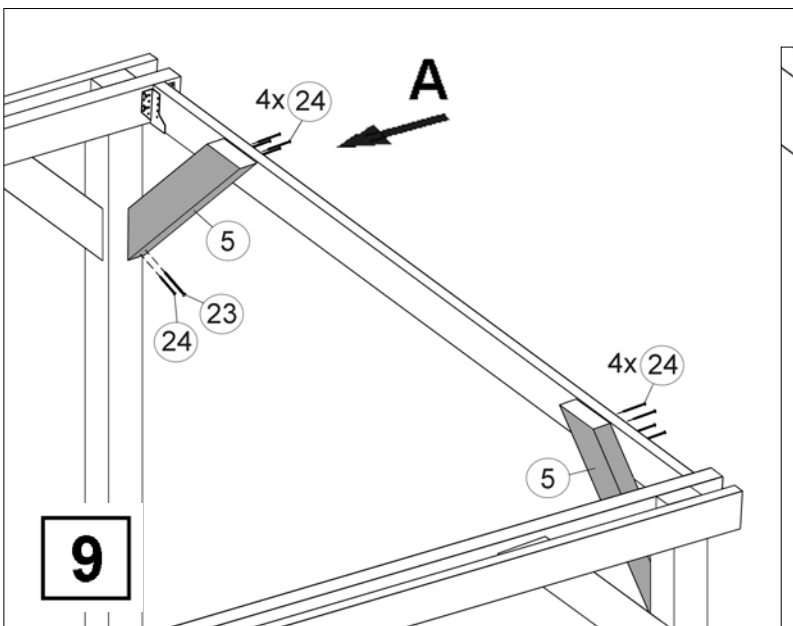

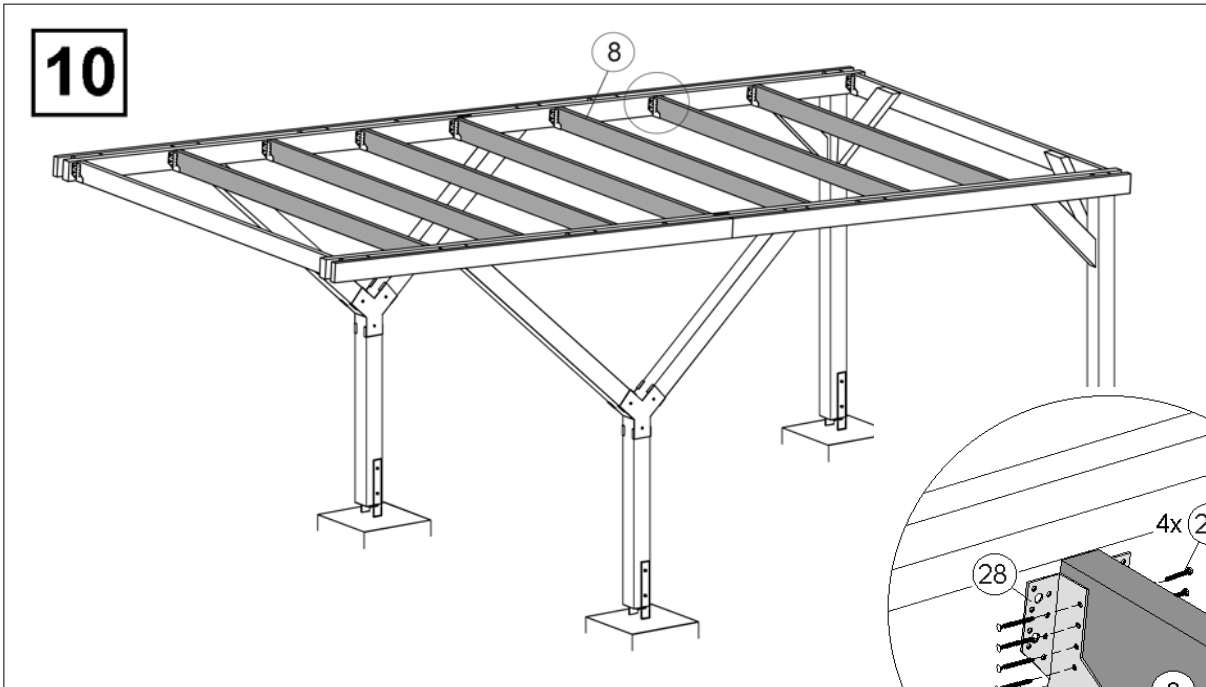
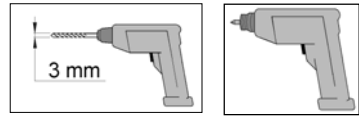

de	Diagonalstrebe
en	Diagonal strut
fr	Echarpe
it	Traversa diagonale

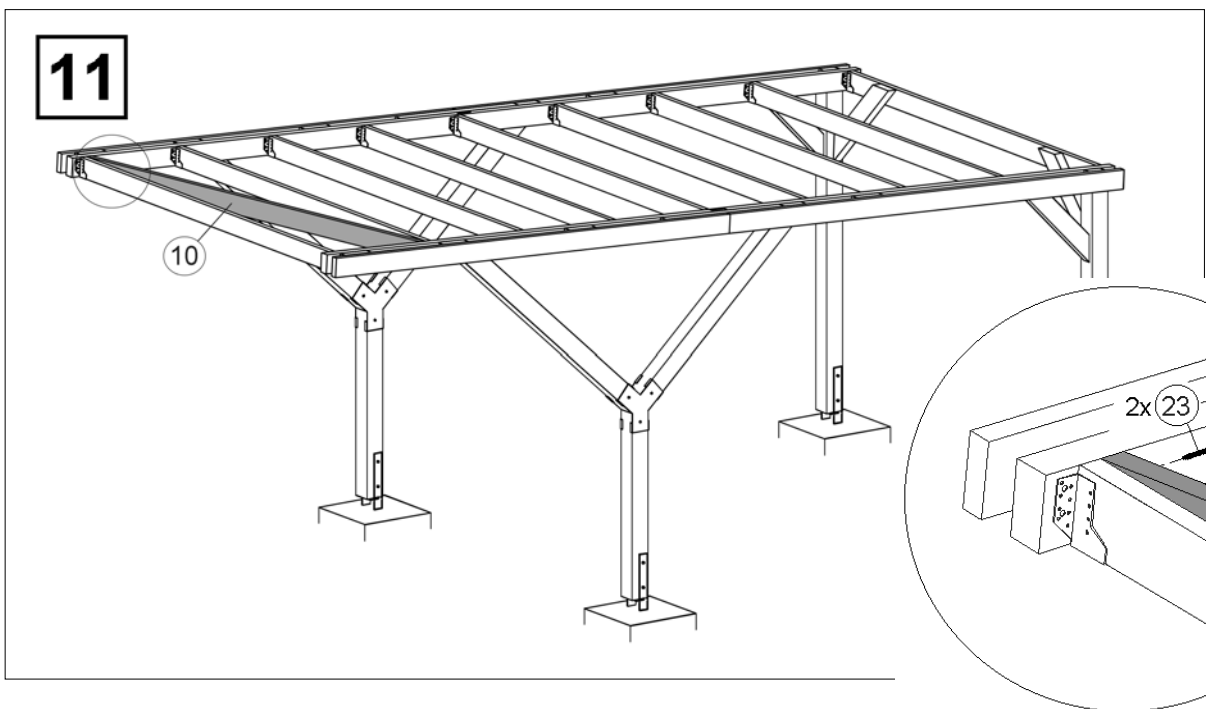
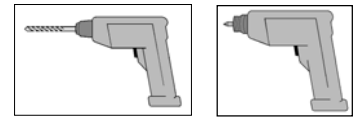

de	Blendbrett
en	Cover board
fr	Latte-cache
it	Visiera protettiva

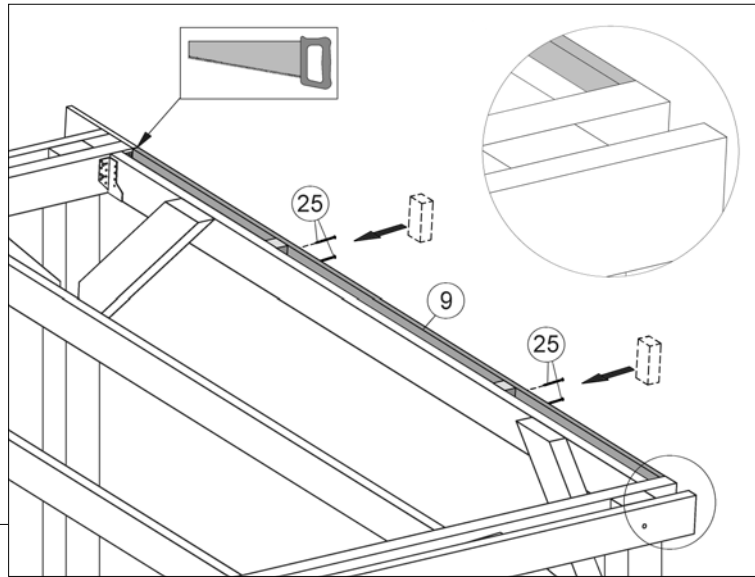
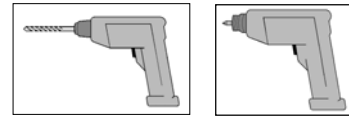

12

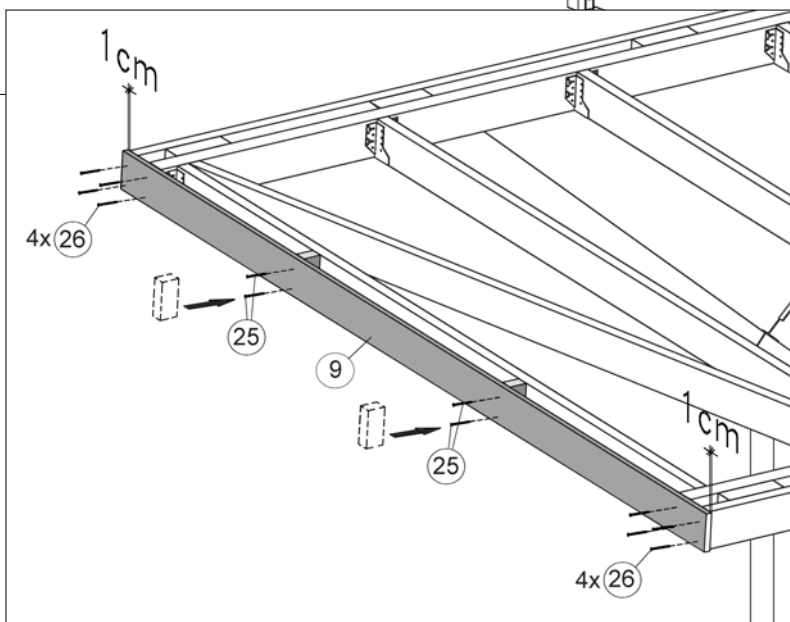
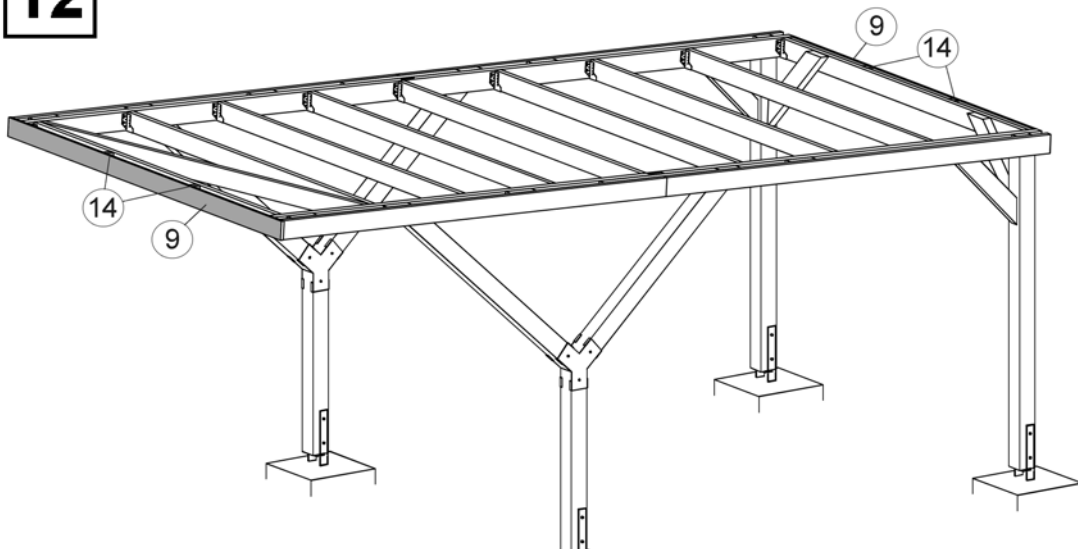

de	Dachplatte
en	Roof plate
fr	plaque de couverture
it	piastra del tetto

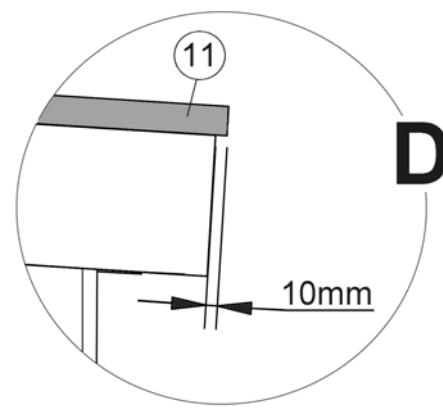
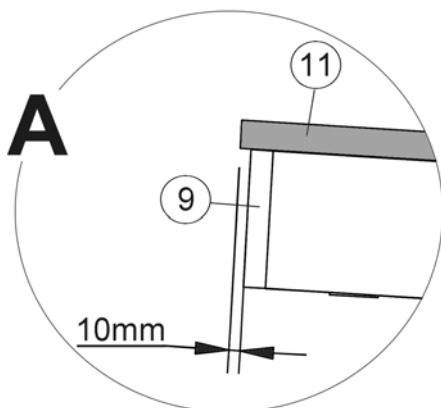
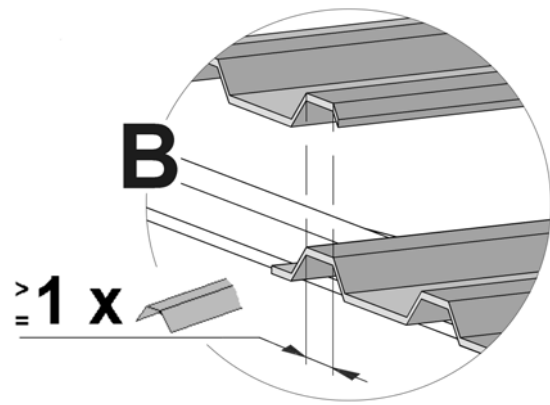
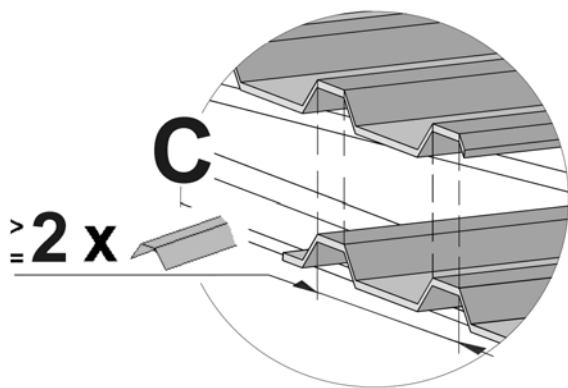
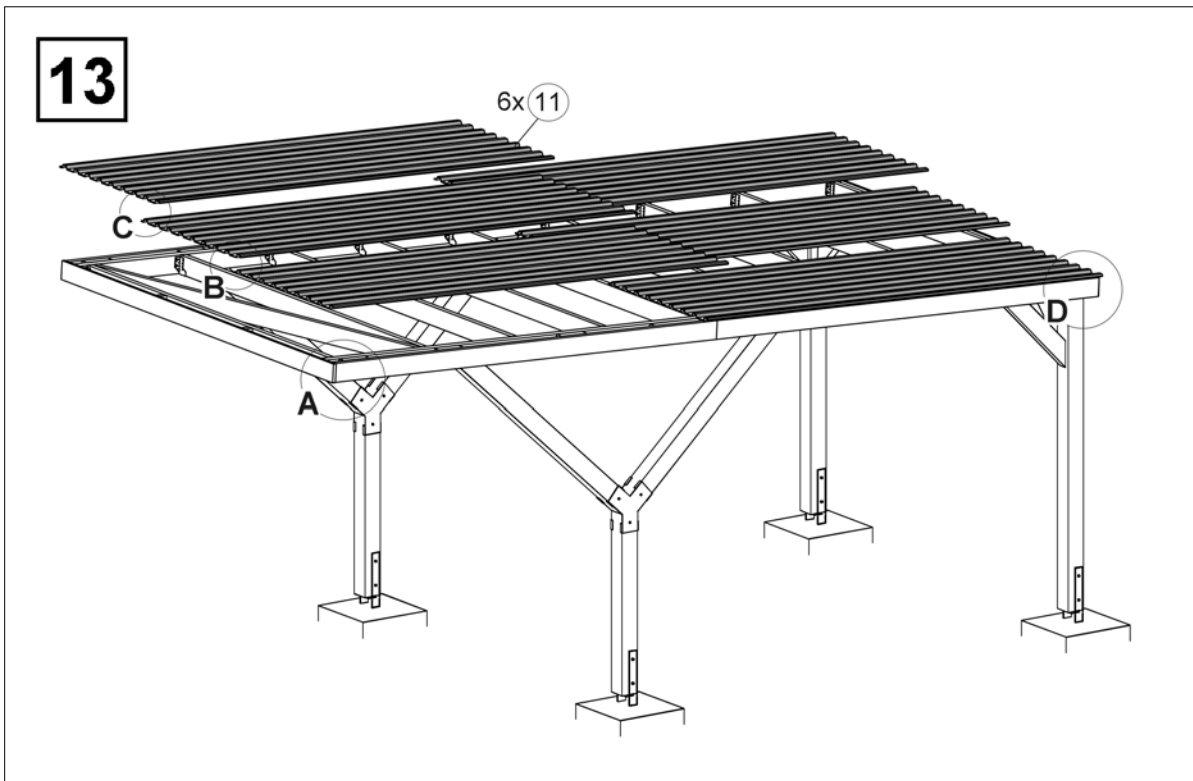
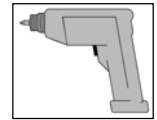
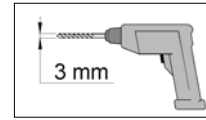
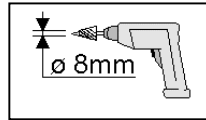

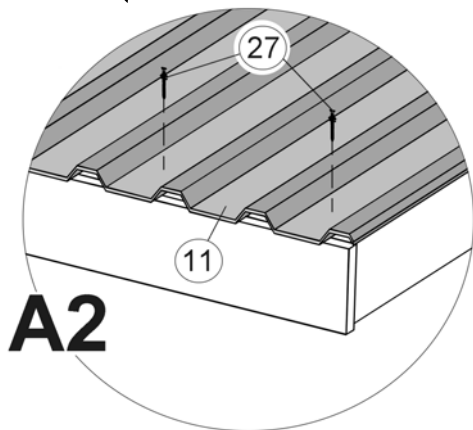
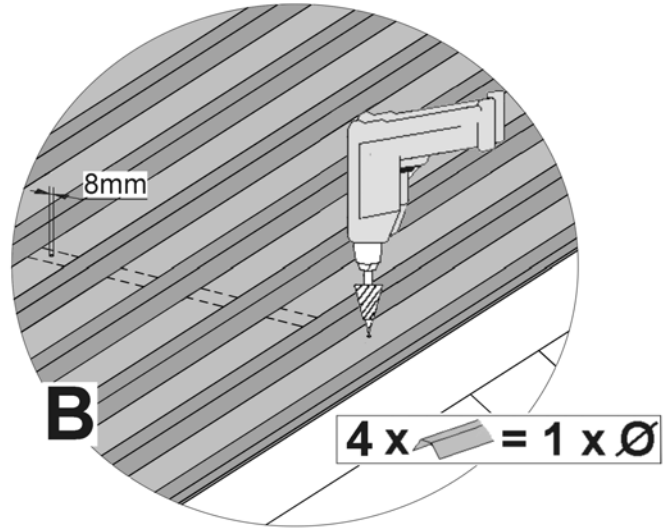
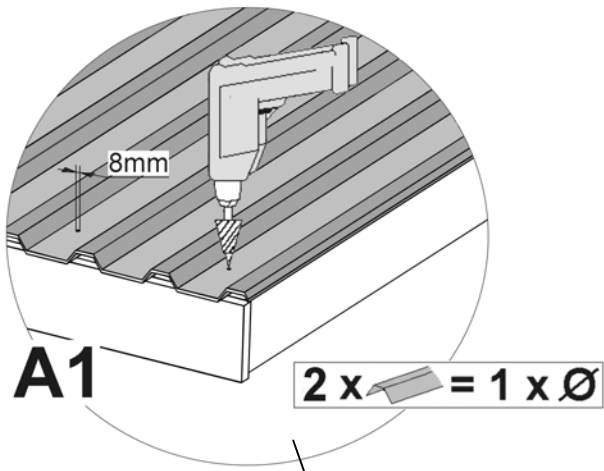
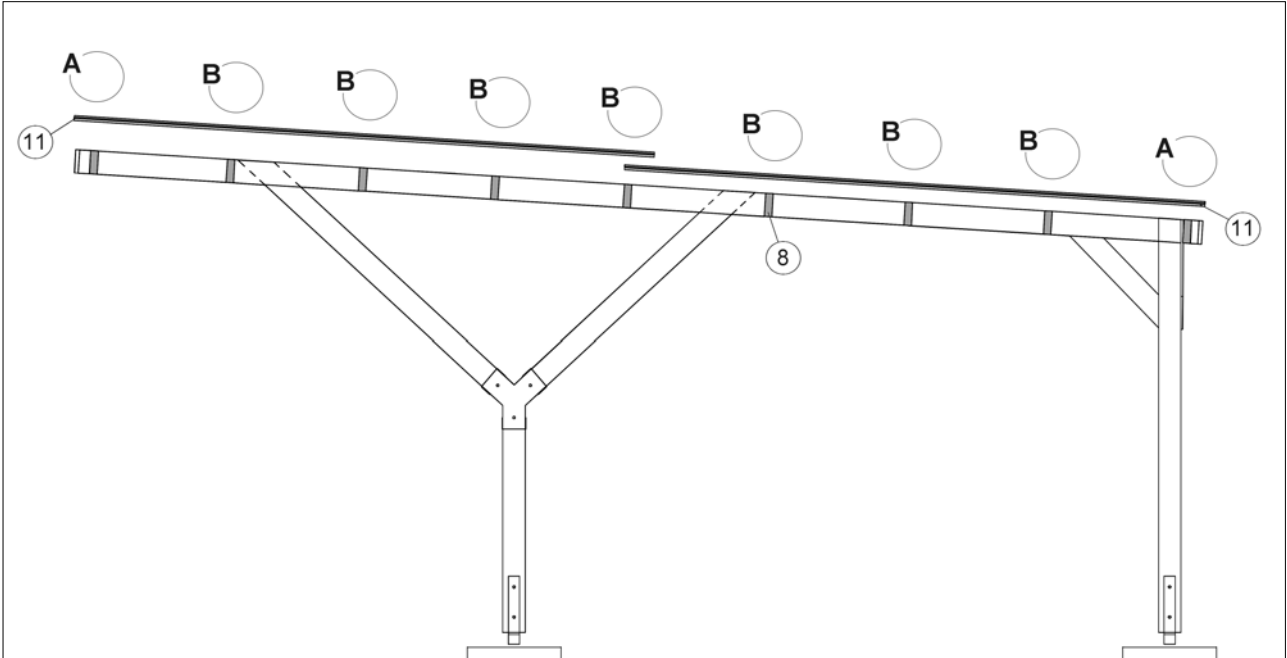
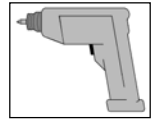
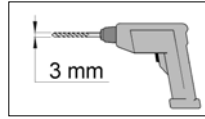
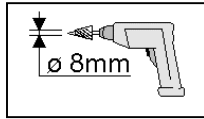

Art.-Nr.: 612.6060.00.00

de	Pfosten
en	Stud
fr	poteau
it	montante

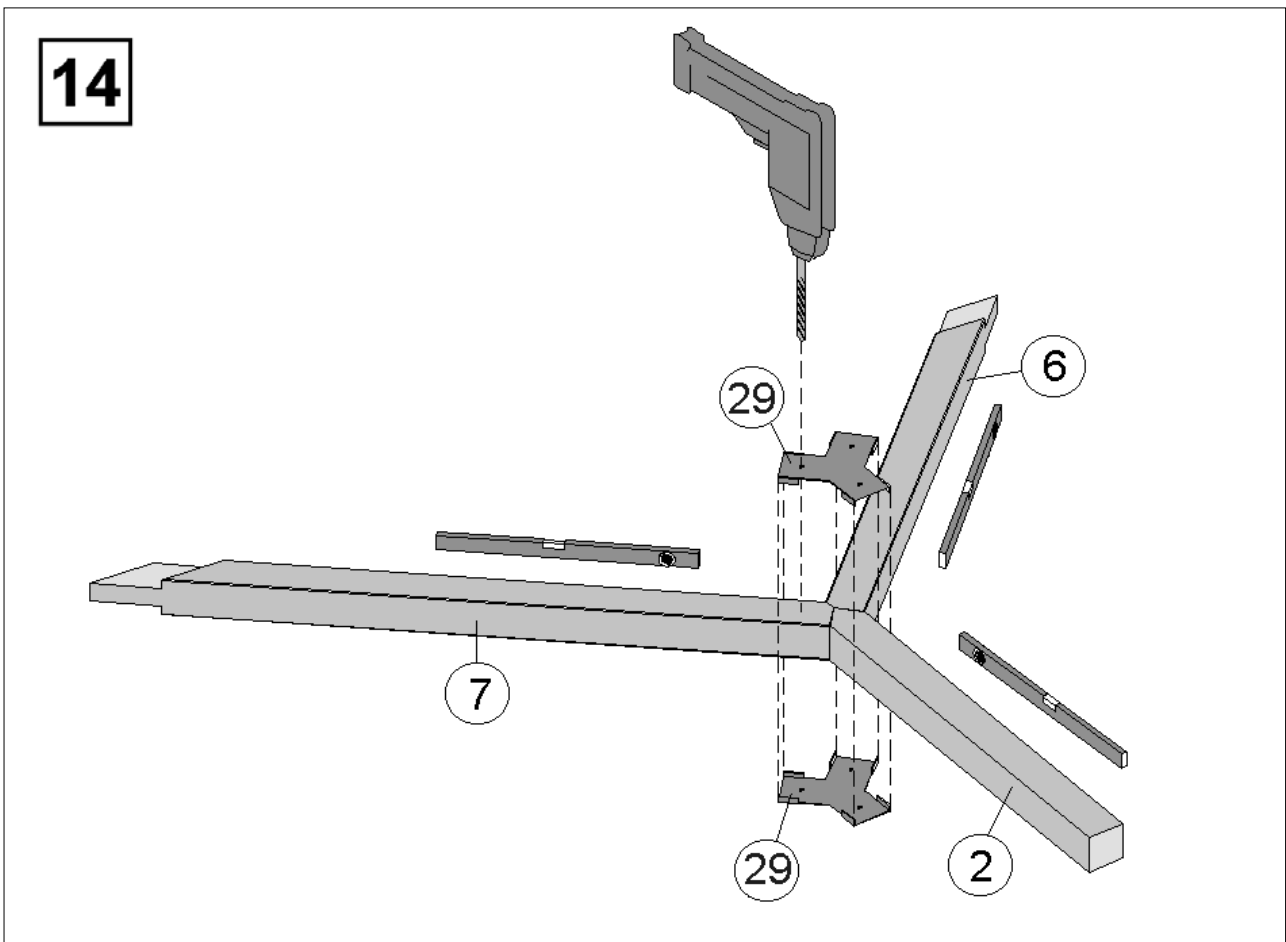
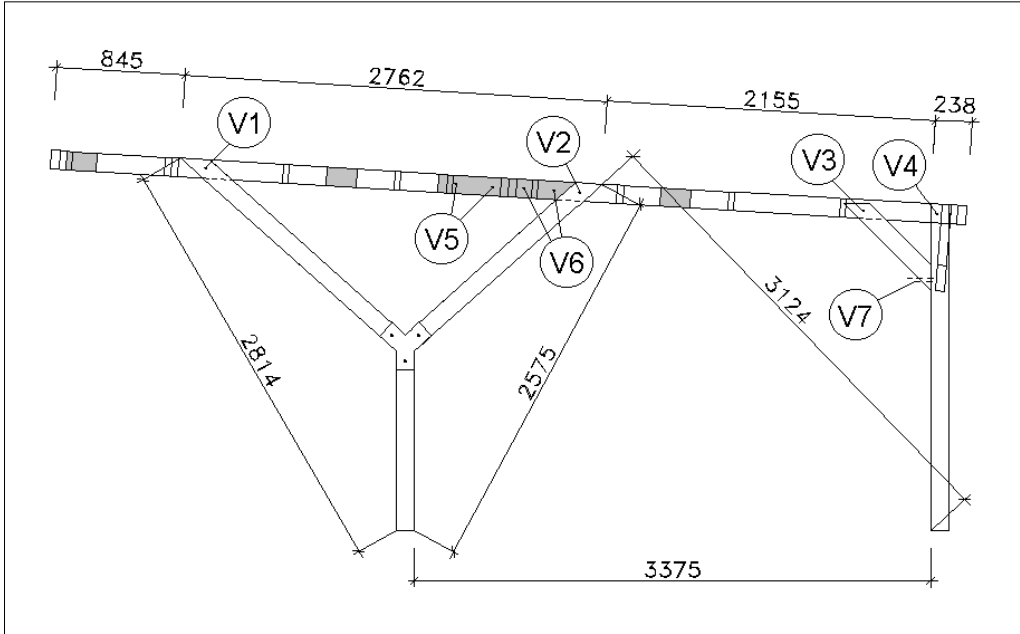
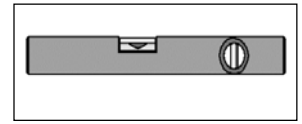
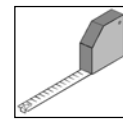
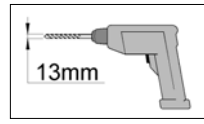
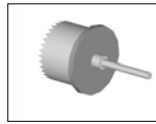

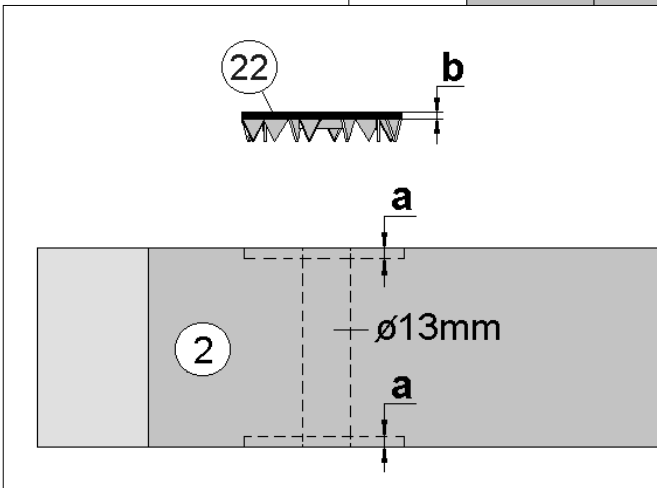
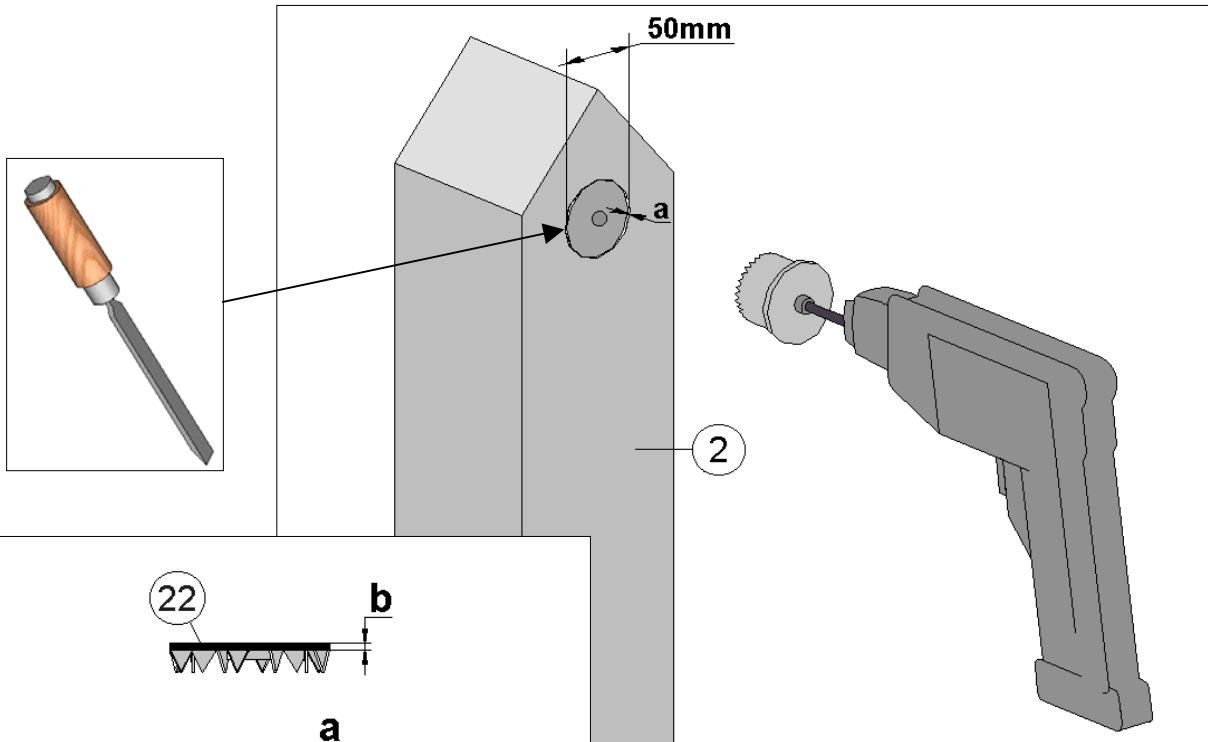
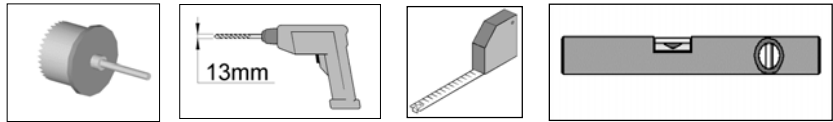

a=b

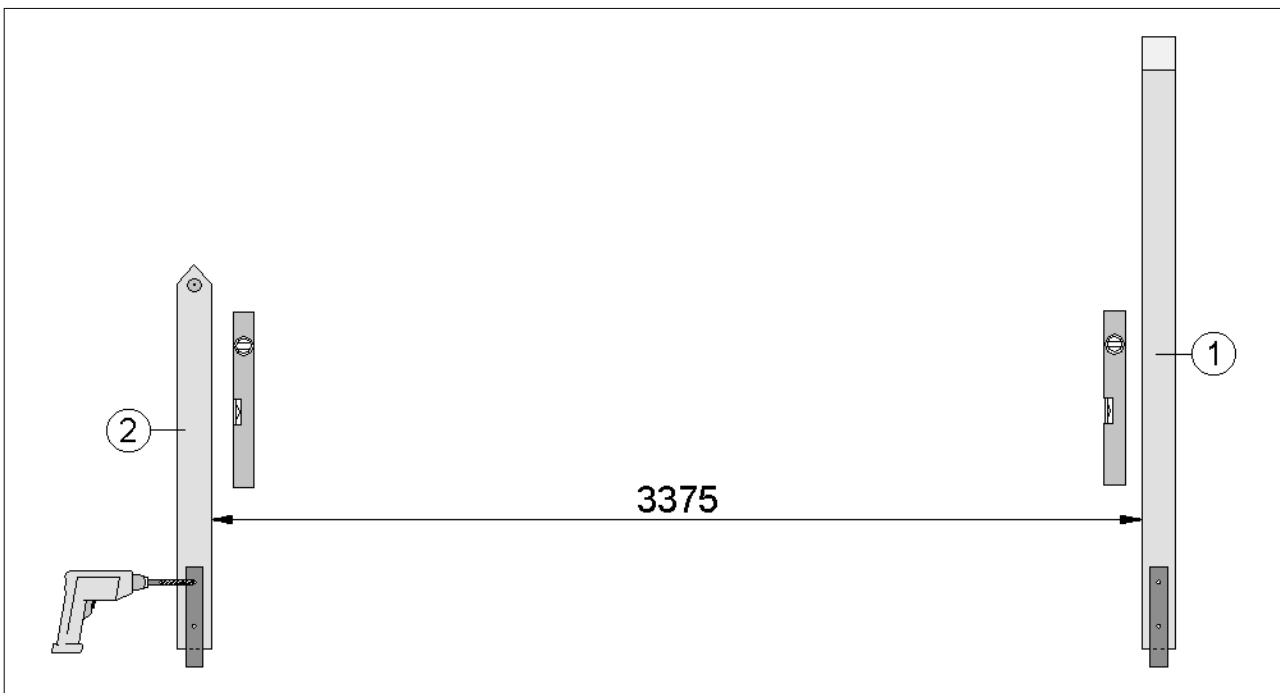

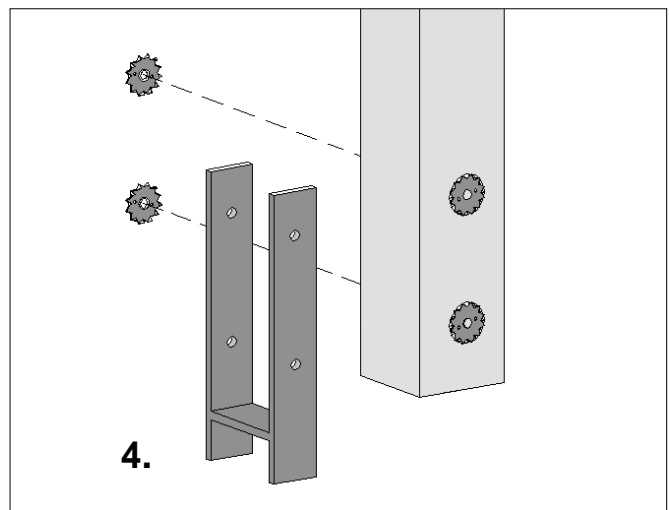
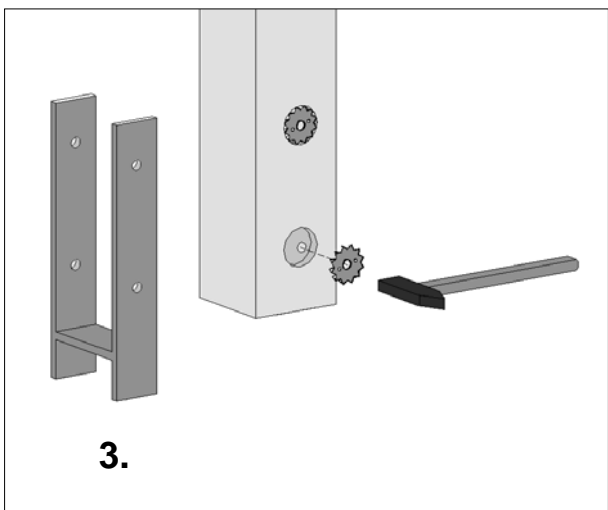
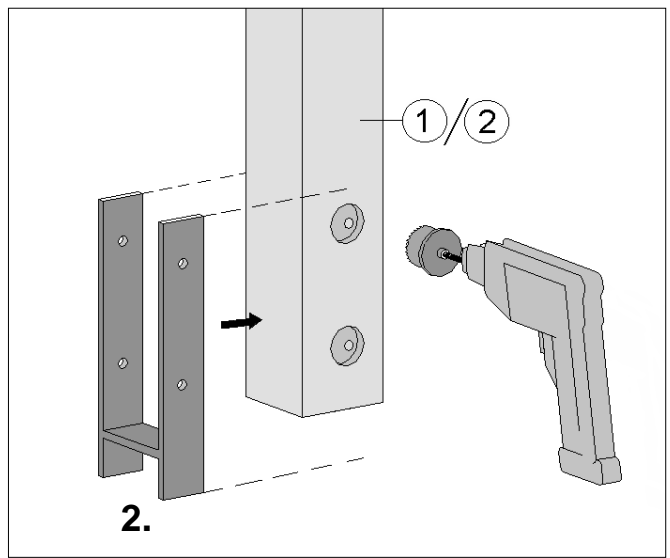
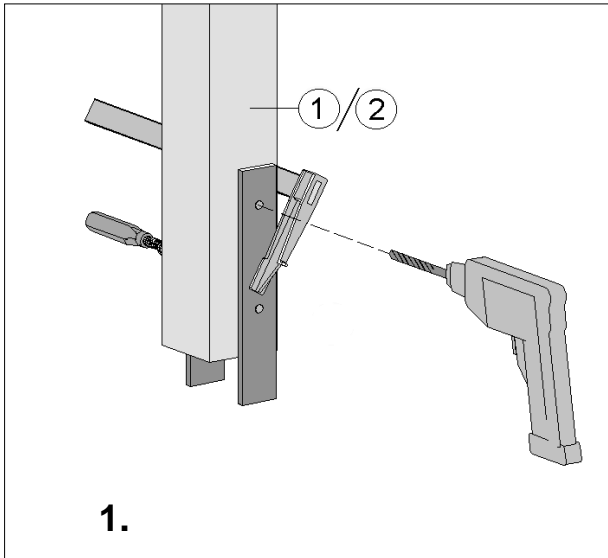
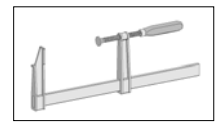
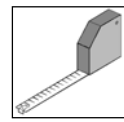
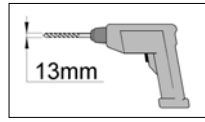
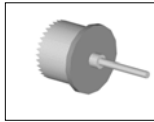

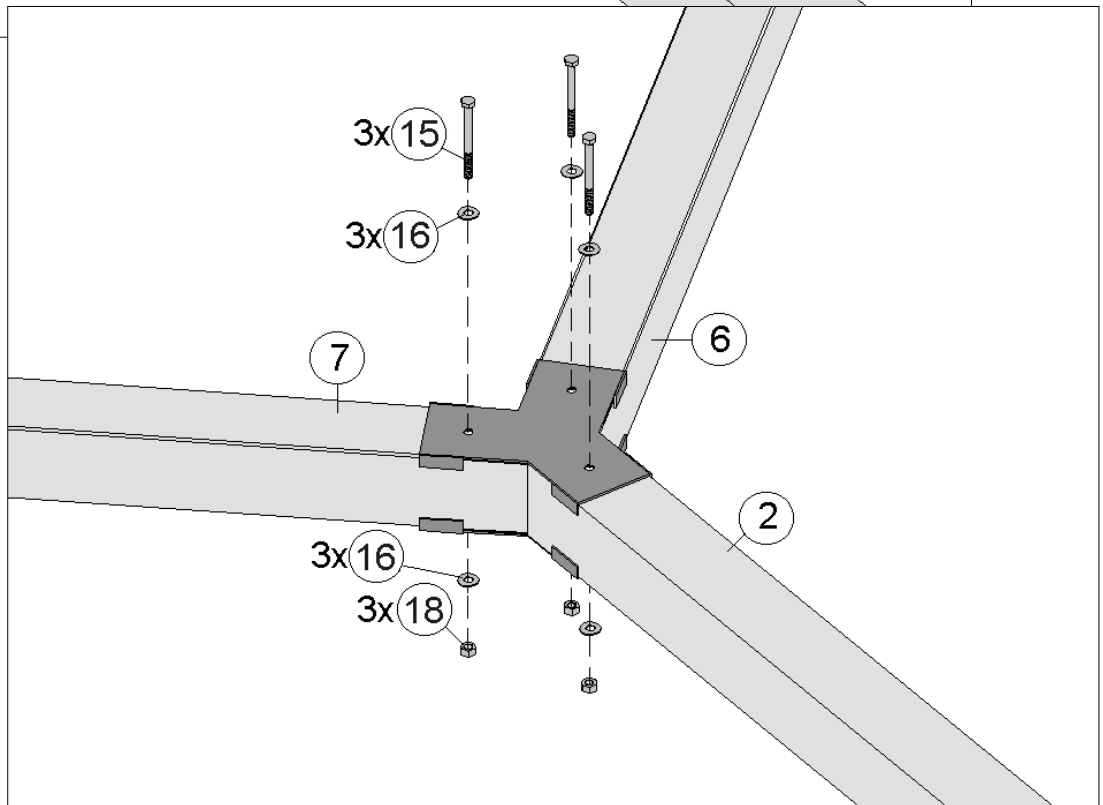
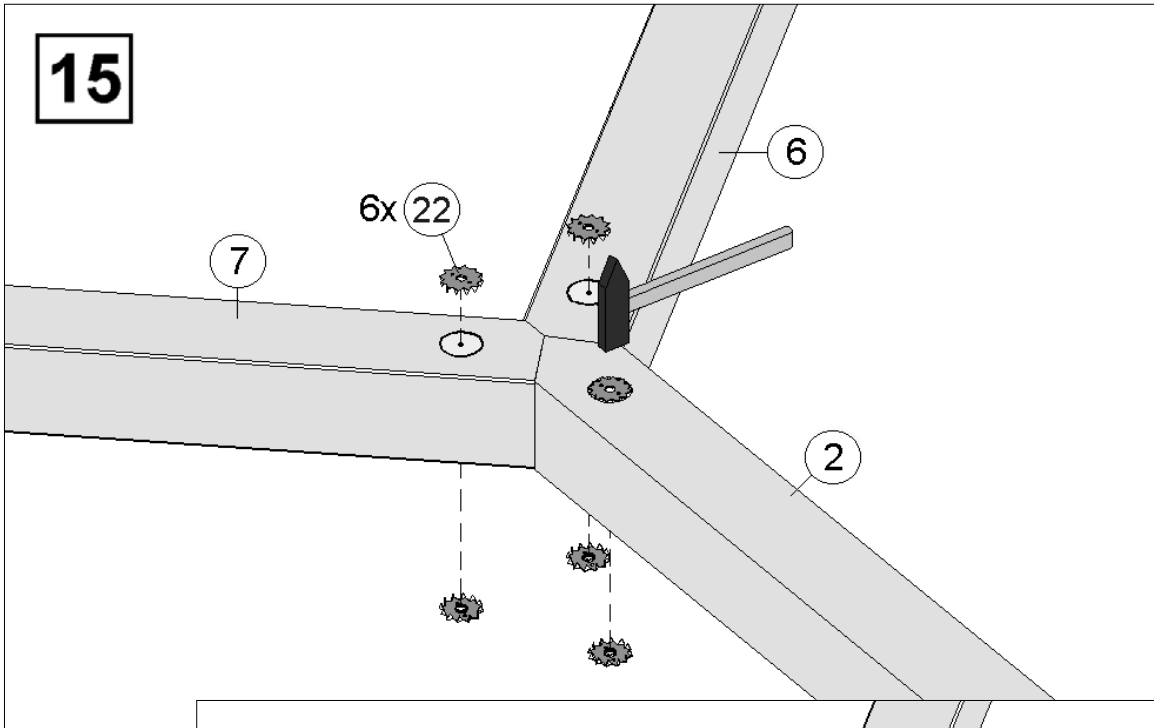
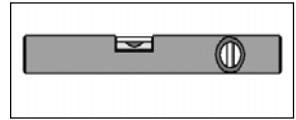
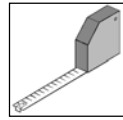
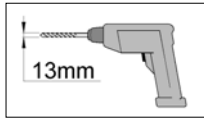
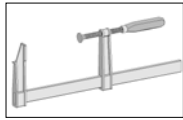

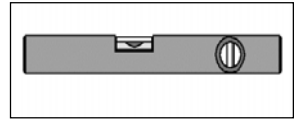
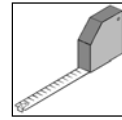
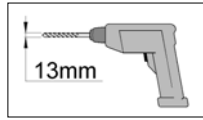
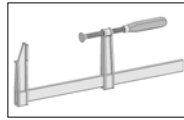

16

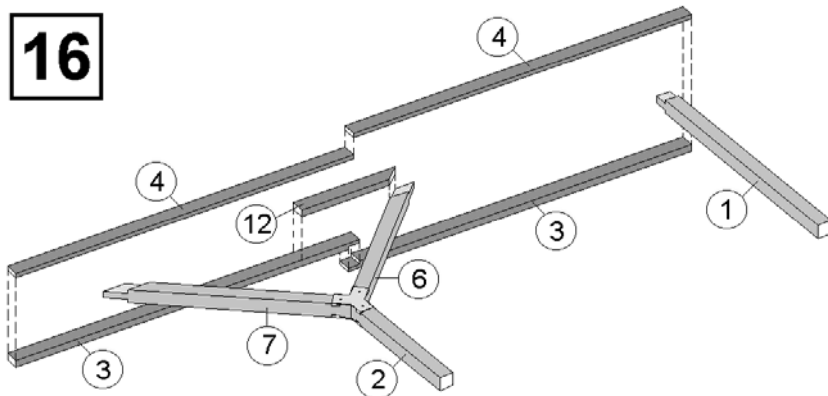

1x

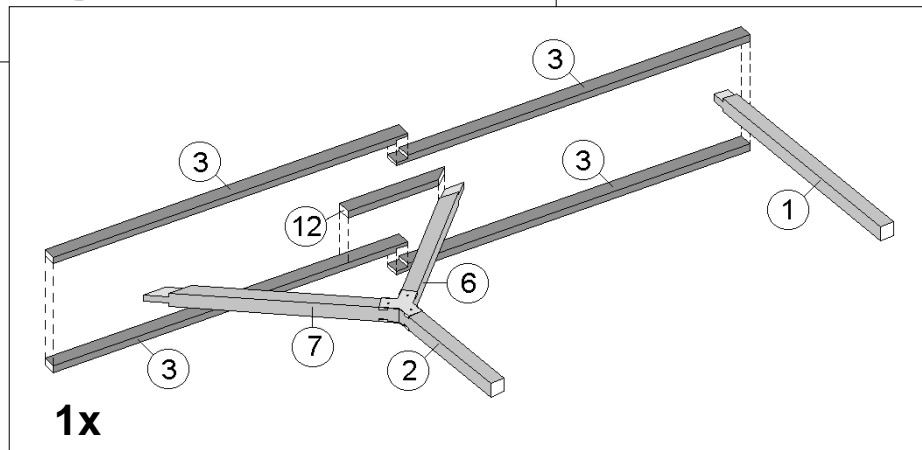

1x

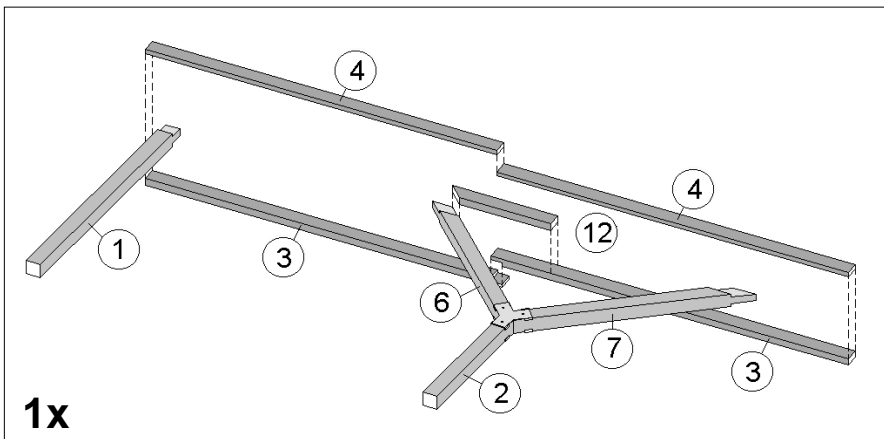

1x

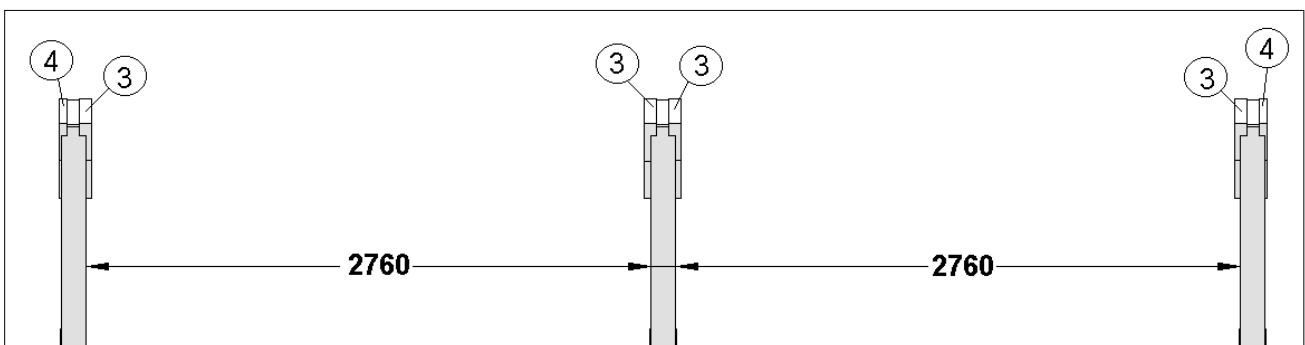

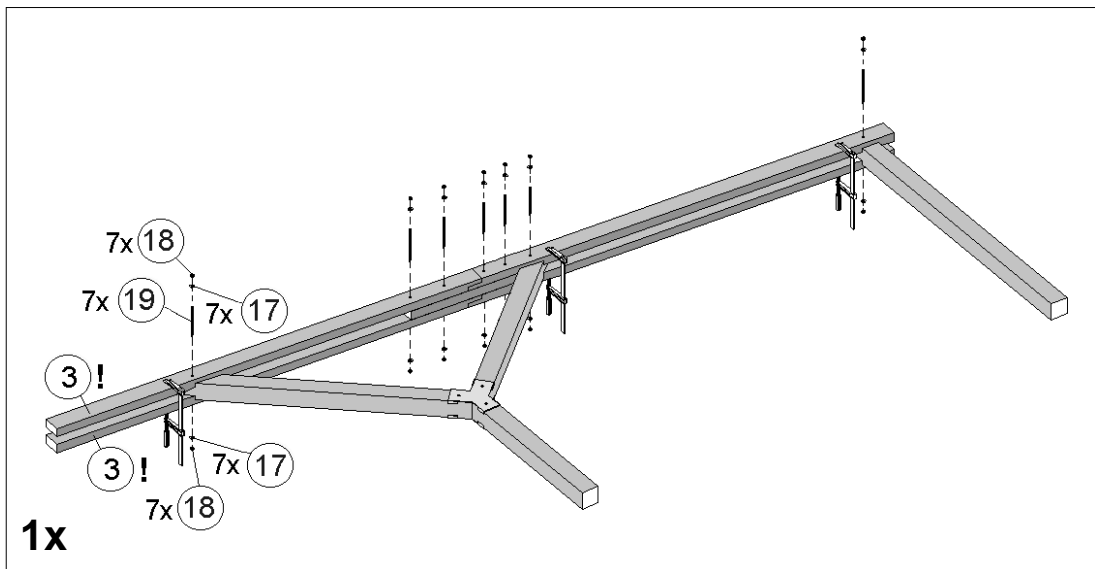
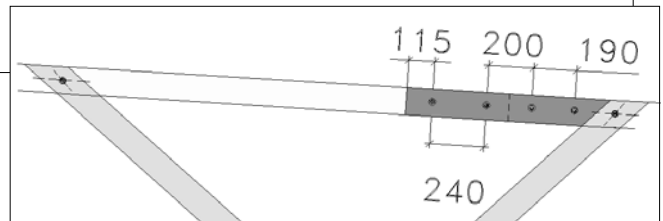
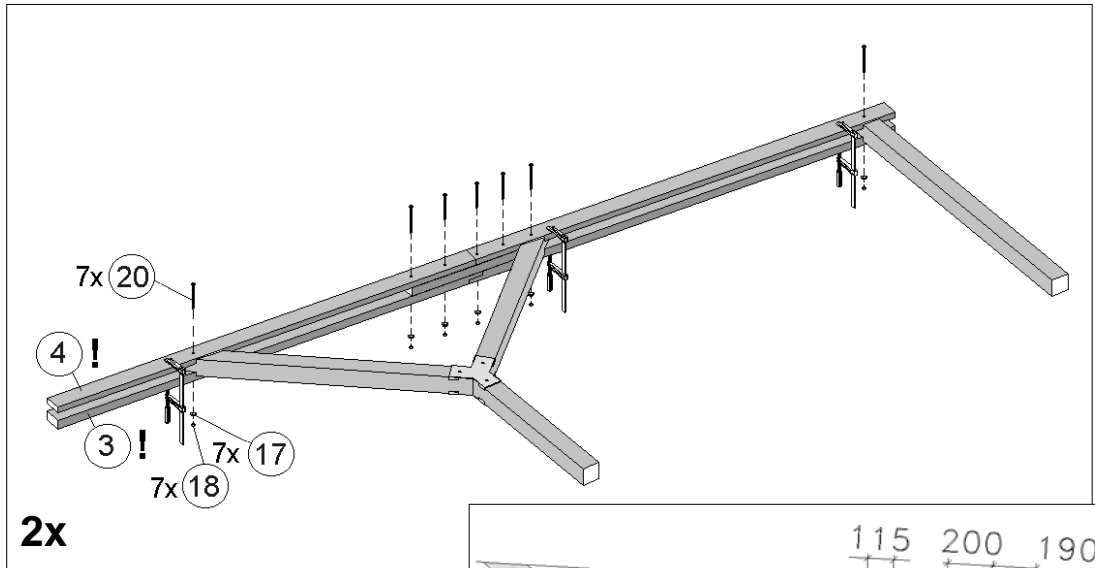
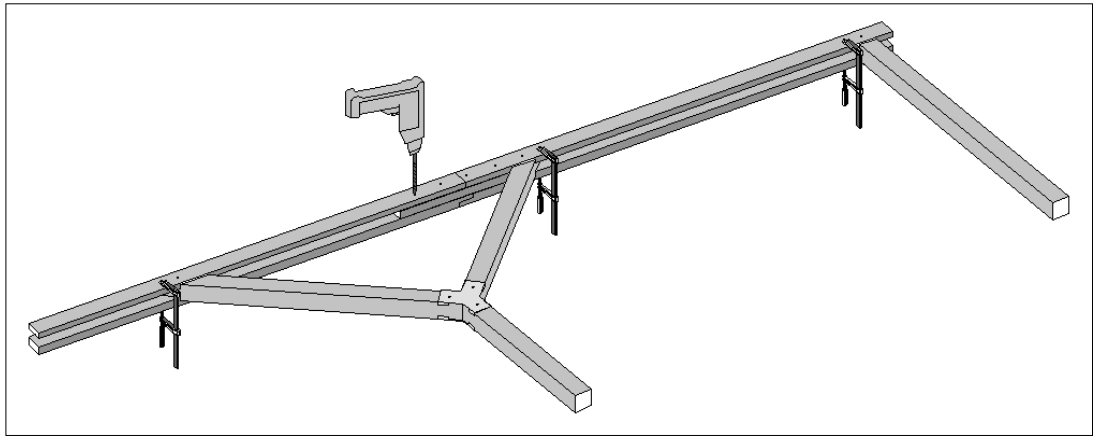
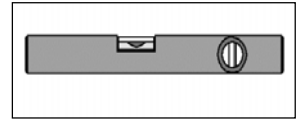
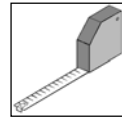
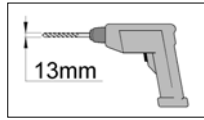
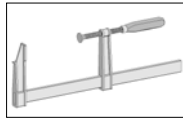

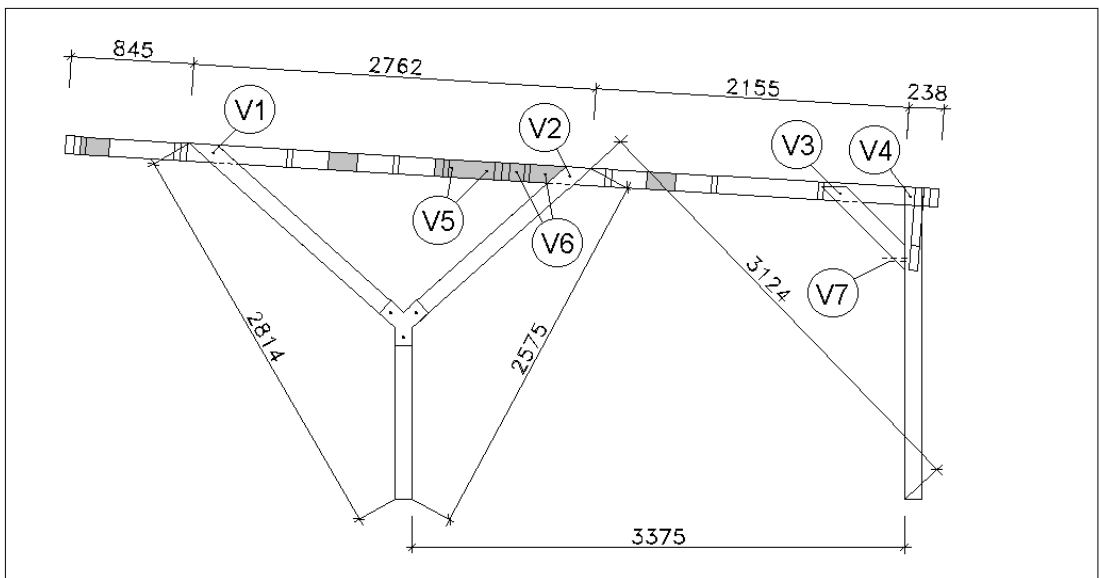
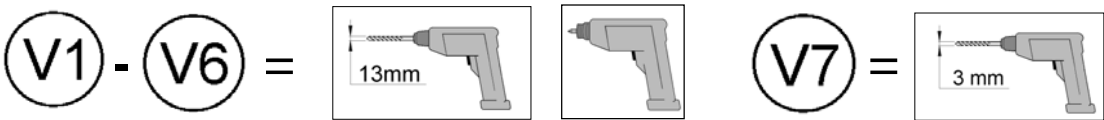
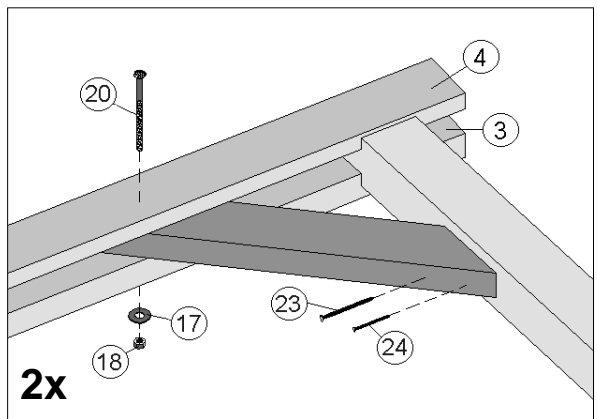
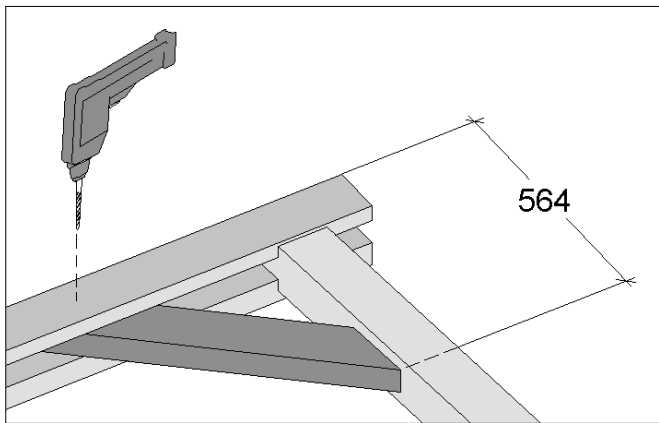
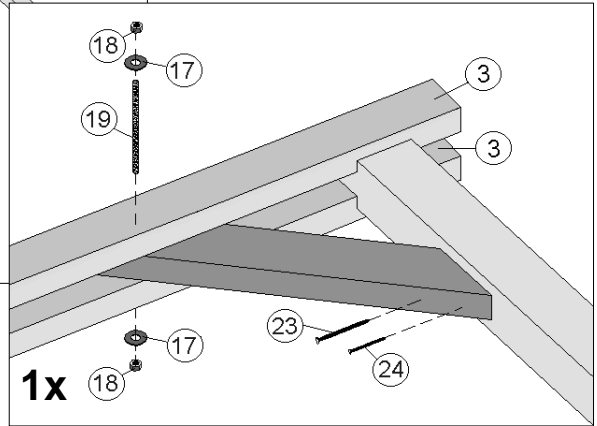
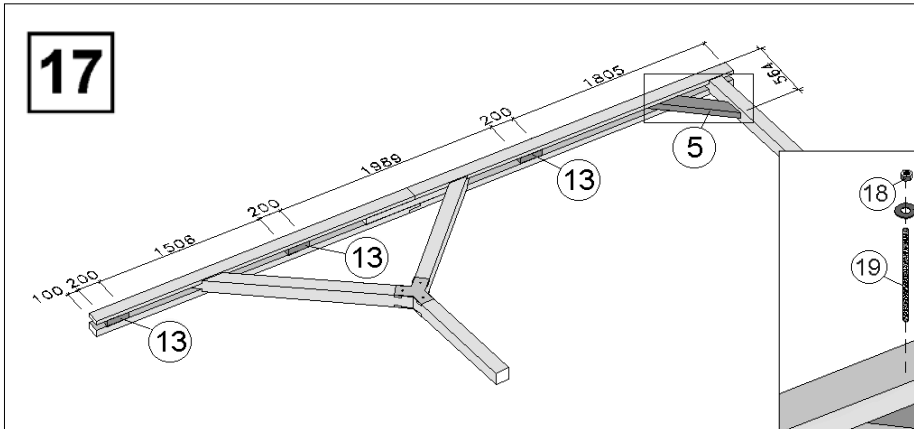
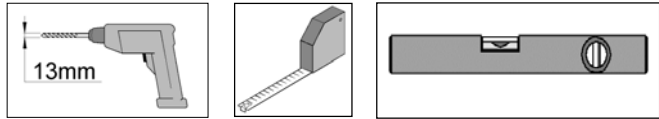

Technische Änderungen vorbehalten! Alle Maßangaben sind ca. Maße. © Copyright HRB 3662

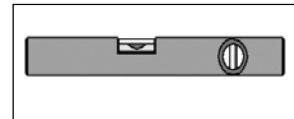
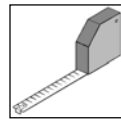
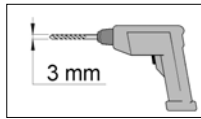

18

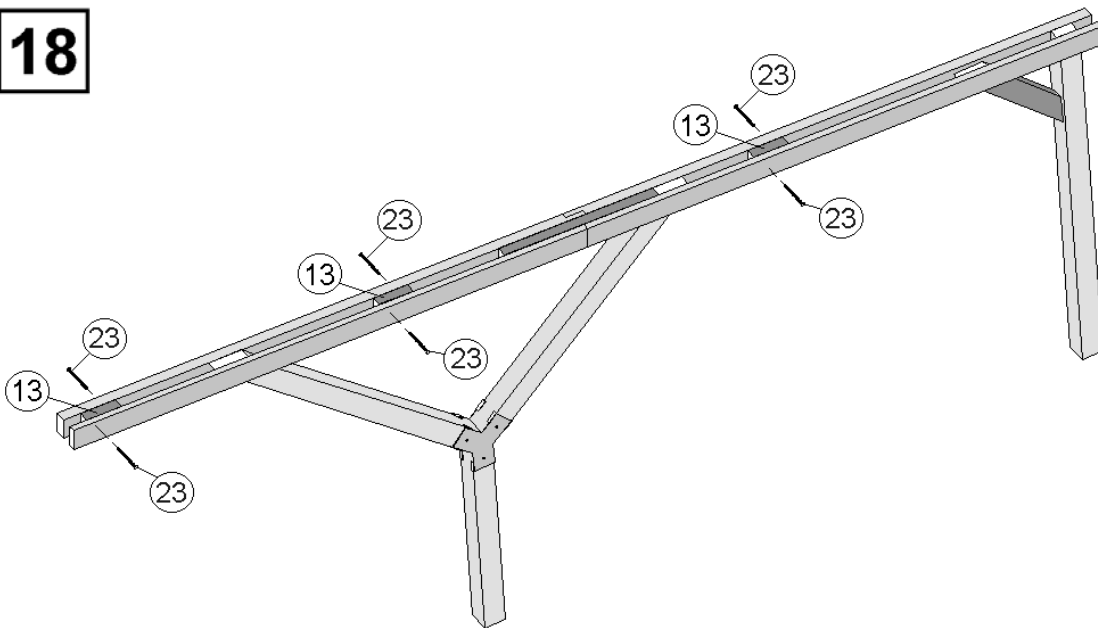

19

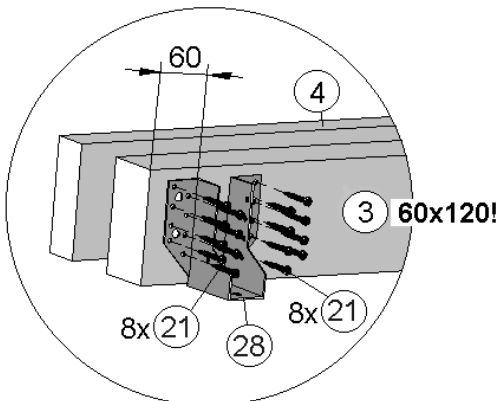
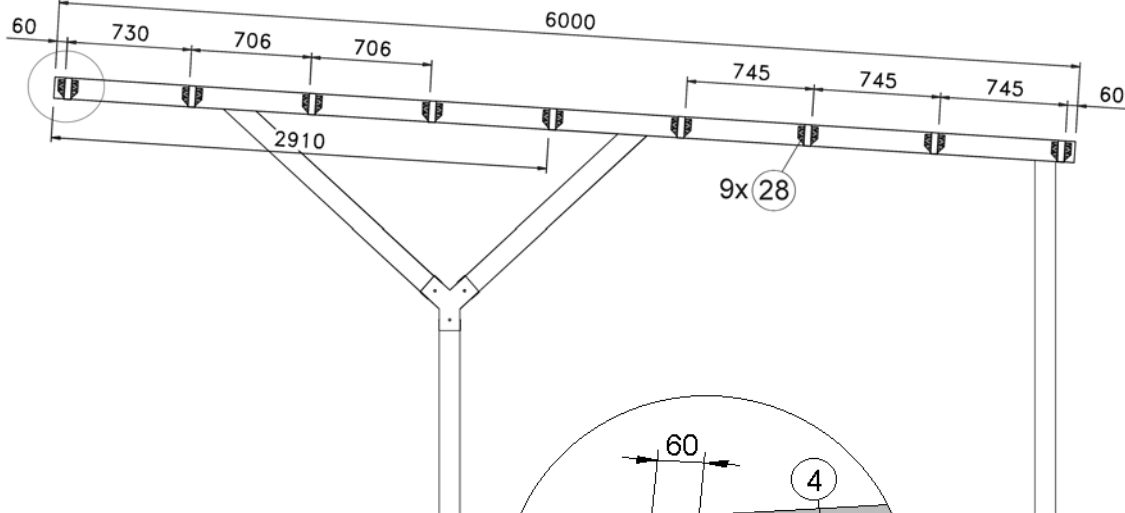

de	H-Anker
en	H anchor
fr	élément d'ancrage en
it	ancora ad

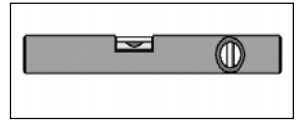
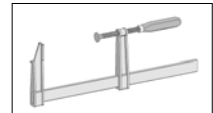
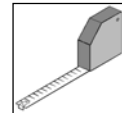
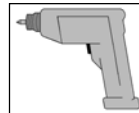
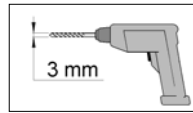

20

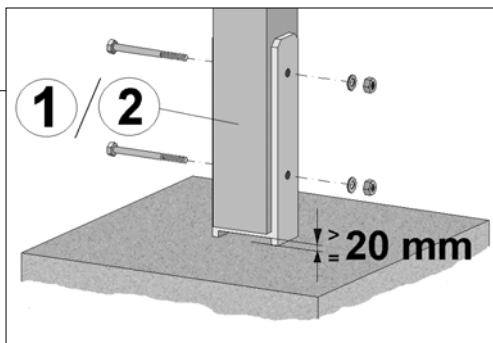
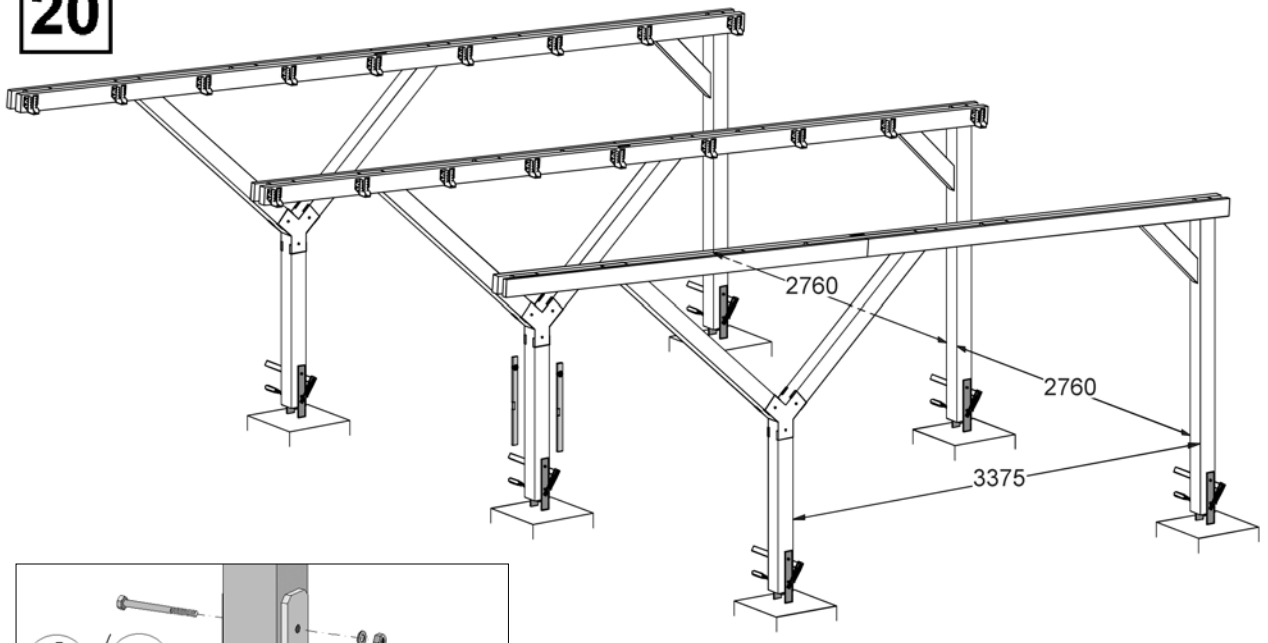

de	Frontansicht
en	Front view
fr	vue de devant
it	vista frontale

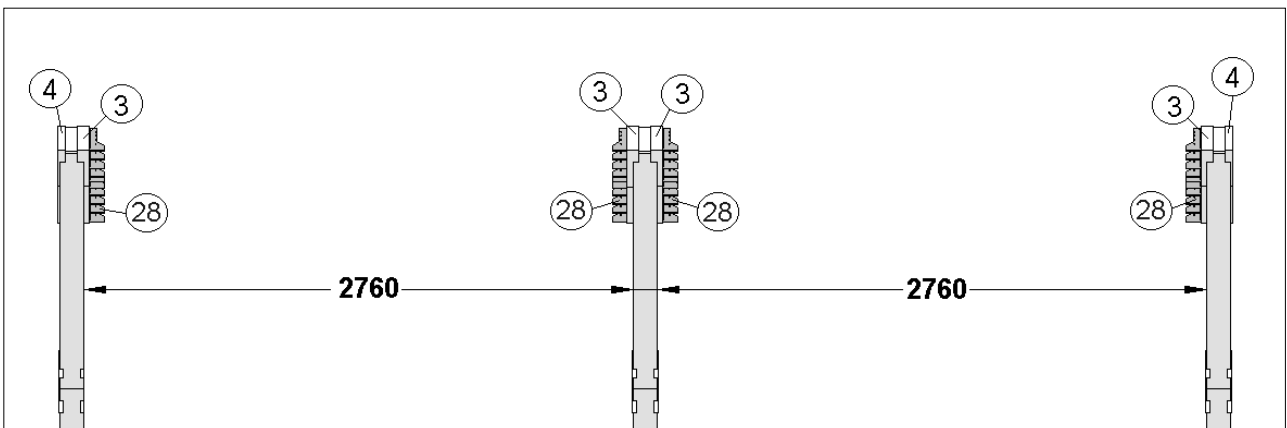

de	Sparren
en	Rafter
fr	chevron
it	travetto

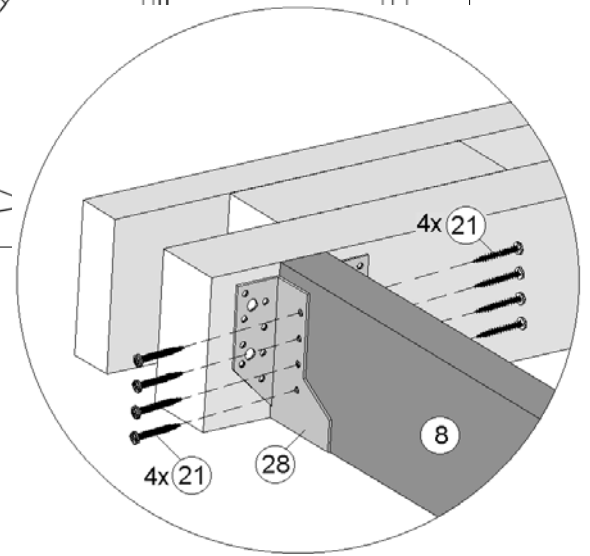
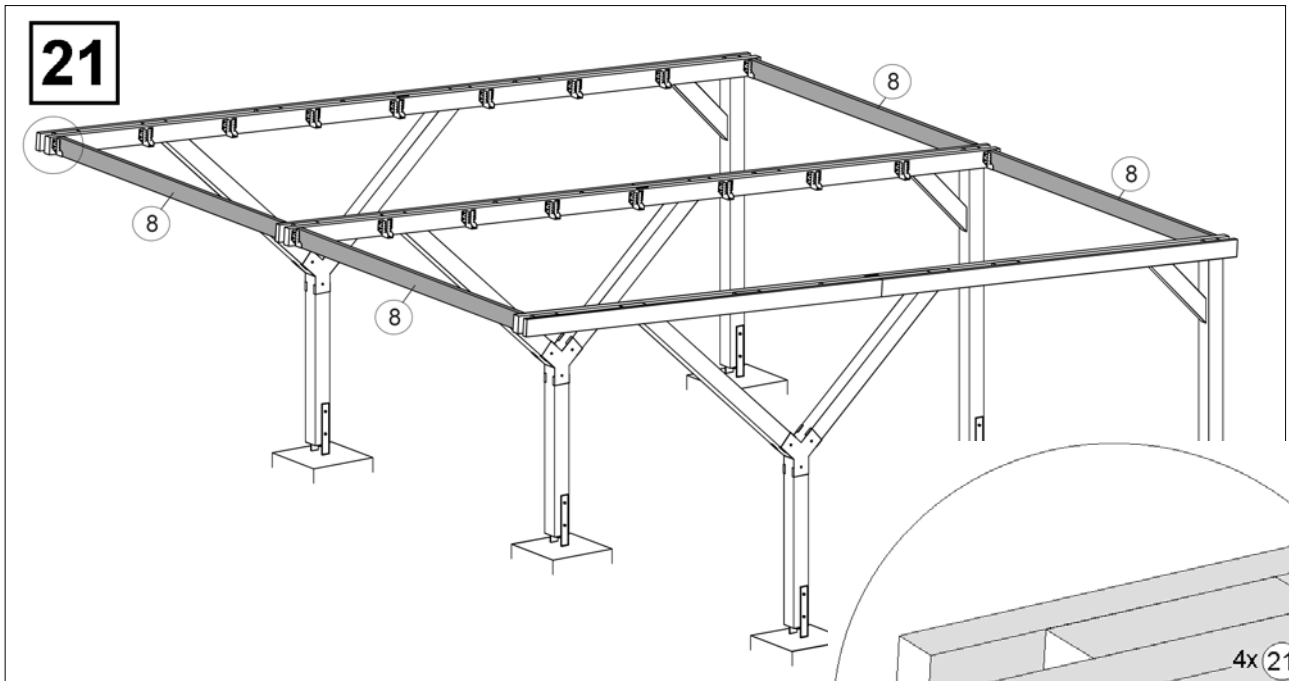
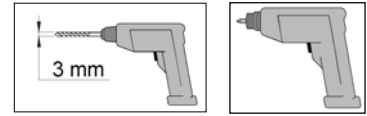

de	Kopfband
en	Strut
fr	bande de tête
it	nastro terminale

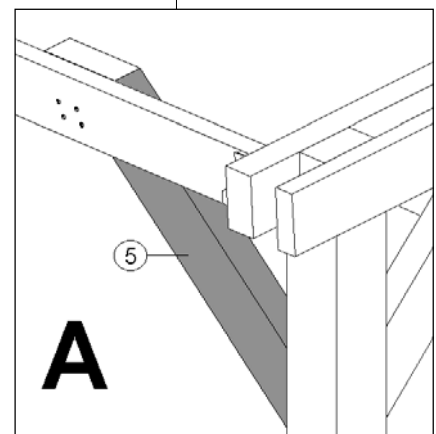
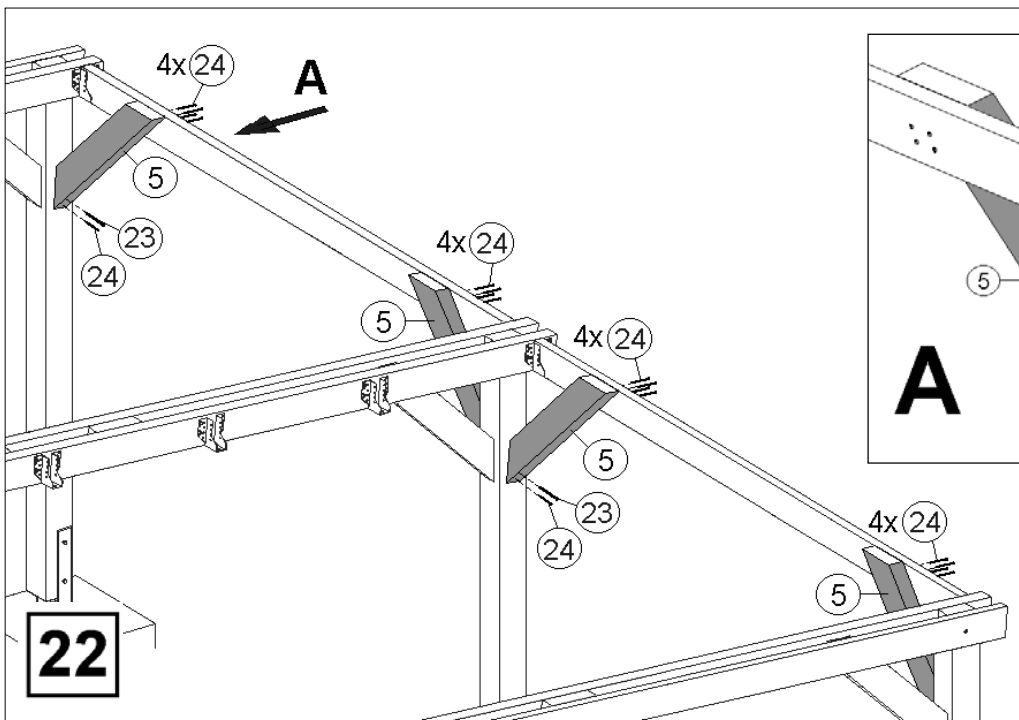
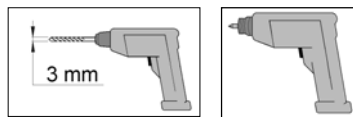

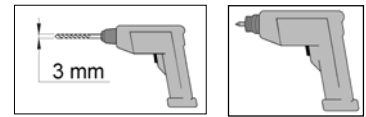

23

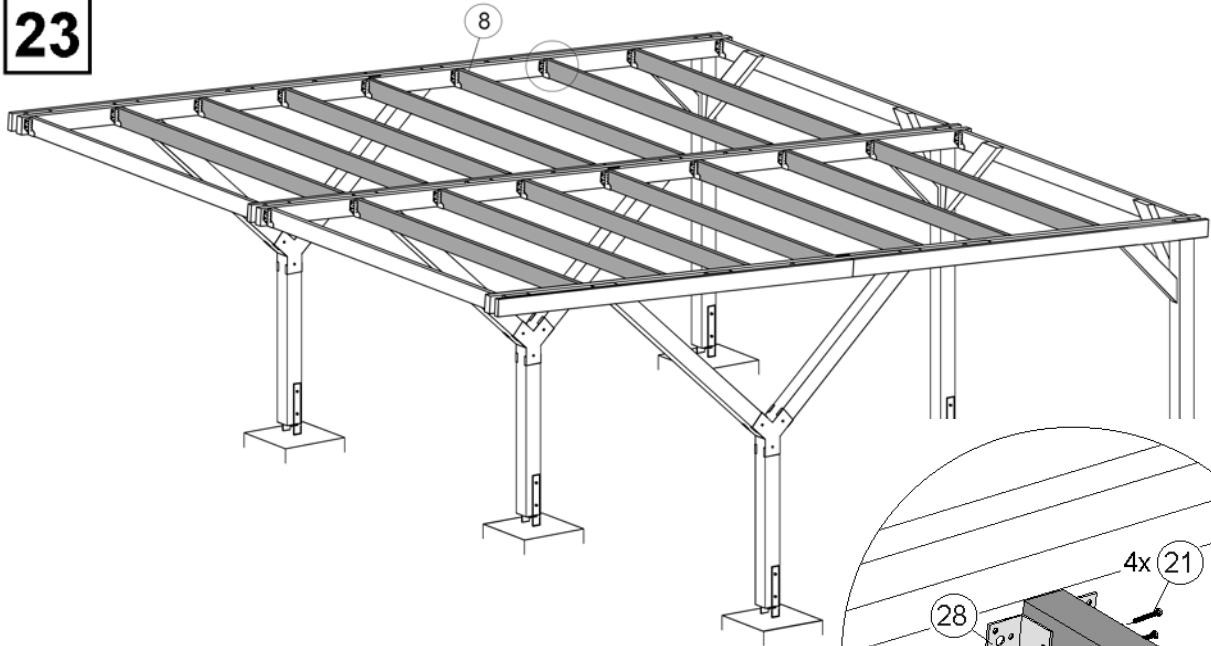

de	Diagonalstrebe
en	Diagonal strut
fr	Echarpe
it	Traversa diagonale

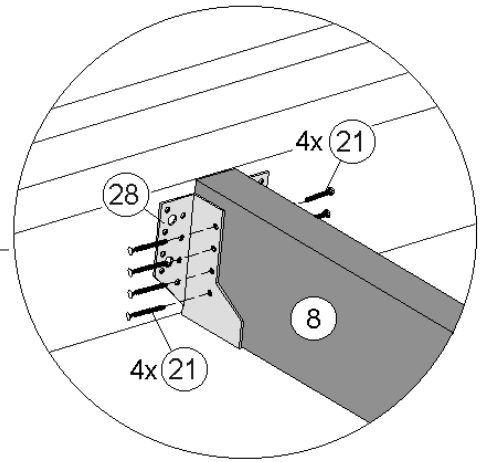
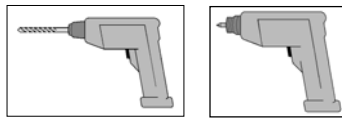

24

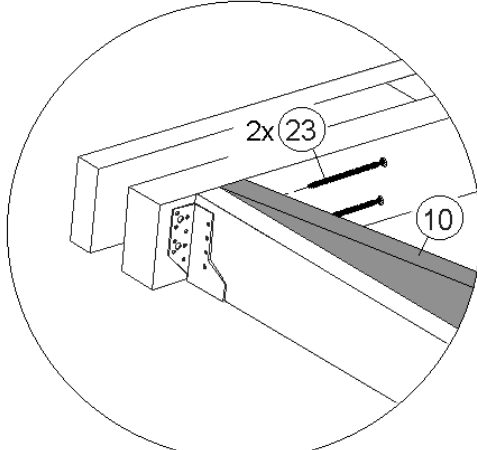
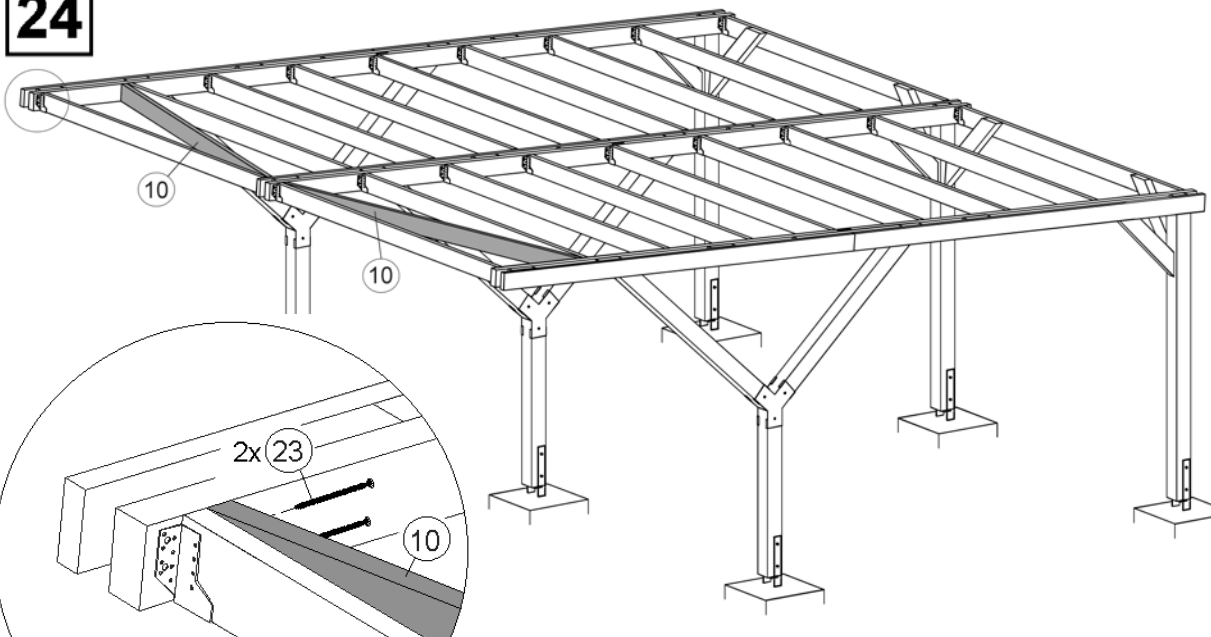

de	Blendbrett
en	Cover board
fr	Latte-cache
it	Visiera protettiva

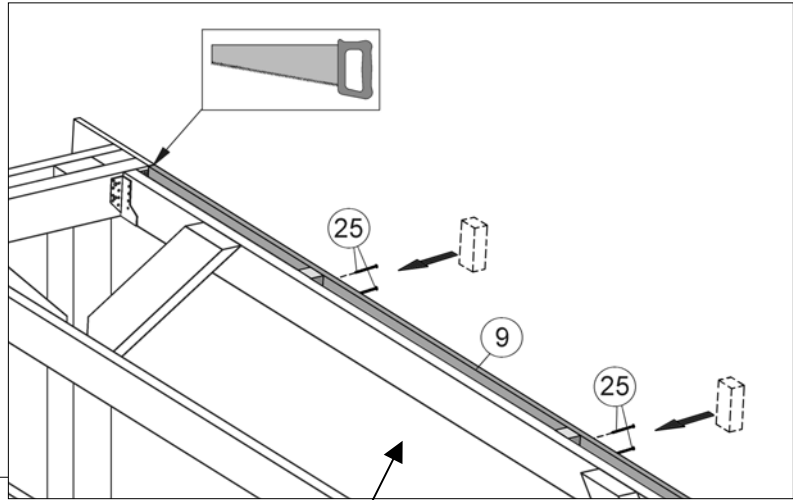
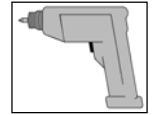
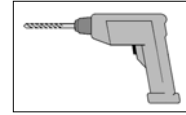

25

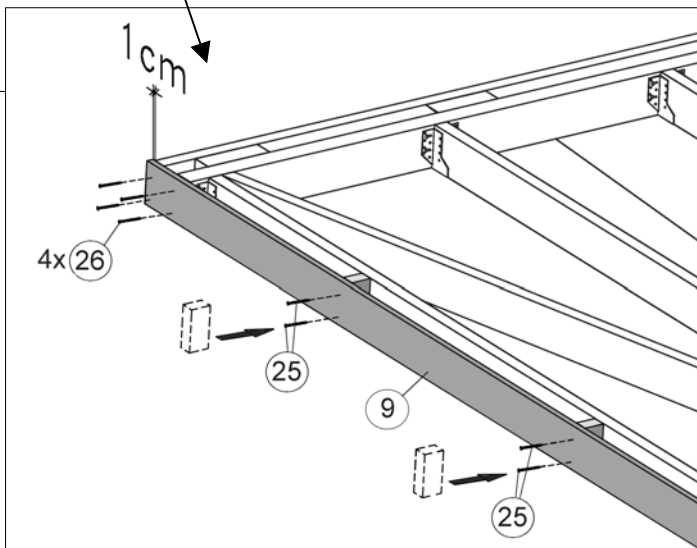
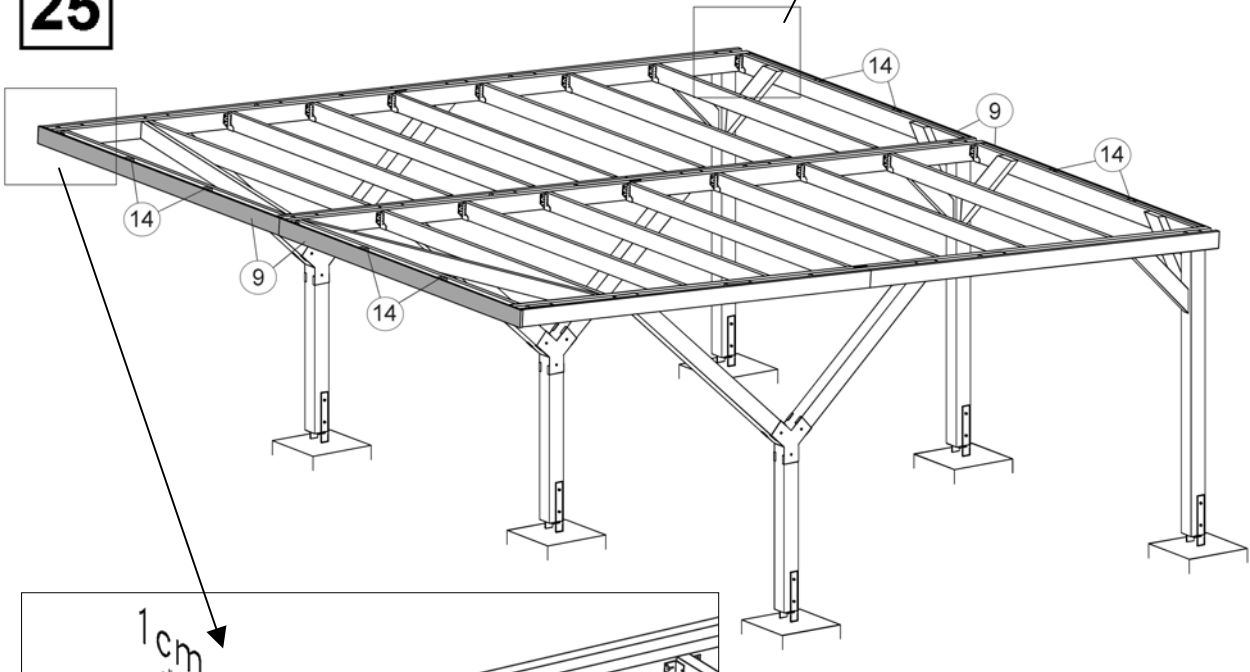

de	Dachplatte
en	Roof plate
fr	plaque de couverture
it	piastra del tetto

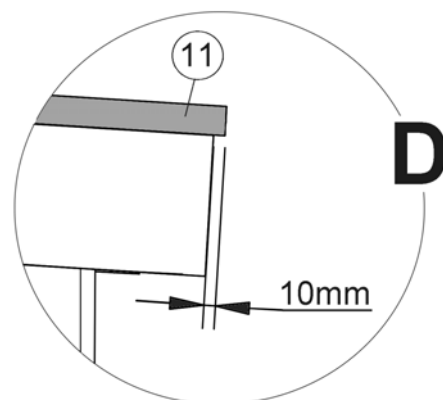
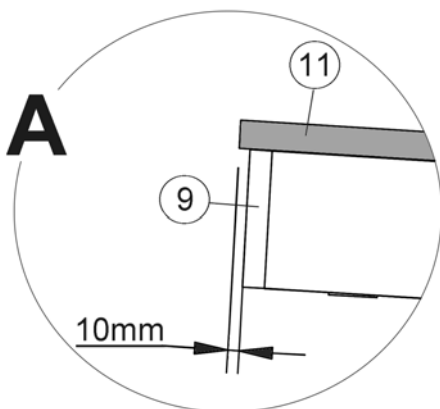
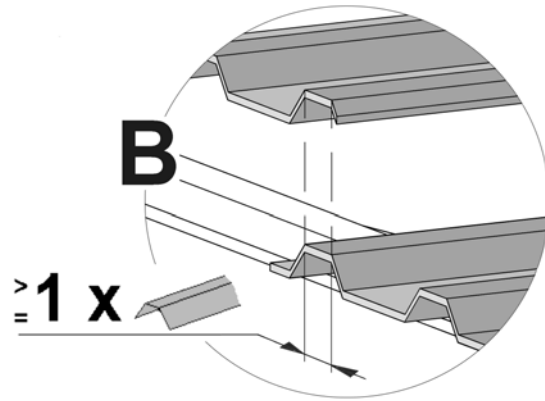
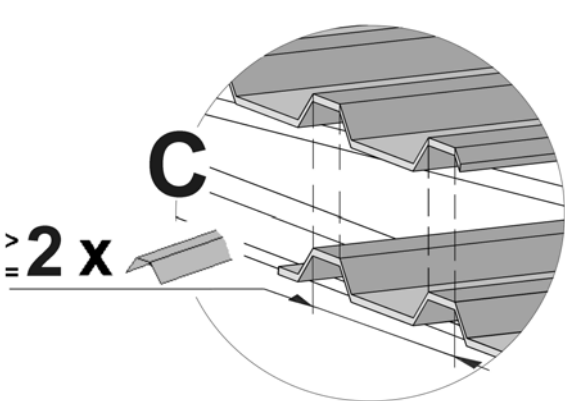
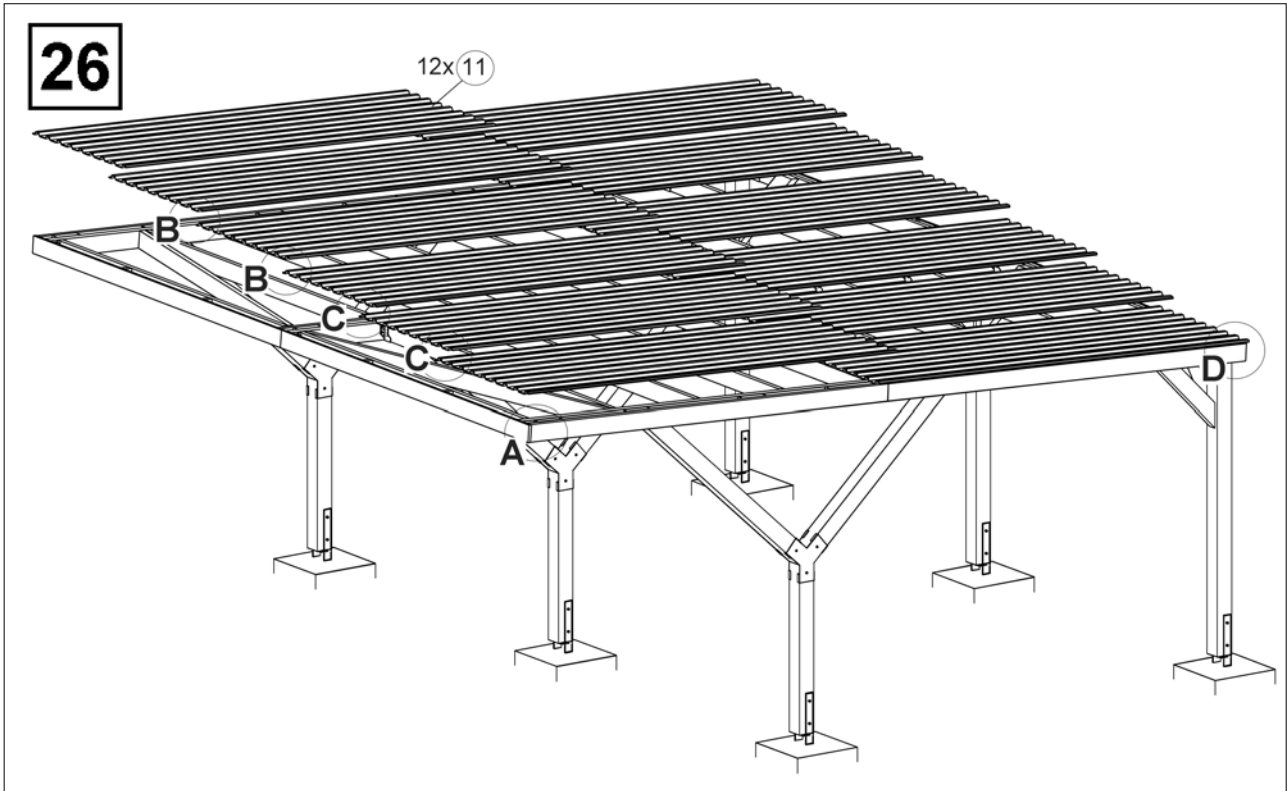
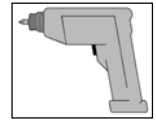
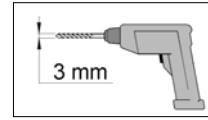
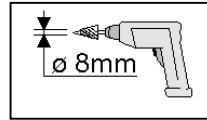

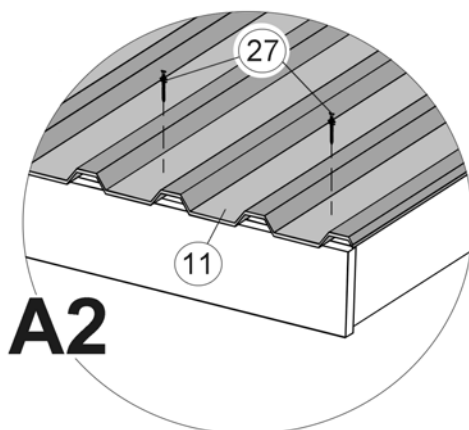
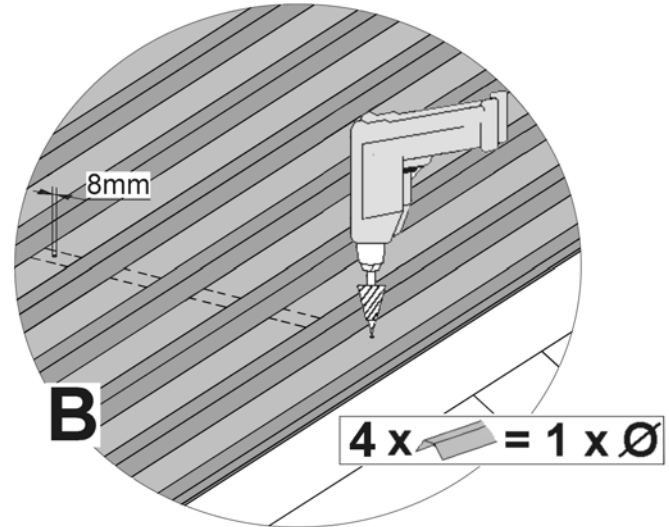
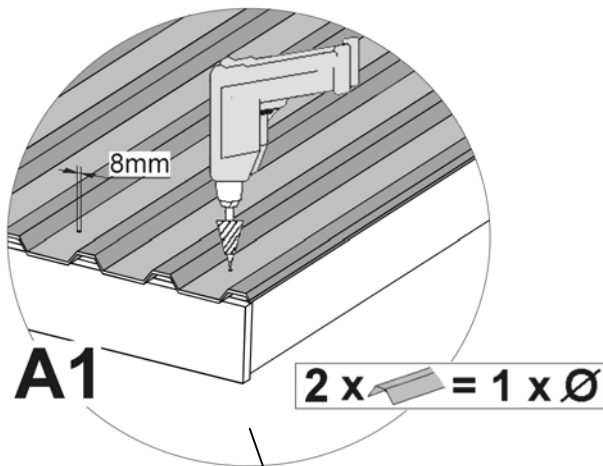
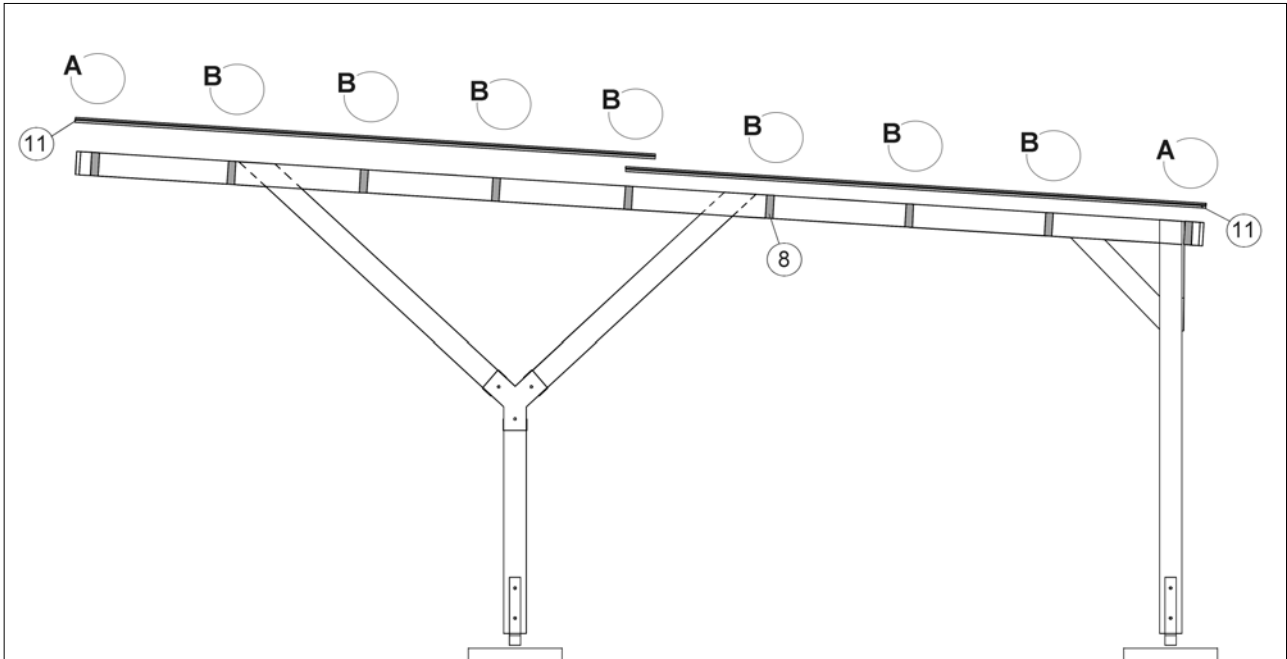
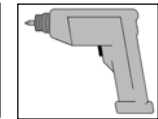
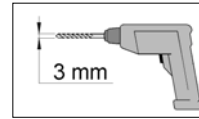
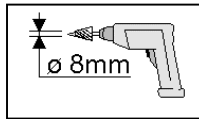

weka Holzbau GmbH, Johannesstr. 16
 D-17034 Neubrandenburg
 Tel.: 0395 42908-0
 Fax: 0395 42908-83
 EMail: Info@weka-Holzbau.com

MA Art.-Nr.: 800.0286.08.74