

92052 92053

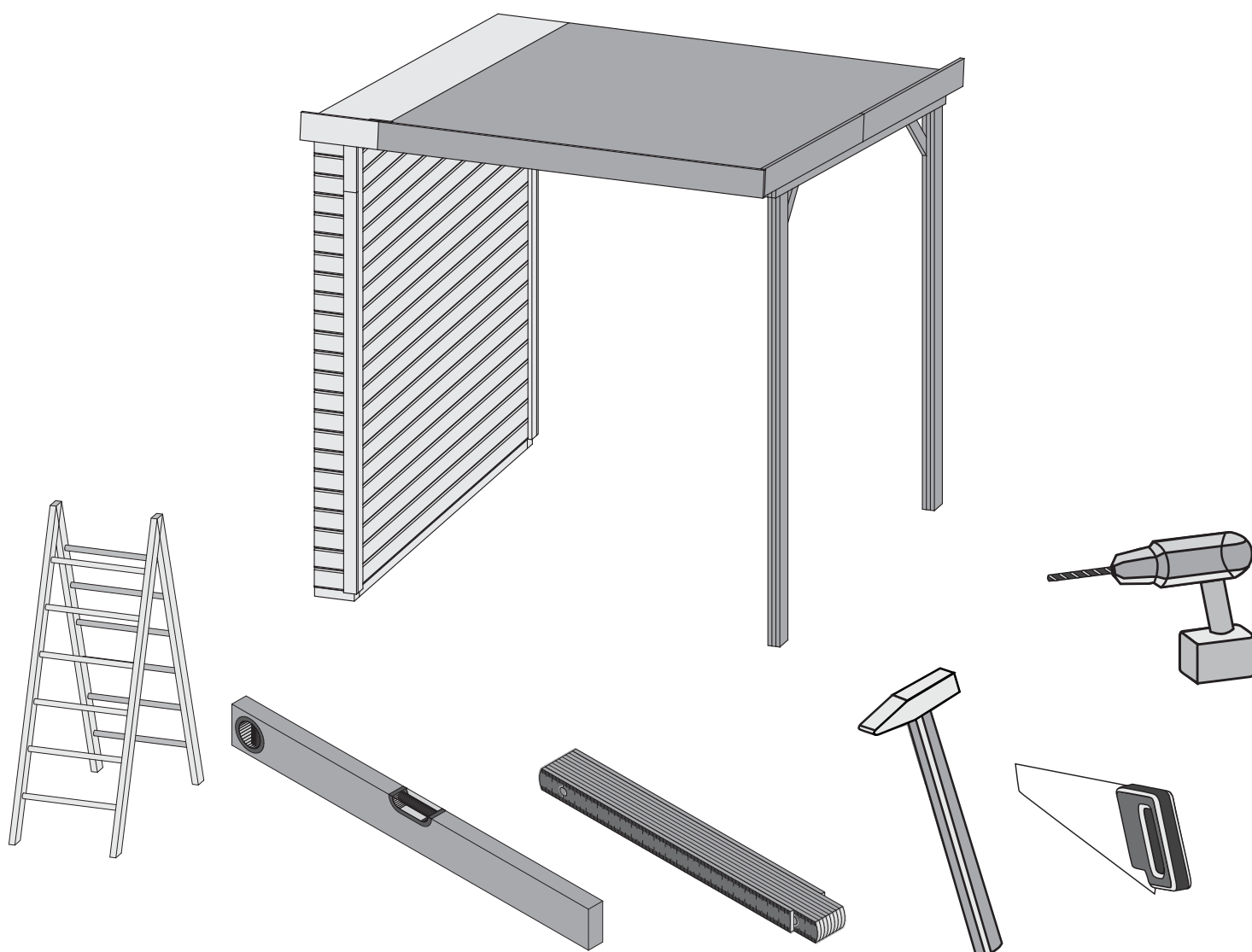

 **Aufbauanleitung**

 **notice de montage**

 **Building Instructions**

 **montagehandleiding**

 **Instrucciones de construcción**

 **Istruzioni per il montaggio**

 **Montážní návod**

 **Service-Hotline: +49 421 38693 33**



Vergleichen Sie zuerst die Materialliste mit Ihrem Paketinhalt! Bitte haben Sie Verständnis, dass Beanstandungen nur im nicht aufgebauten Zustand bearbeitet werden können!



En primer lugar, compare la lista de material con el contenido del paquete. Rogamos entienda que las reclamaciones sólo pueden ser tramitadas antes de montar el objeto!



Nejprve přezkontrolujte obsah balení podle materiálového listu! Mějte pochopení pro to, že případnou reklamaci se můžeme zabývat pouze tehdy, když díly nebudou smontované! Za pomoci tohoto seznamu můžete jednotlivé díly přiřadit k montážnímu návodu.



Vergelijk eerst de lijst van materialen met de inhoud van uw pakket! Reclamaties kunnen alleen in behandeling worden genomen zolang de onderdelen nog niet zijn gemonteerd!



First compare the list of materials with your package contents! Please understand that complaints can be processed in the non-built status only!



Commencez par comparer la liste du matériel avec le contenu de votre paquet! Sachez que nous traitons uniquement les réclamations concernant le matériel à l'état non monté!



Confrontate questa distinta materiali prima con il contenuto del pacchetto! Vi preghiamo di comprendere che eventuali reclami possono essere accolti solo prima del montaggio!

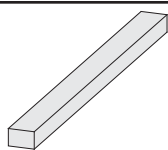
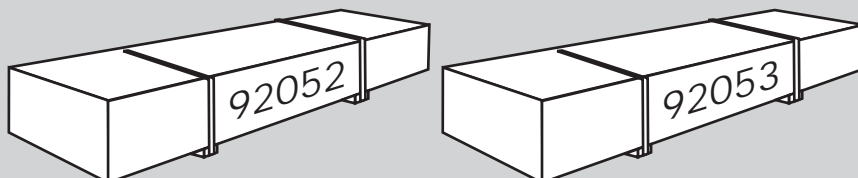

2 x B2	100 x 36 x 18mm	ID 59421
2 x B7	1800 x 45 x 18mm	ID 19546
1 x B21	1740 x 120 x 18mm	ID 27715

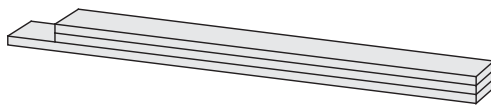

2 x P1	2110 x 95 x 54mm	ID 68375
--------	------------------	----------

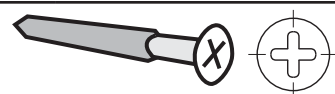

100 x	4 x 25mm	ID 5841
100 x	4 x 30mm	ID 3686
100 x	4 x 50mm	ID 3688
20 x	4 x 70mm	ID 3689

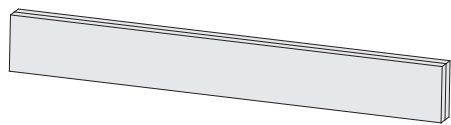

5 x E1	1826 x 95 x 36mm	ID 68388
1 x E2	2040 x 95 x 36mm	ID 67312

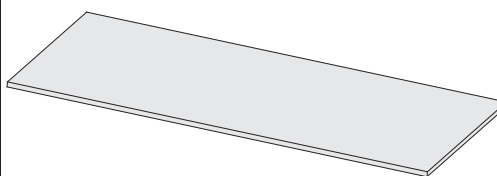

2 x D1	610 x 870 x 16mm	ID 58037
2 x D2	1740 x 870 x 16mm	ID 45414

10 x

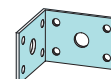

ID 21292



2 x K1	400 x 58 x 18mm	ID 67300
--------	-----------------	----------



Hinweis

Die Pfosten dieses Produkts sollten fest mit dem Untergrund verbunden werden. Dazu empfehlen wir H-Pfostenanker. Diese sollten erst nach dem Aufbau dieses Produkts endgültig mit Beton versehen werden. **Die H-Pfostenanker und das zugehörige Befestigungsmaterial sind nicht im Lieferumfang dieses Produkts enthalten.**

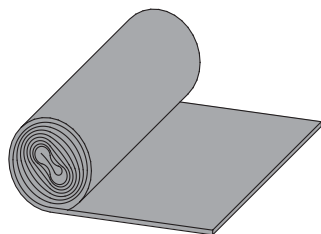

Nicht im Lieferumfang enthalten



Niet bijgeleverd



Not included



Non comprises dans la livraison



No forman parte del suministro



Non incluso



V ceně není zahrnuto

01 1x

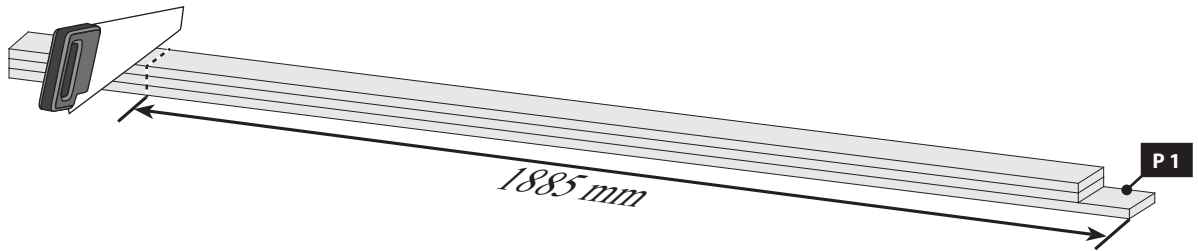

02 2x

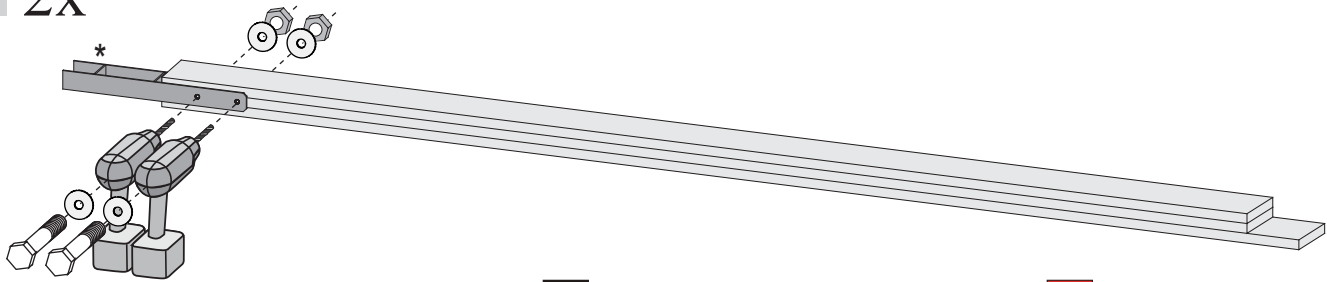

 * Nicht im Lieferumfang enthalten

 * No forman parte del suministro

 * Niet bijgeleverd

 * Non incluso

 * Not included

 * V ceně není zahrnuto

 * Non comprises dans la livraison

03

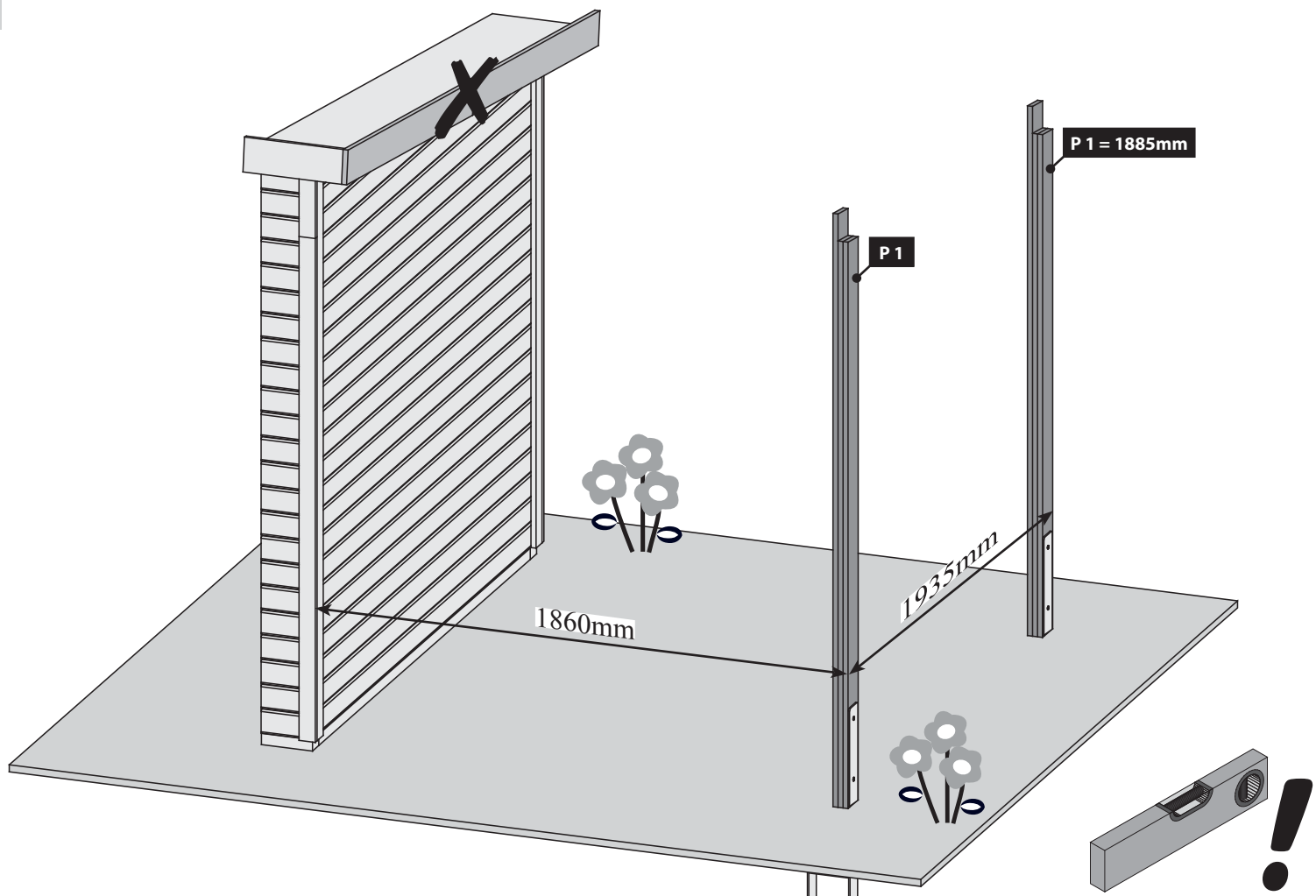

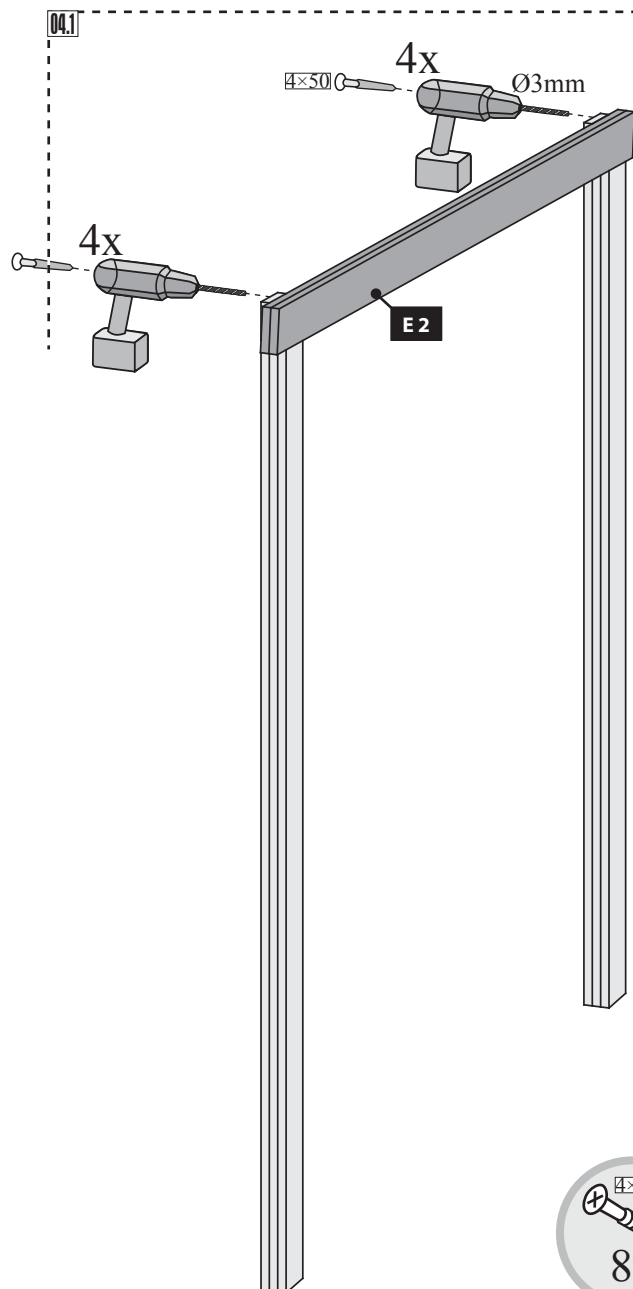
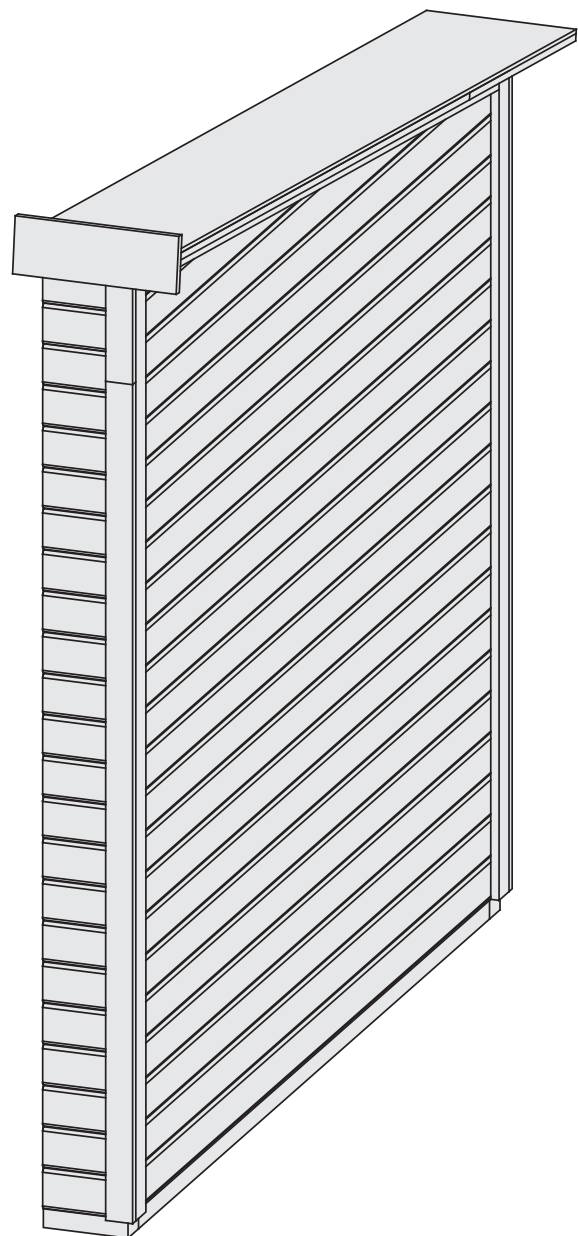

04.1

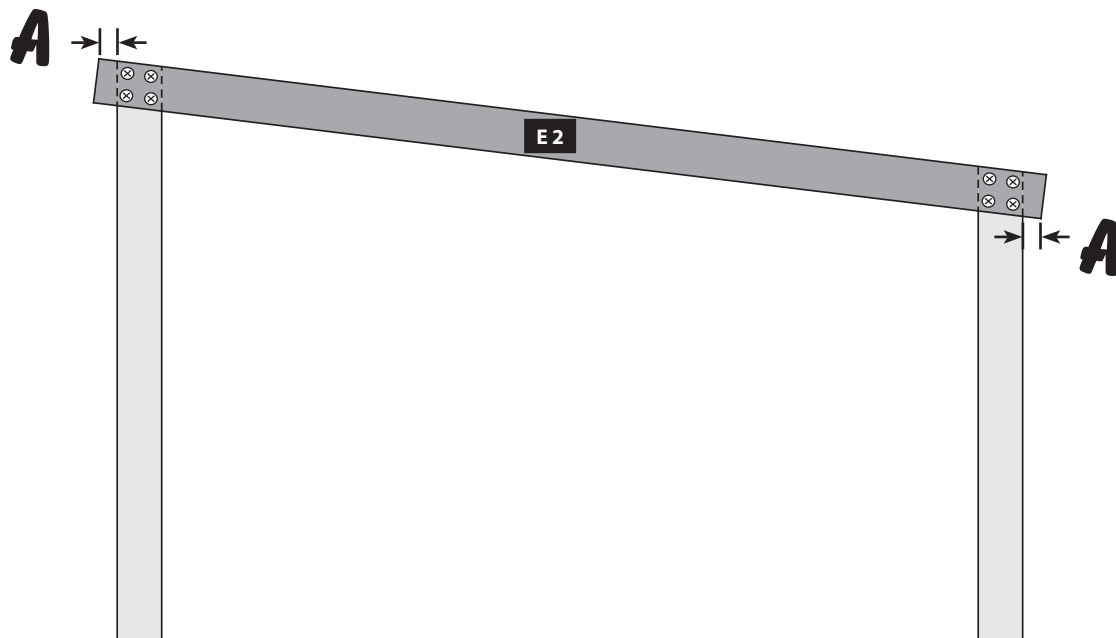
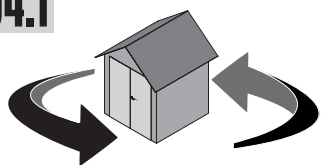

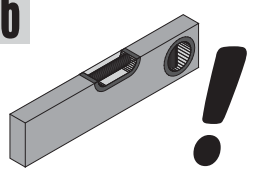
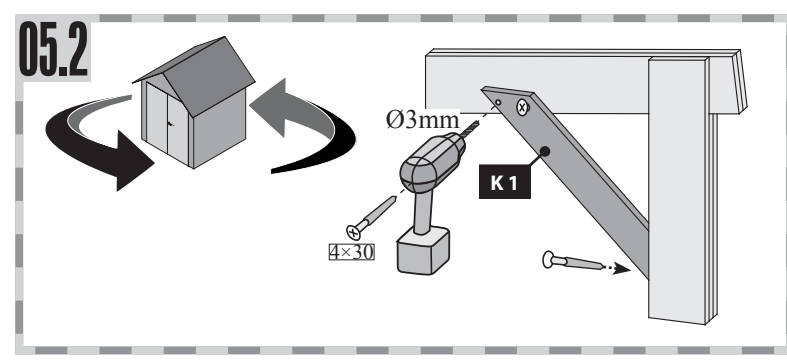
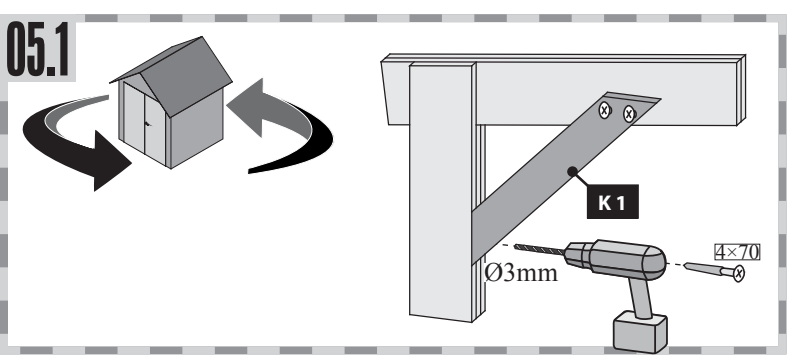
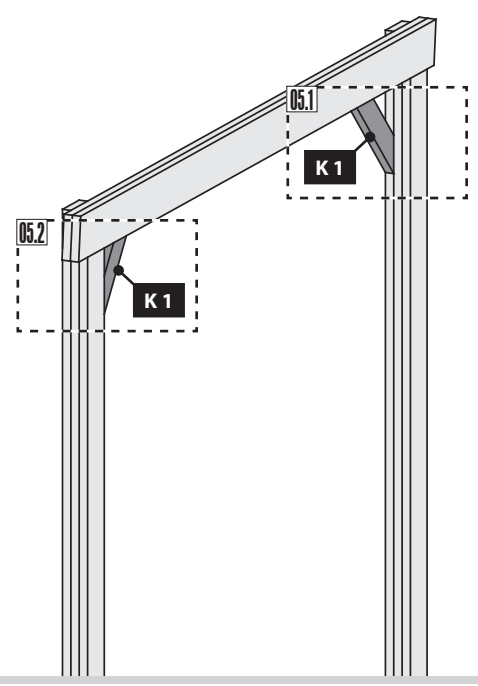
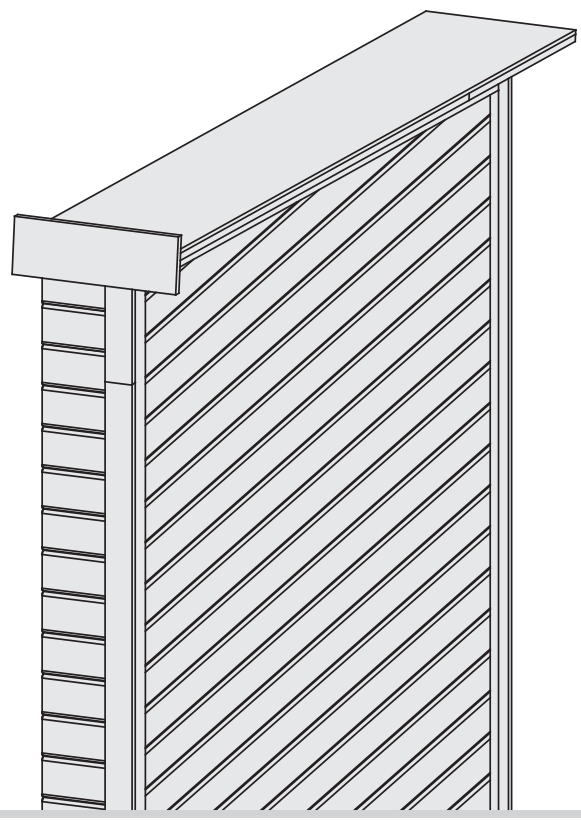
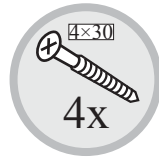

Bündig!
Affleurement!
Gelijk!
Aras!
Flush!
Combacia!
Flush!

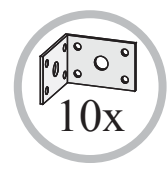
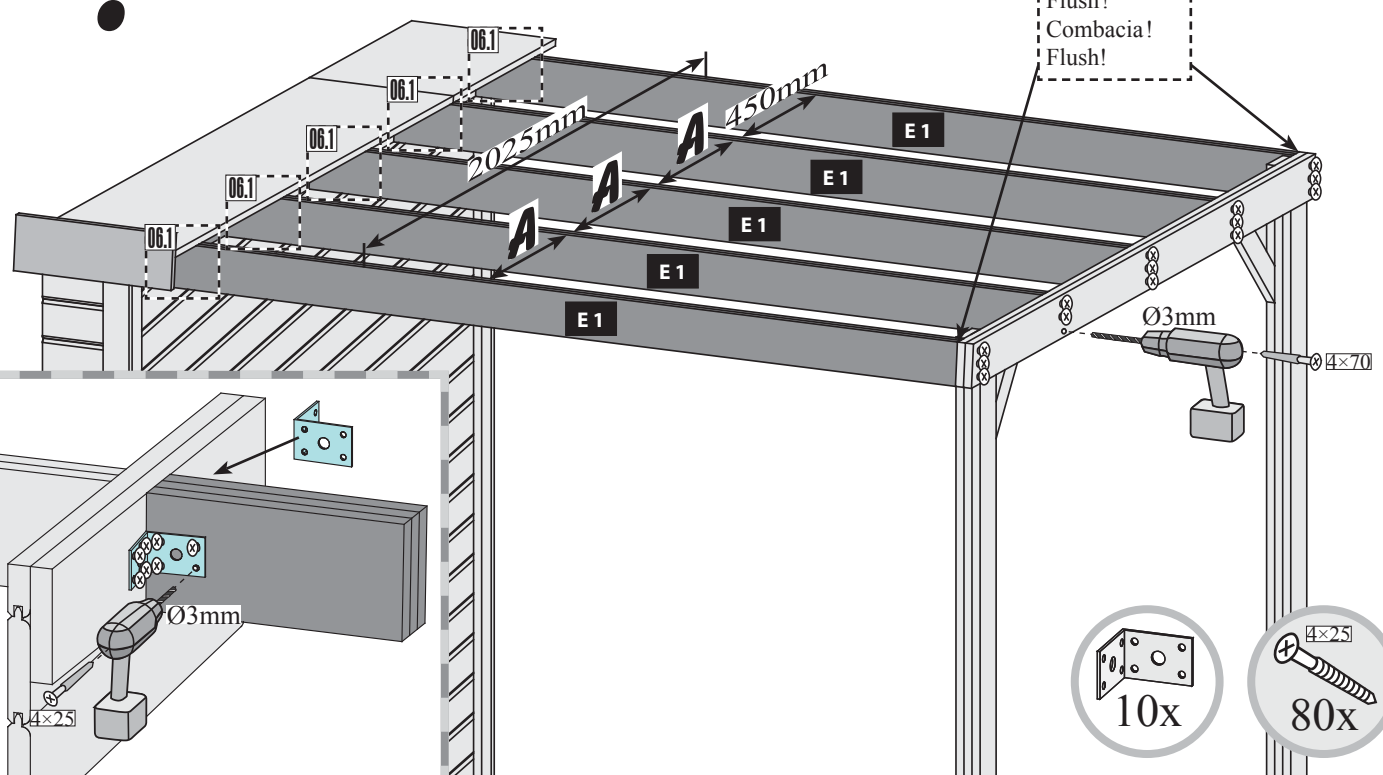

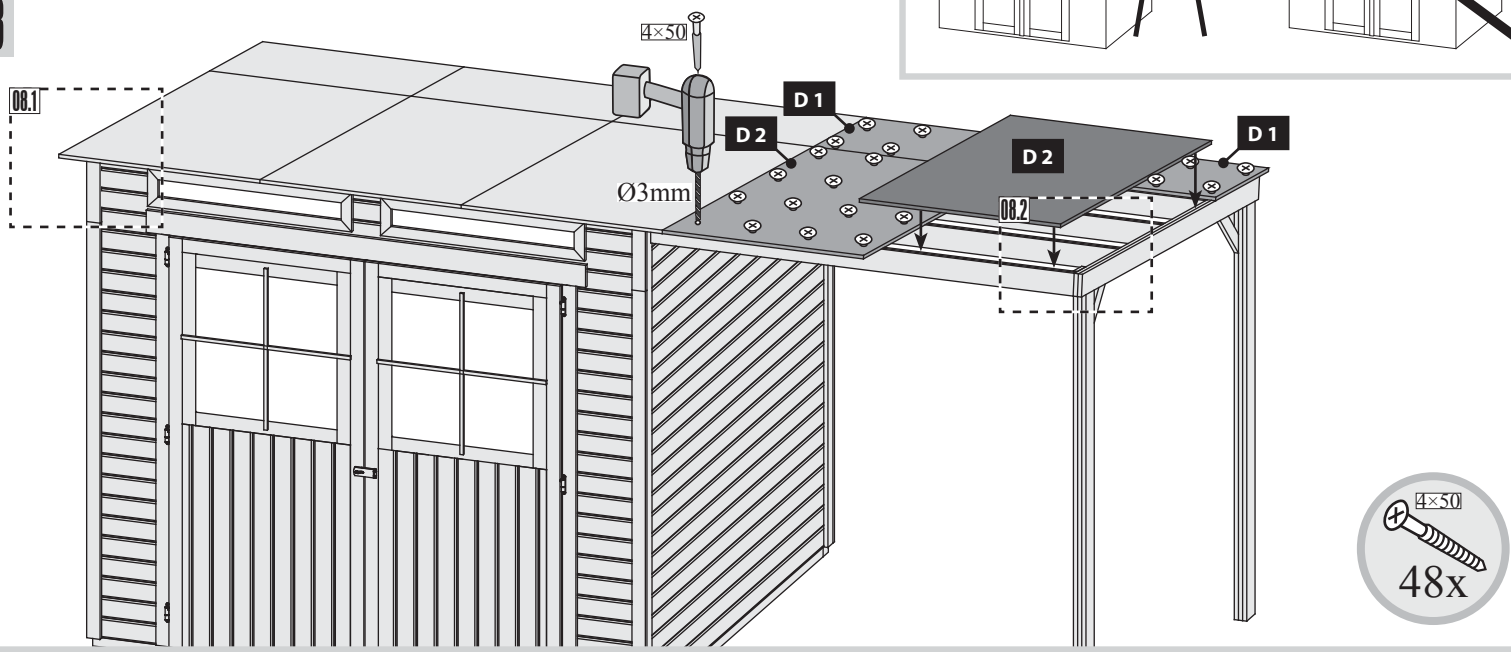
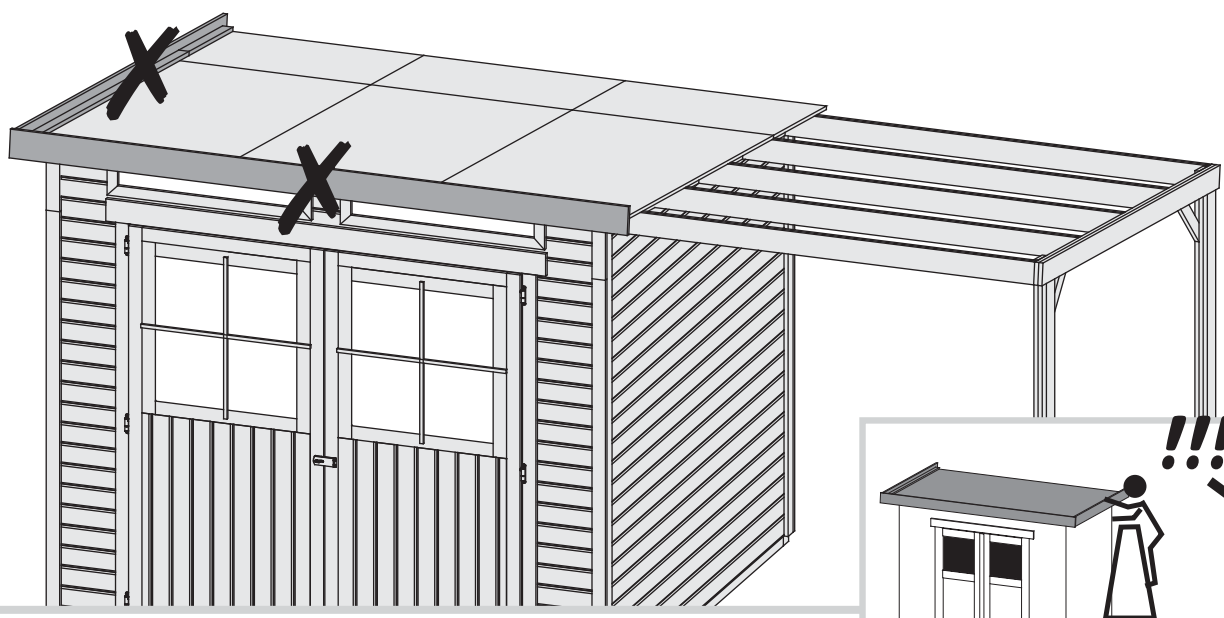

91906 91907 88486 21.06.2018

- Aufbauanleitung
- notice de montage
- Building Instructions
- montagehandleiding
- Instrucciones de construcción
- Istruzioni per il montaggio
- Montážní návod
- Service-Hotline: +49 421 38693 33

08.1

ca 122mm
ca 130mm

08.2

ca 130mm

Bündig!
Affleurement!
Gelijk!
Aras!
Flush!
Combacia!
Flush!

91904 91905 88484 17.06.2018

- Aufbauanleitung
- notice de montage
- Building Instructions
- montagehandleiding
- Instrucciones de construcción
- Istruzioni per il montaggio
- Montážní návod
- Service-Hotline: +49 421 38693 33

08.1

ca 72mm
ca 130mm





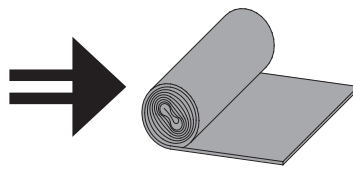

08.2

ca 130mm

Bündig!
Affleurement!
Gelijk!
Aras!
Flush!
Combacia!
Flush!



ID 68589

-  Für die dauerhafte Eindeckung empfehlen wir die selbstklebende Bitumendachbahn aus unserem Sortiment
-  For permanent covering, we recommend self-adhesive bitumen roofing sheet from our range
-  Pour revêtement permanent, nous vous recommandons de bitume auto-adhésif tôle de toiture de notre gamme
-  Voor permanente bedekking, raden wij zelfklevende bitumen dakbaan uit ons assortiment
-  Para cobertura permanente, recomendamos betún autoadhesivas Perfil de cubierta de nuestra gama
-  Per copertura permanente, si consiglia di bitume autoadesive Lastra per coperture della nostra gamma
-  Pro trvalé krytinou, doporučujeme samolepící asfaltové střešní krytiny z našeho sortimentu

10 1x

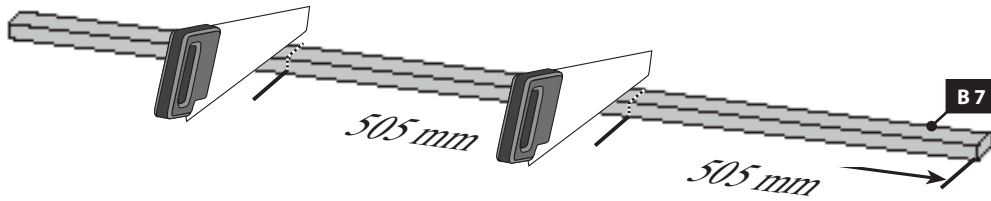

11

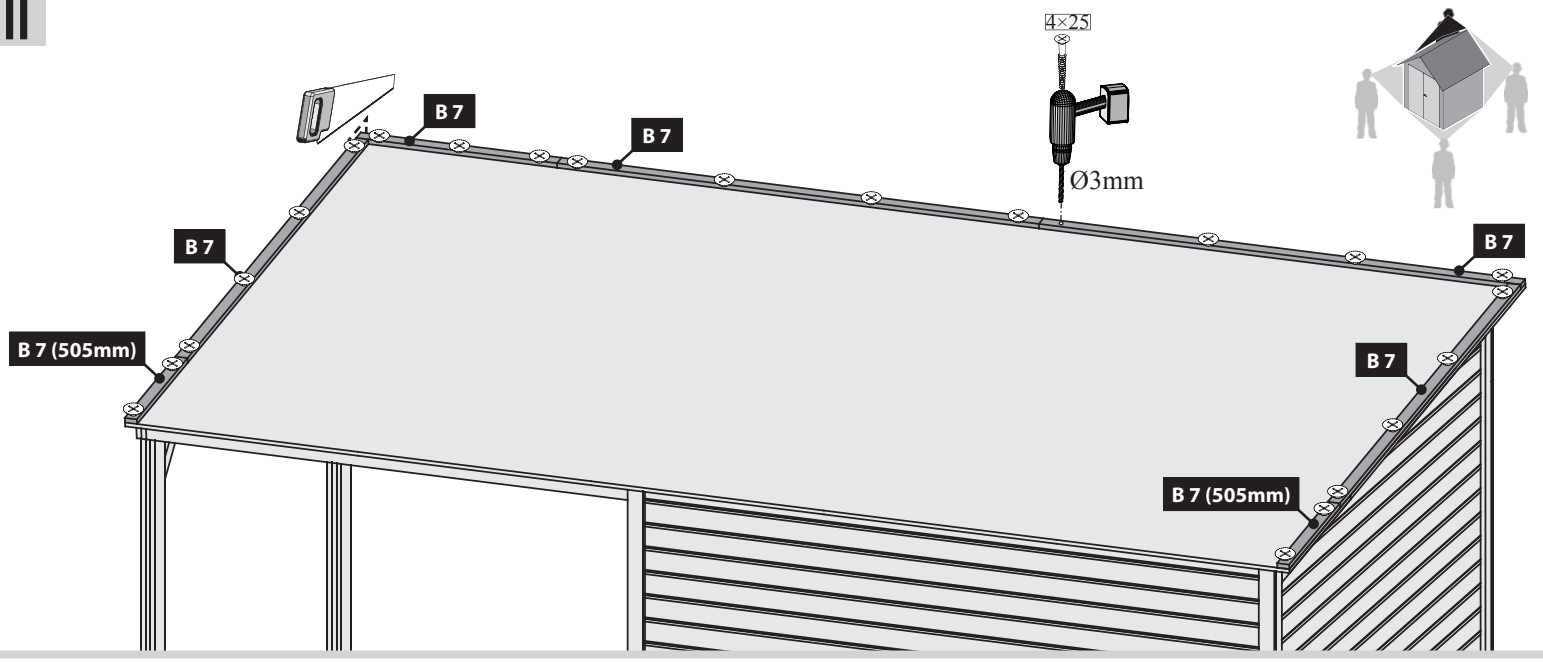

12

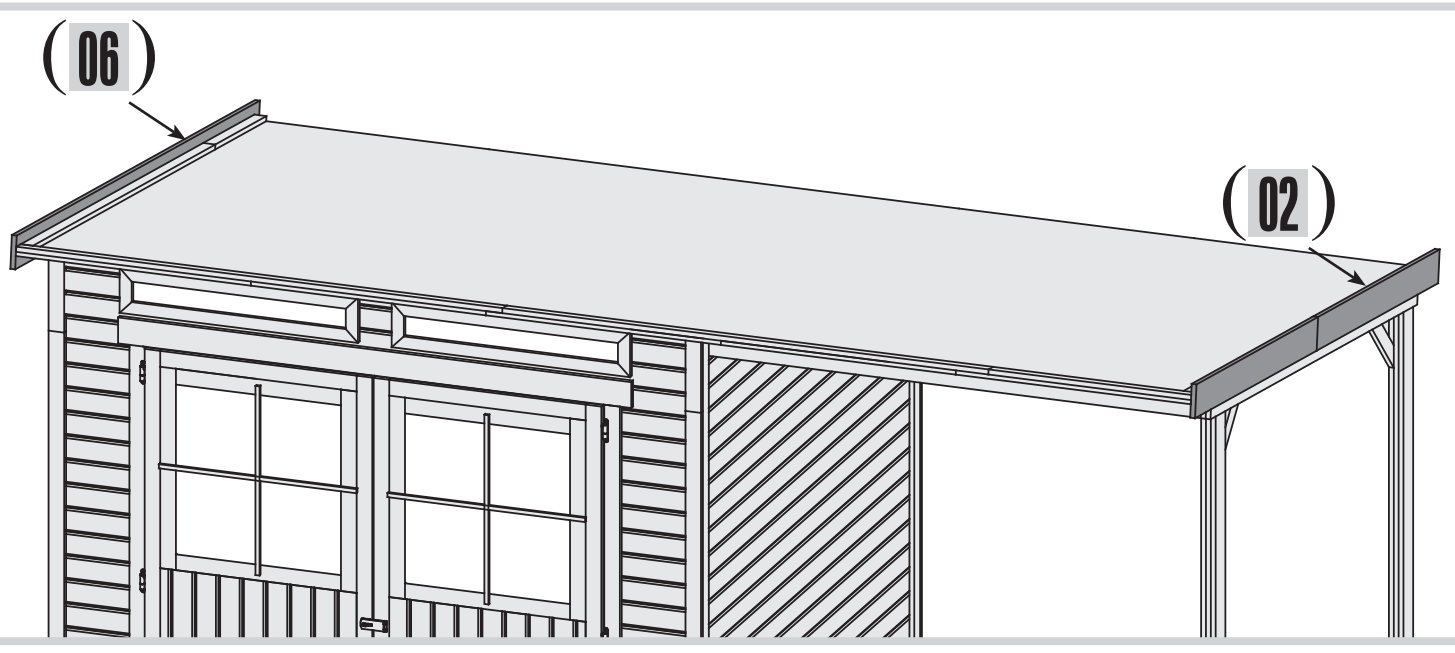

13

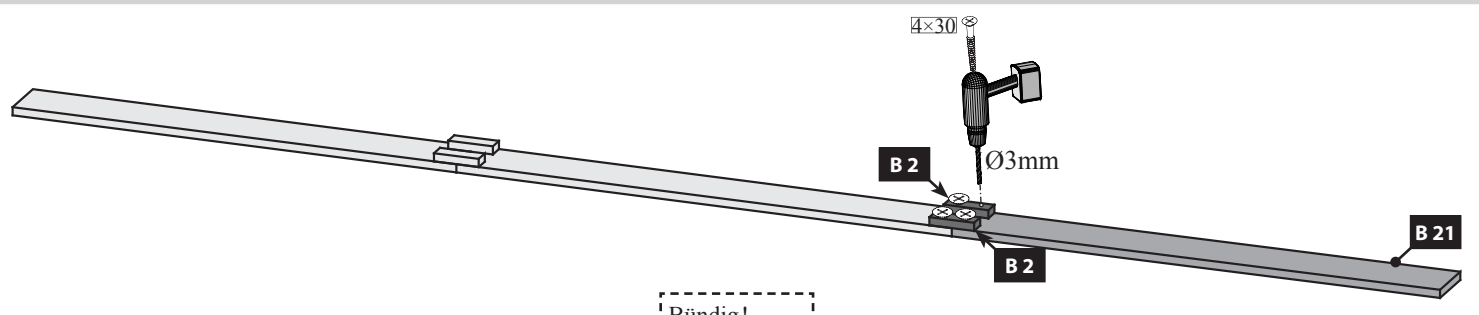

Bündig!
Affleurement!
Gelijk!
Aras!
Flush!
Combacia!
Flush!

14

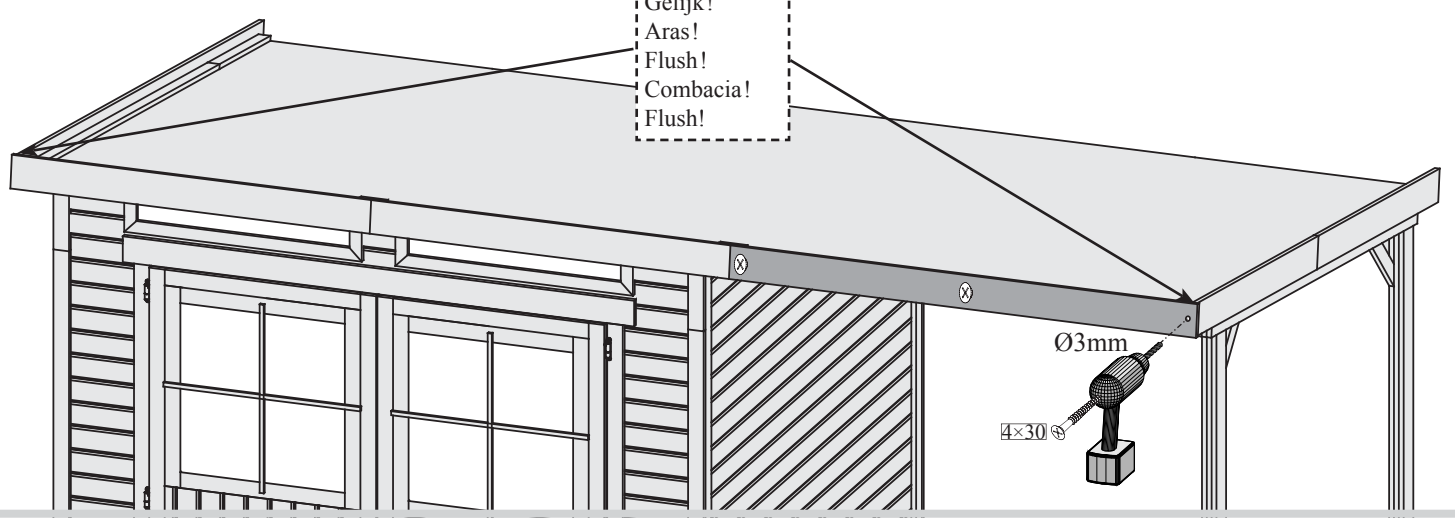

11

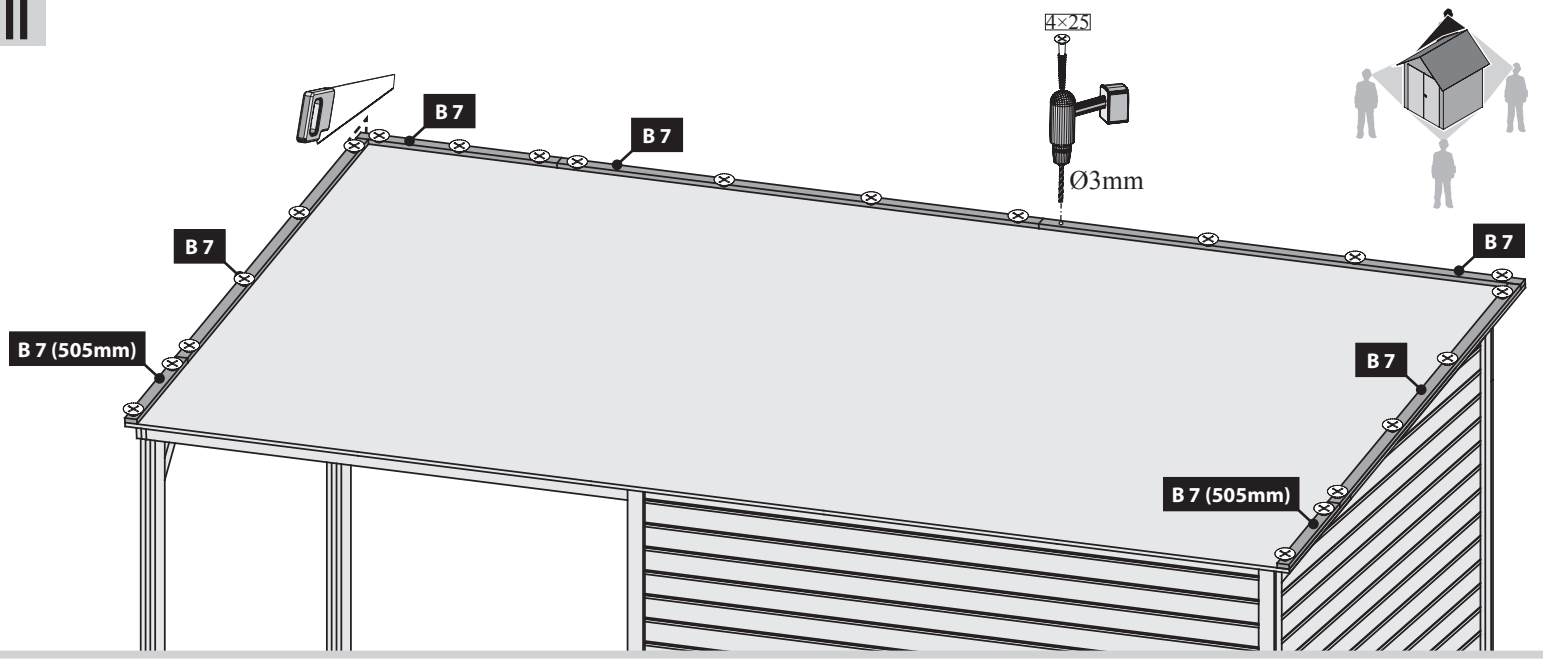

12

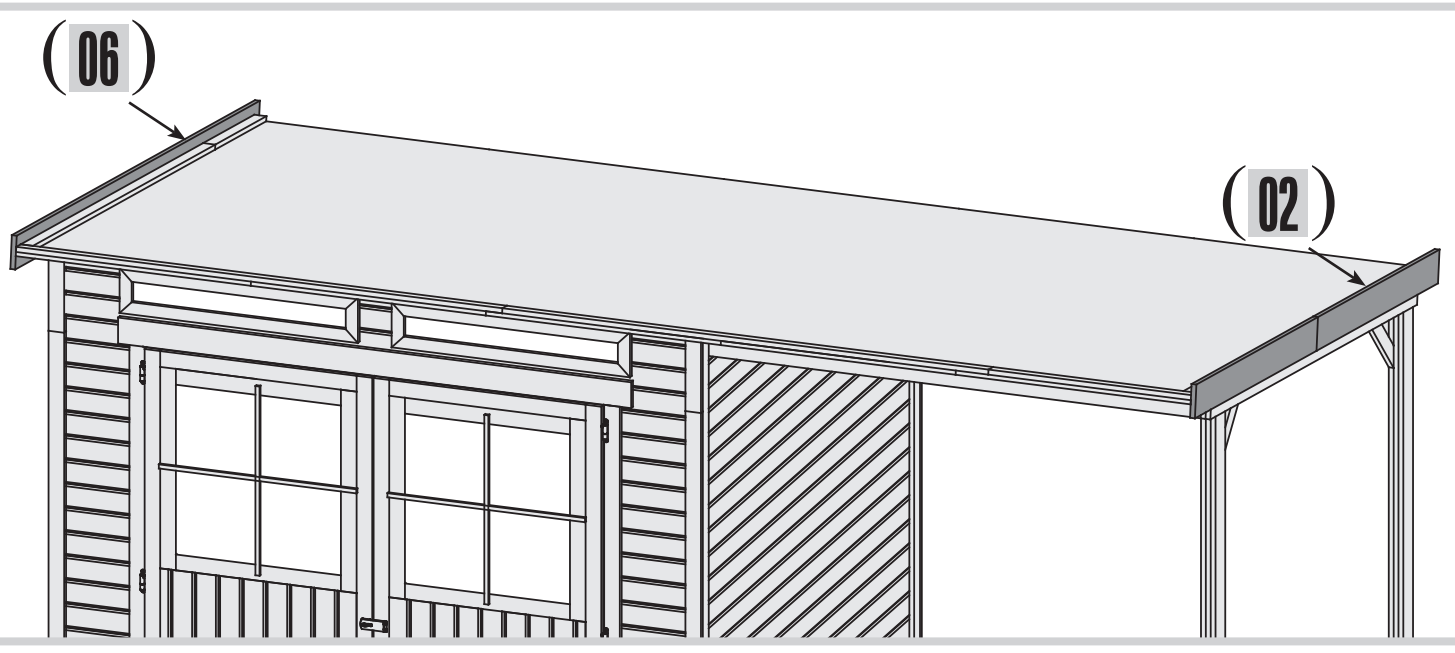

13

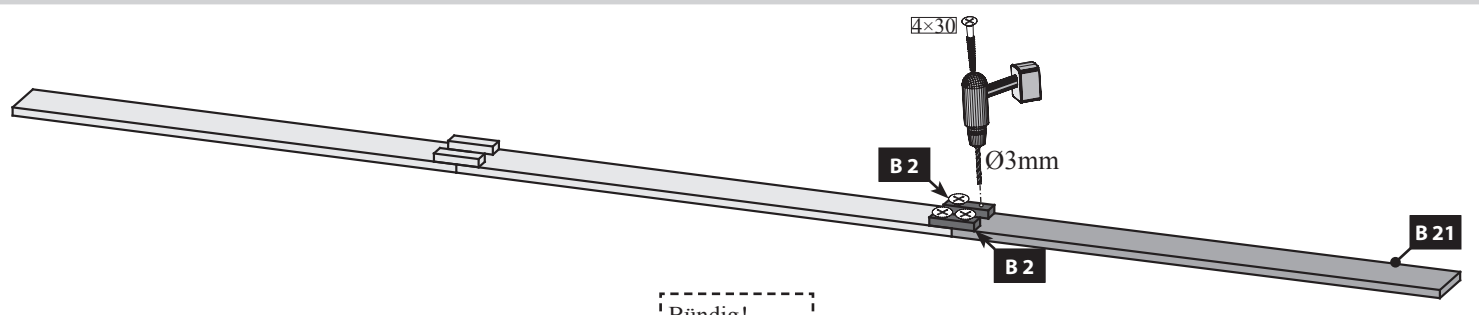

Bündig!
 Affleurement!
 Gelijk!
 Aras!
 Flush!
 Combacia!
 Flush!

14

