

Montageanleitung

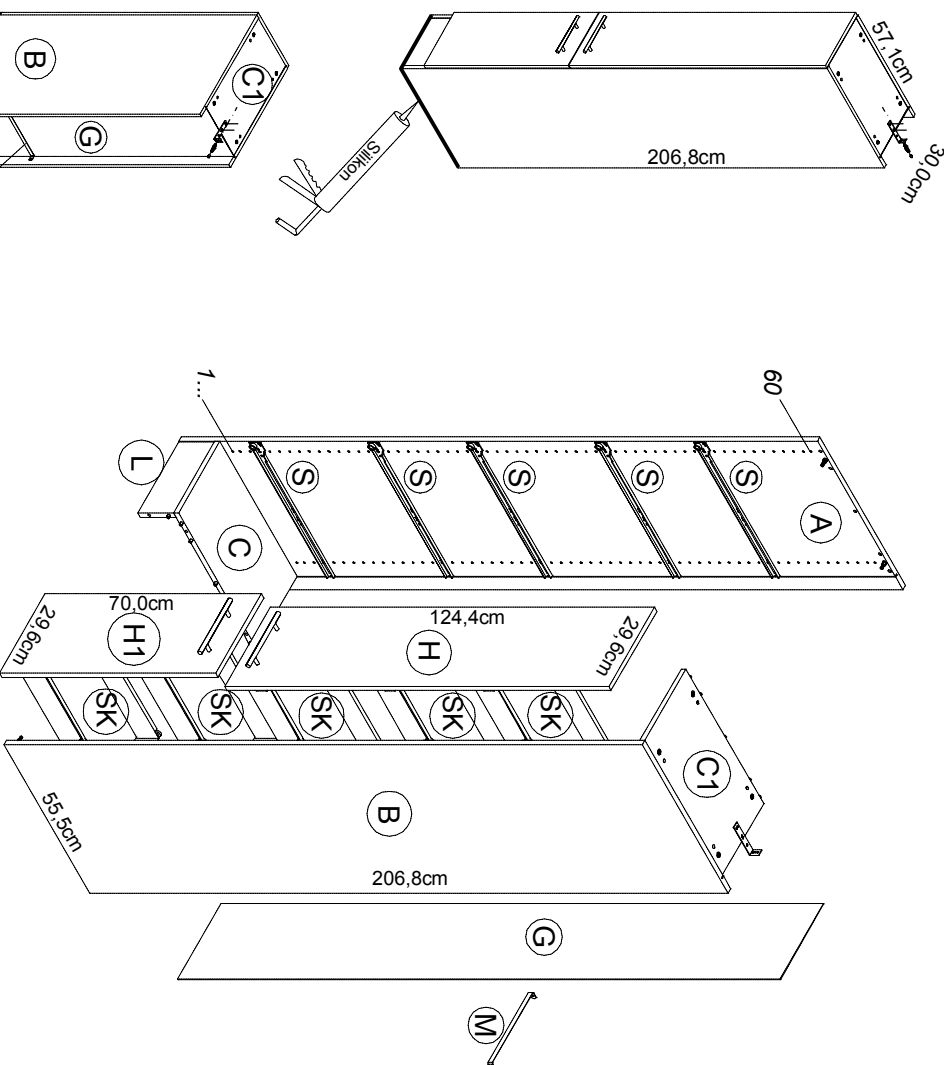

Service-Hotline
01805-678101
0,14€ pro Minute
+ +49 für Österreich
Auslandstarif pro Minute
service@jaka-bkl.de
voor Nederland en België
00800-40119350
benelux@jaka-bkl.de

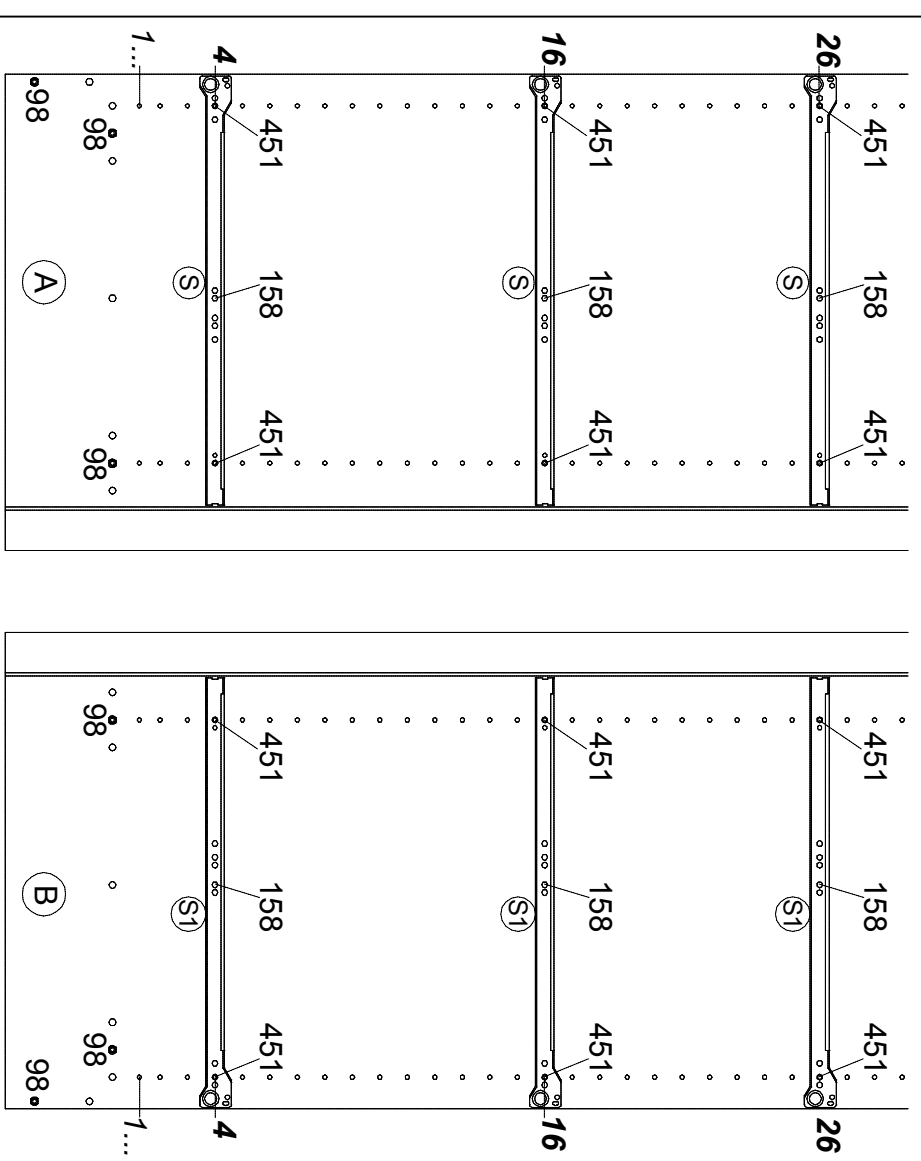
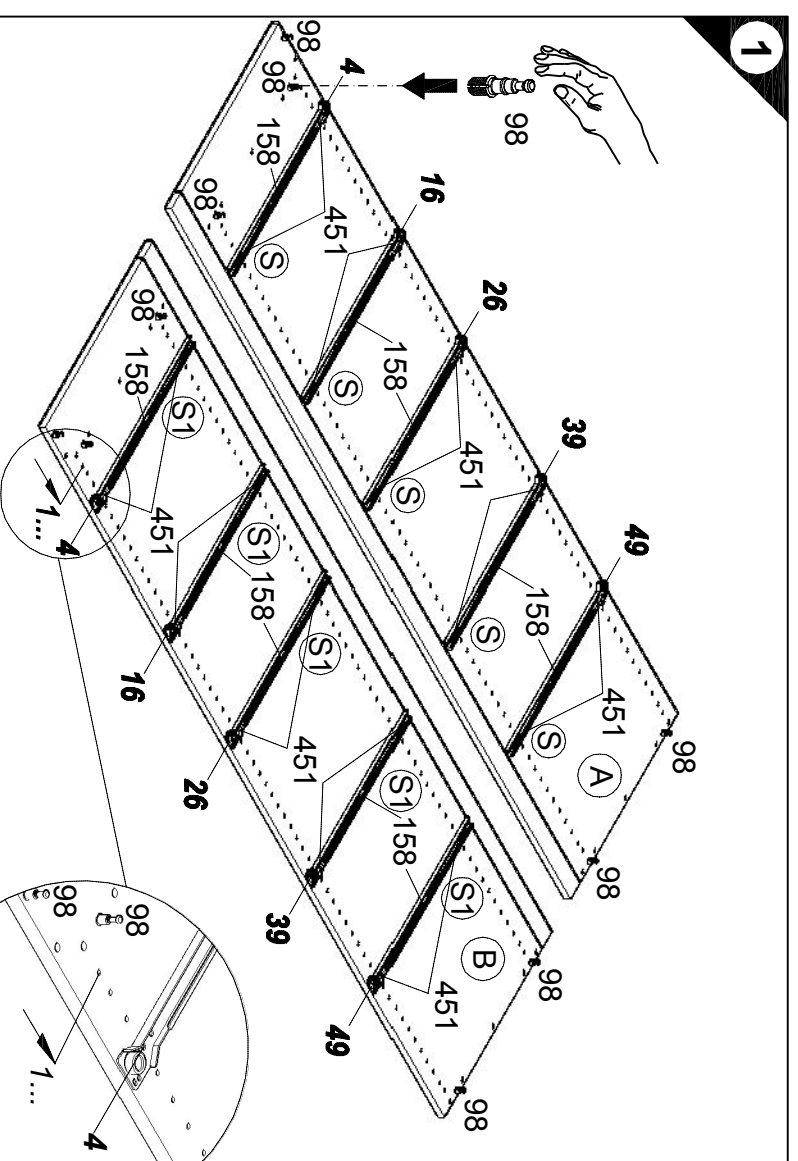
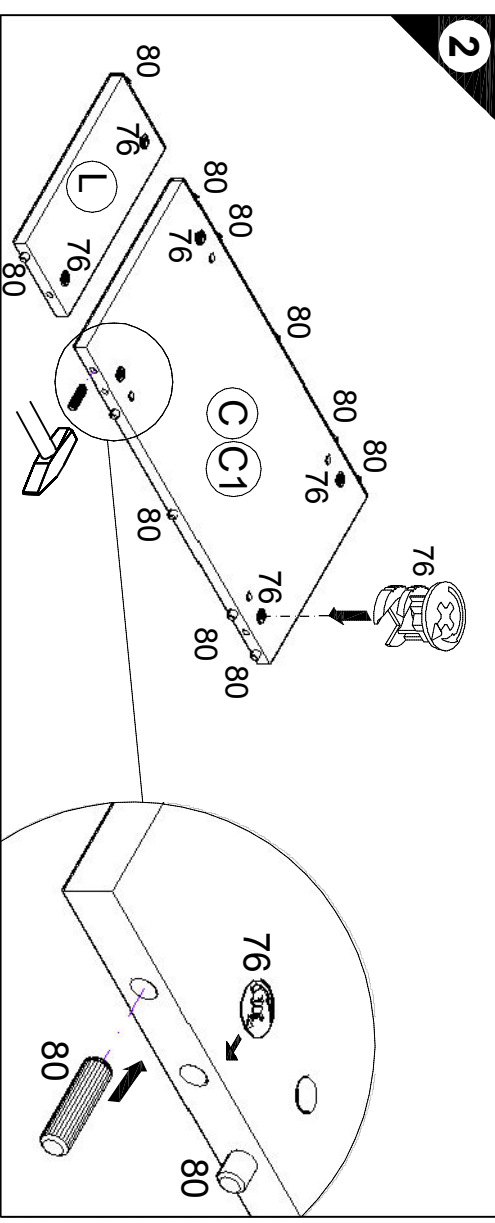

Ersatzteile/Spare parts/pièces de rechange/Reserveonderdelen/Piezas de recambio/Ricambi/Запасные части/Części zamienne/półkatrészek/Náhradní části/Nadomestni deli/Varaosat/reservdelar/náhradné diely/Utilizaji piese de schimb/Υedek parçalar

30cm HFZ306-7-9 (A) E961011 (B) E961012 (C) E954216 (C1) E954216 (G) E970023 (H) E940607 (H1) E940596 (L) E970976 (M) E948045 (S) E946003 (S1) E946004

30cm HFZ306-6 (A) E961011 (B) E961012 (C) E954216 (C1) E954216 (G) E970023 (H) E980607 (H1) E980596 (L) E970976 (M) E948045 (S) E946003 (S1) E946004

500626.1B 01/19 sl

1 → 2 → 3 ...

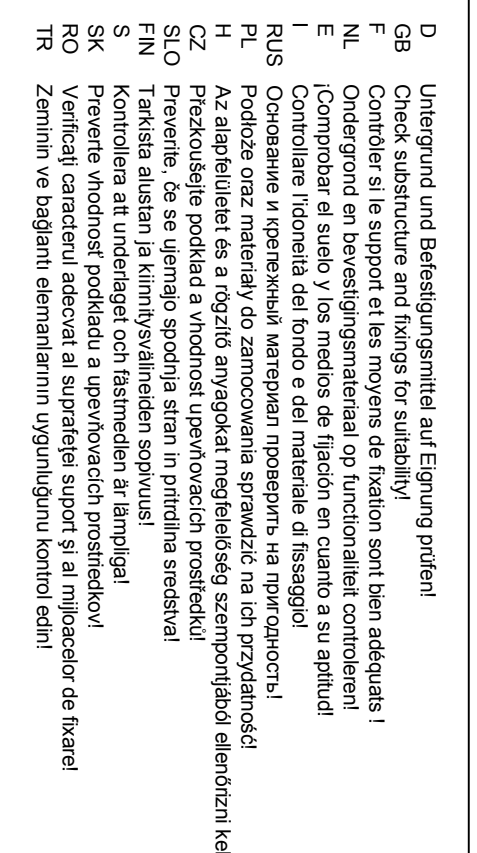
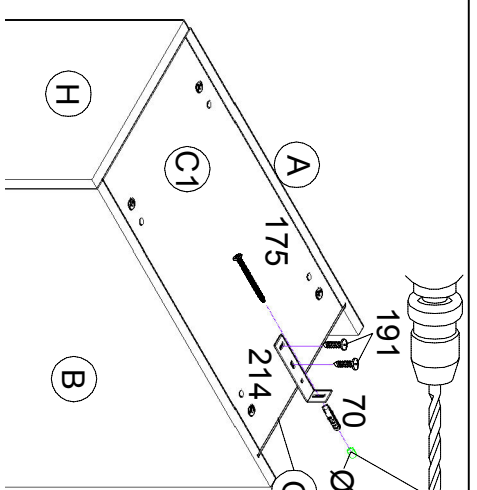
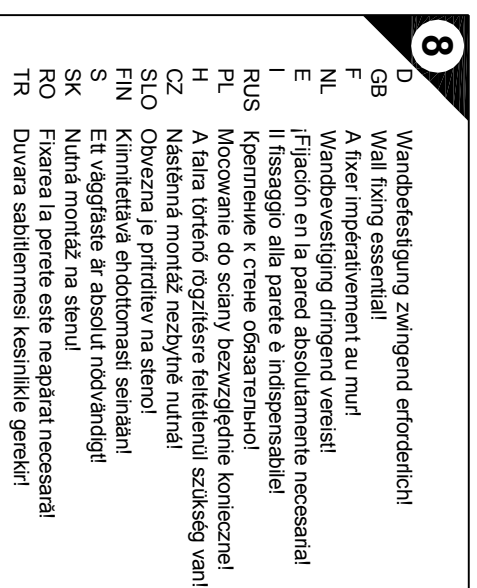
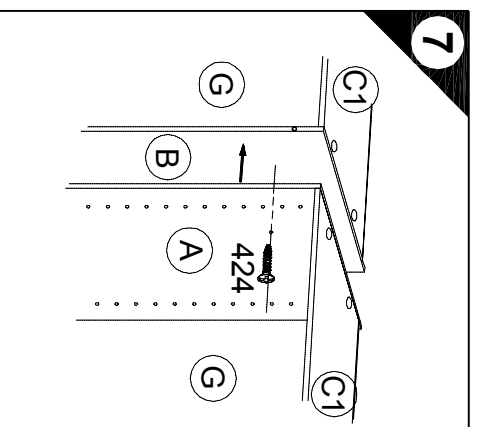
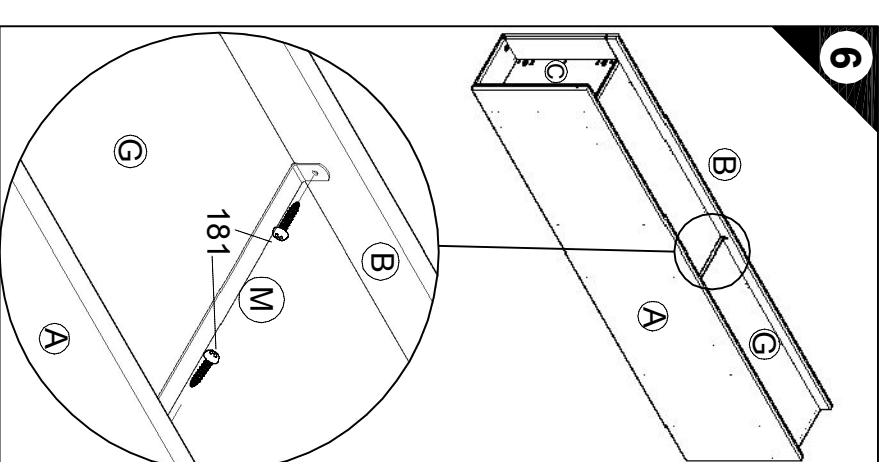
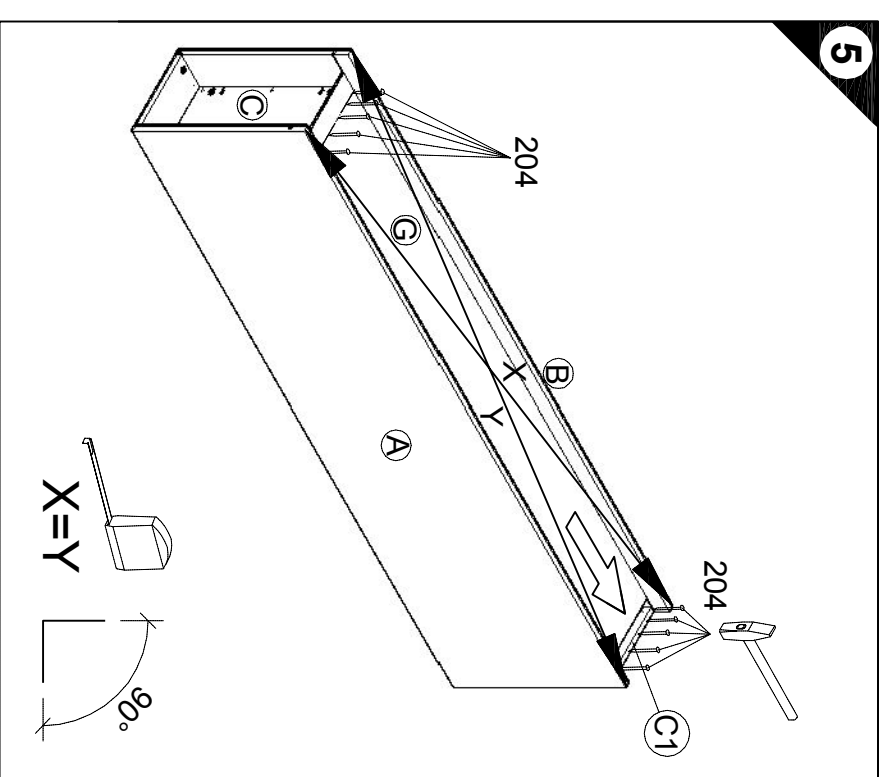
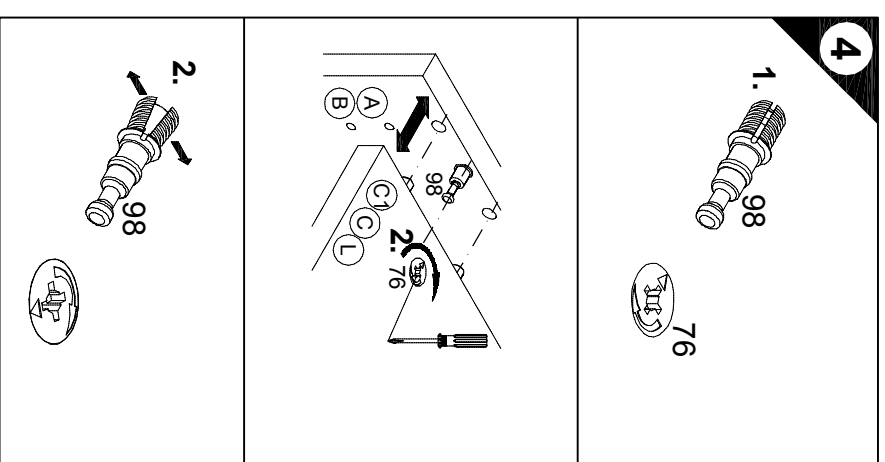
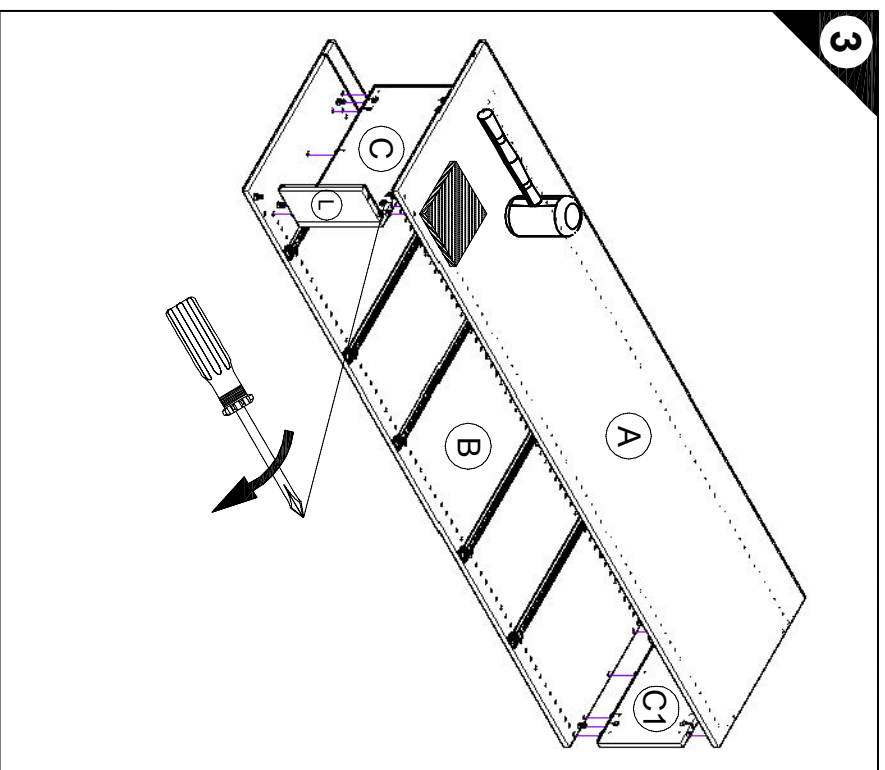
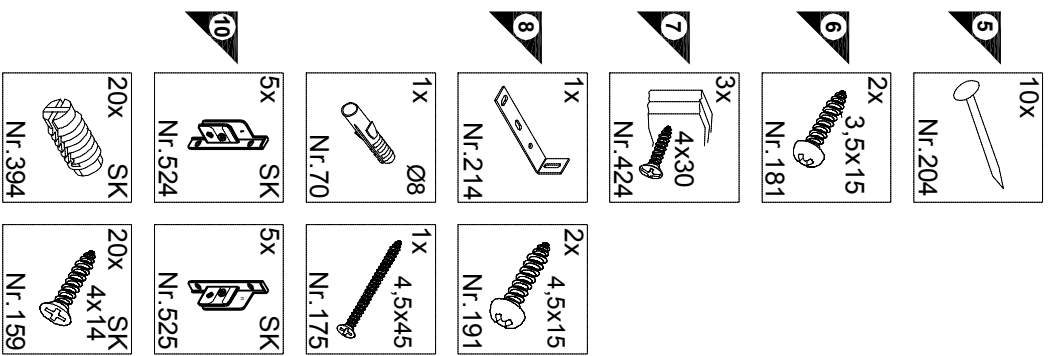

9 Holzunterlage verwenden!
Front andrücken, scharfen Bohrer verwenden und mit wenig Druck durchbohren!
Use a wooden base!
Press front down, use sharp drill bit and, by applying slight pressure, drill a hole
Utiliser un support en bois !
Appuyer sur la façade, utiliser un foret bien affûté et percer en appliquant une faible pression !
Houten onderlegger gebruiken!
Druk het front aan, gebruik een scherpe boor en oefen bij het boren weinig druk uit!
!Utilizar una base de madera!
!Presionar el frente, utilizar una broca afilada y taladrar con poca presión!
Utilizzare una base di legno! Appoggiare la facciata, utilizzare una punta di tarano affilata e trapanare esercitando solo una leggera pressione!
Использовать деревянную подложку!
Прижать фасад, использовать острое сверло и проверлить с незначительным давлением!
Używać podkładkę z drewna!
Docisnąć front, użyć ostrego wiertła i przewiercić, używając małej siły nacisku!

H Alkalmazzon fa alátételt!
Nyomja le az előlapot, használjon éles fűrőt, és kis nyomással fúrja át!
CZ Použitje dřevěný podklad!
Přitlačte čelo, použijte ostrý vrták a prověřte pomocí malého tlaku!
SLO Uporabite leseno podlagol!
Pritisnite ilonico ter z ostrim svedom in z majhnim pritiskom izvijtajte luknjol!
FIN Käytä puualustaa!
Paina etulevy paikalleen, käytä terävää poranterää ja polaa reikä vain kevyesti painamalla!
S Använd ett träunderlag!
Tryck fronten mot underlaget, använd vass borr och borra igenom med ett lätt tryck!
SK Použitie drevený podklad!
Pritlačte front, použijte ostrý vrták a prevěřajte miernym tlakom!
RO suport de lemn!
Impingeați frontul, utilizați un burghiu ascuțit și perforați exercitând doar o presiune redusă!
TR Ahşap taban kullanımı!
Önden bastırın, keskin matkap ucu kullanın ve az basınç uygulayarak delini

